

vehicle : C4 PICASSO	driving assistance	OPR : 99999	
domain		function	parking assistance
component			

principle

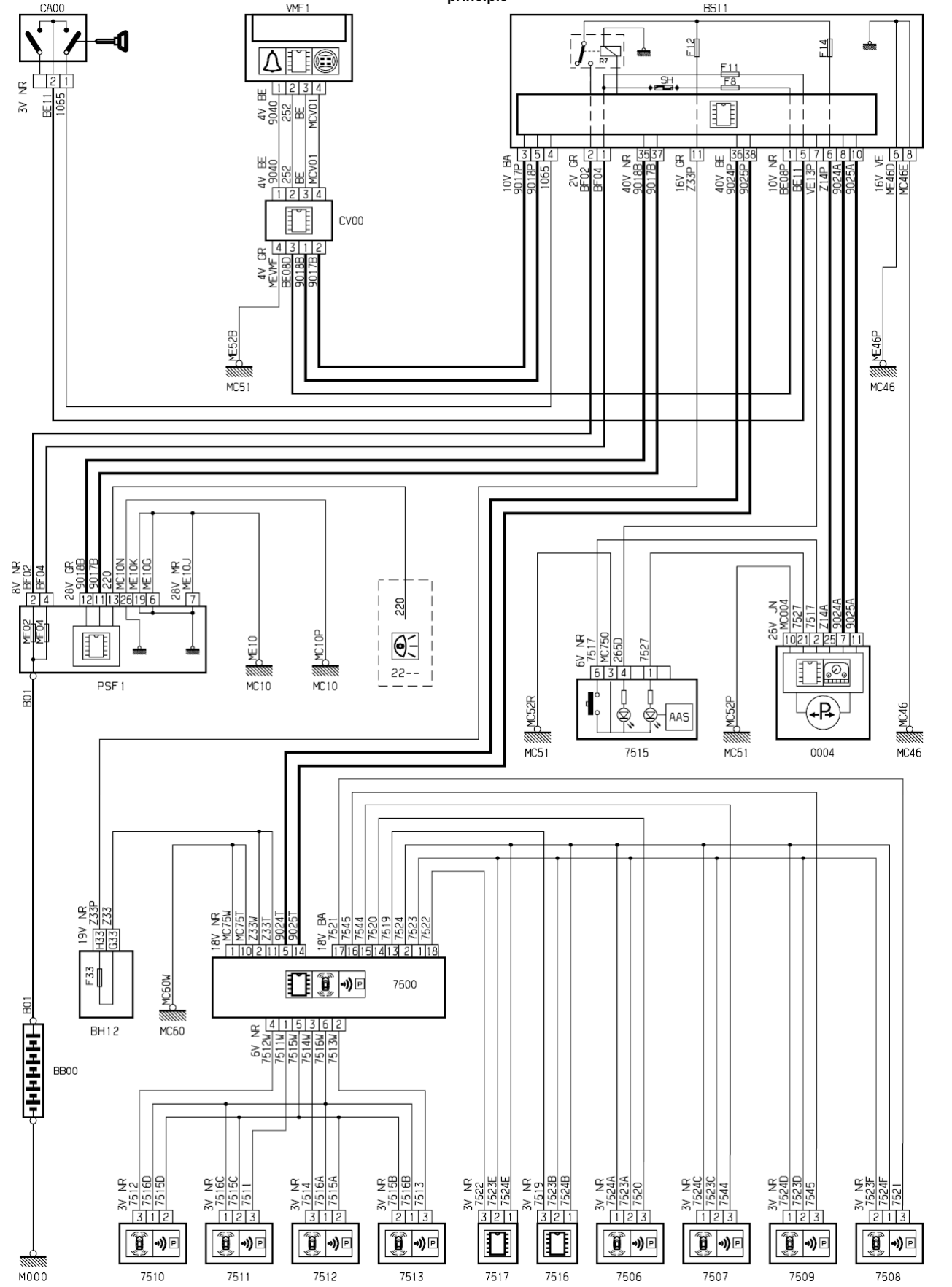

D3ARTL IR

principle

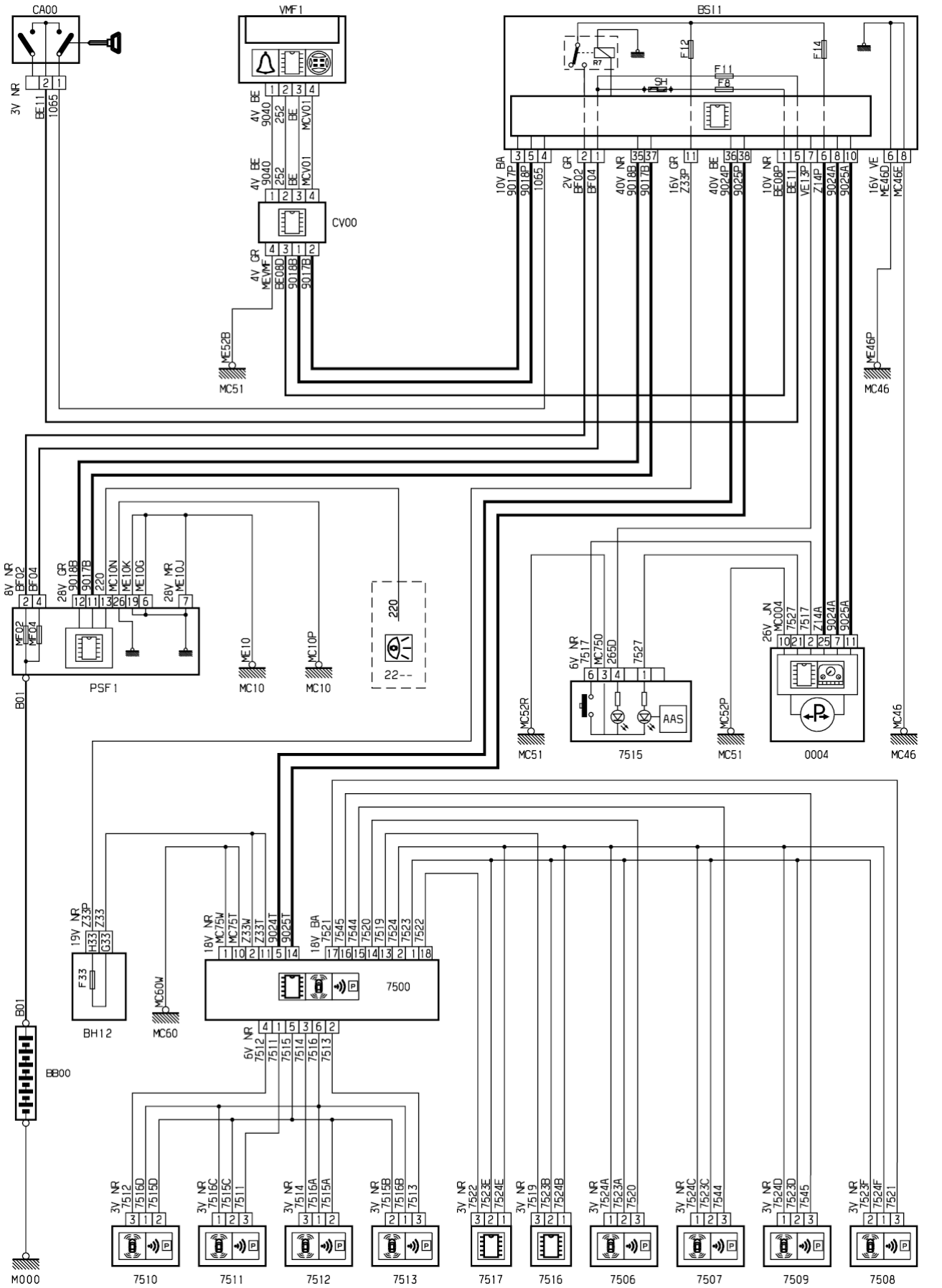

D3ARTLHR

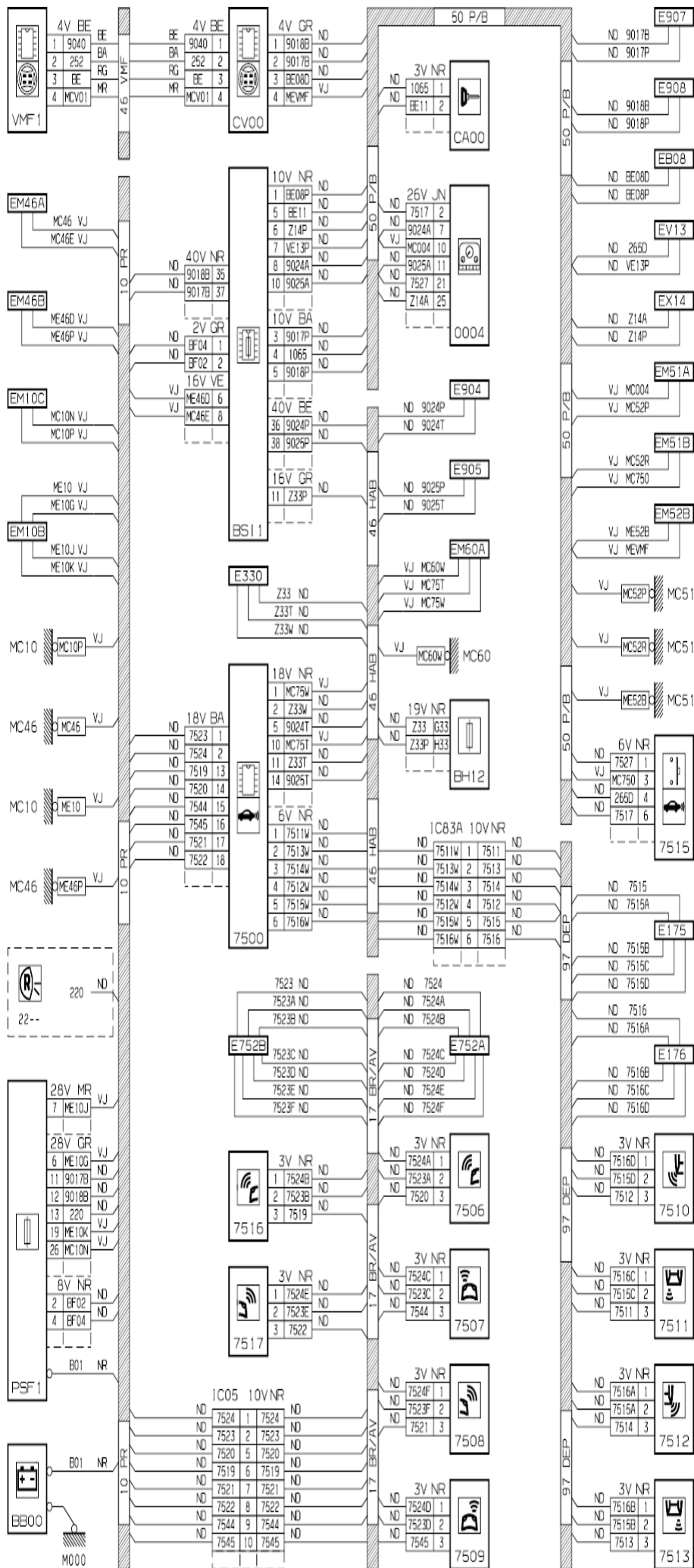

D3ARTL1G

null

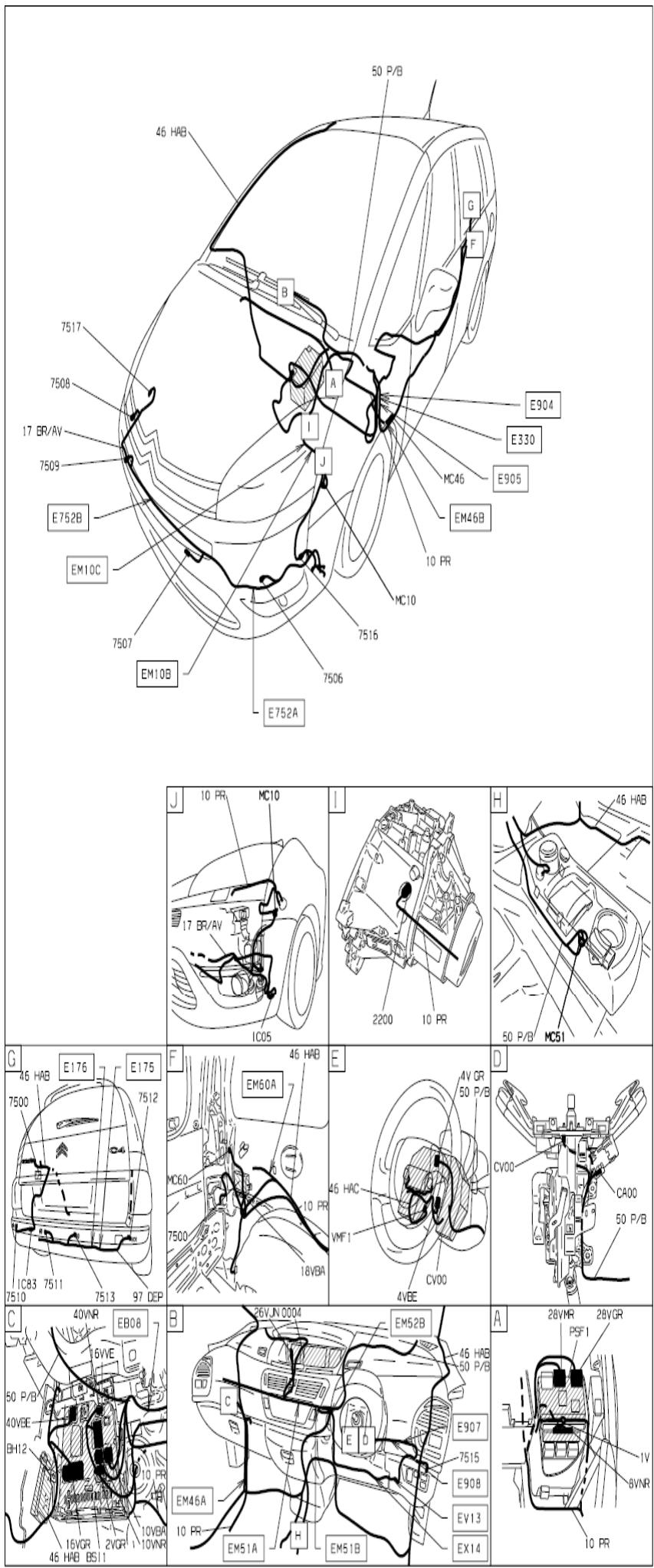

D3ARTLHI

