

GENERAL INFORMATION

The new CVT has been developed to achieve excellent fuel economy, further easy driving, and fun to drive. This CVT has been achieved a quick and smooth acceleration feel suitable for OUTLANDER, when the vehicle accelerates from any speeds. The CVT combines "torque converter" and "continuously variable transmission mechanism by steel belt & pulley" to achieve "high driving performance" and "better fuel economy." Depending on the driving conditions, the comfortable gear ratio is automatically and continuously selected from low to overdrive, ensuring driver-intended smooth driving without shift shocks due to acceleration pedal operation.

SPECIFICATIONS

Transmission model		W1CJA
Torque converter	Model	3-element, 1-stage, 2-phase
	Stall torque ratio	1.83
	Lock-up	Present
Transmission type		Forward automatic CVT (steel belt-driven), reverse 1 speed
Gear ratio	Forward	2.349 - 0.394
	Reverse	1.750
Shift position		P-R-N-D +6-speed sport mode (with the paddle shift)
Final reduction gear ratio		6.466
Control type		Electronically-controlled
Function	Shift control	Present
	Line pressure control	Present
	Select control	Present
	Lock-up control	Present
	Self-diagnosis function	Present
	Fail-safe function	Present
Number of speedometer gears (drive/driven)		- (detected by the ABS sensor)
Oil pump	Model	Vane-type pump
	Drive type	Driven by the engine, sprocket, and chain

CVT fluid	Brand name	DIA QUEEN CVTF-J1
	Capacity (L)	Approximately 7.8

SYSTEM CONFIGURATION

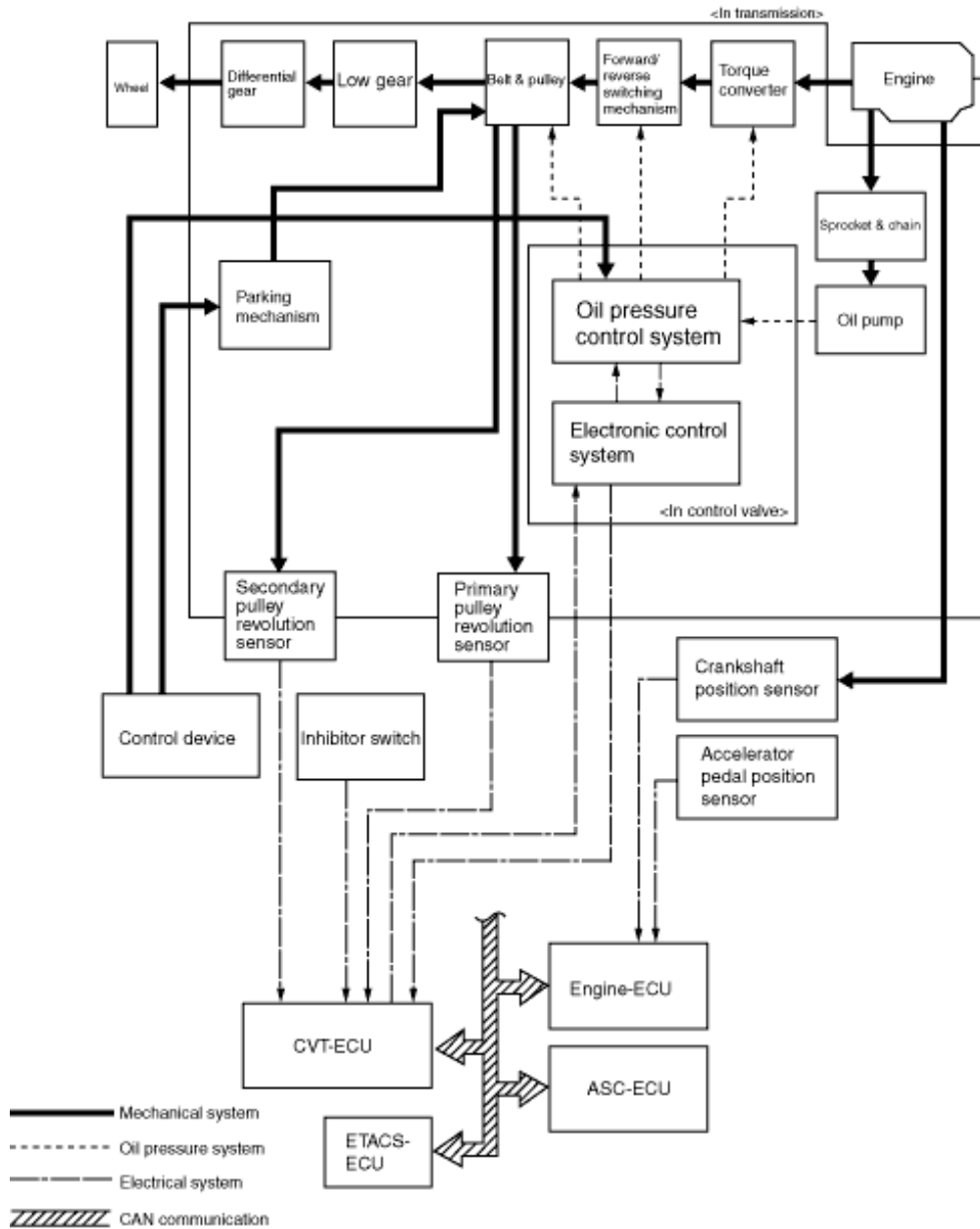

OVERVIEW

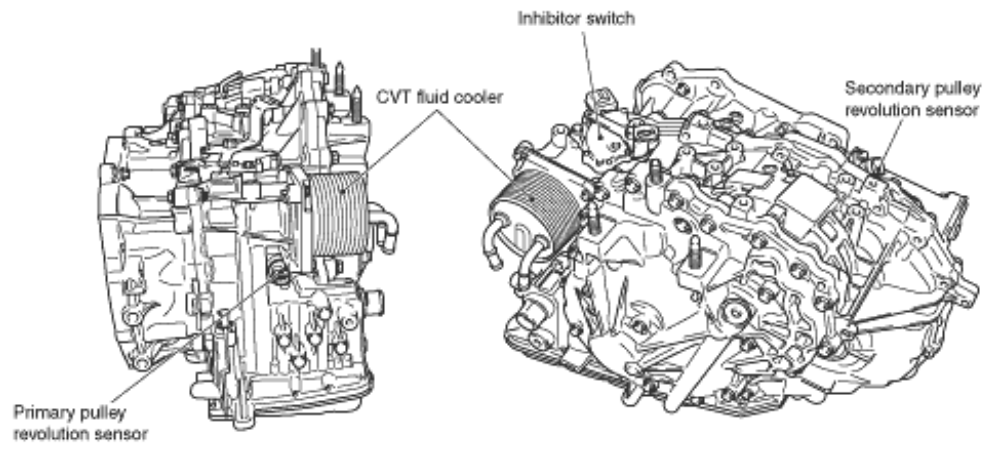

AC507426 AB