

автомобиль : C-CROSSER		OPR : 12153	
область	освещение - сигнализация	функция	корректоры положения фар по высоте
составные части			

принцип

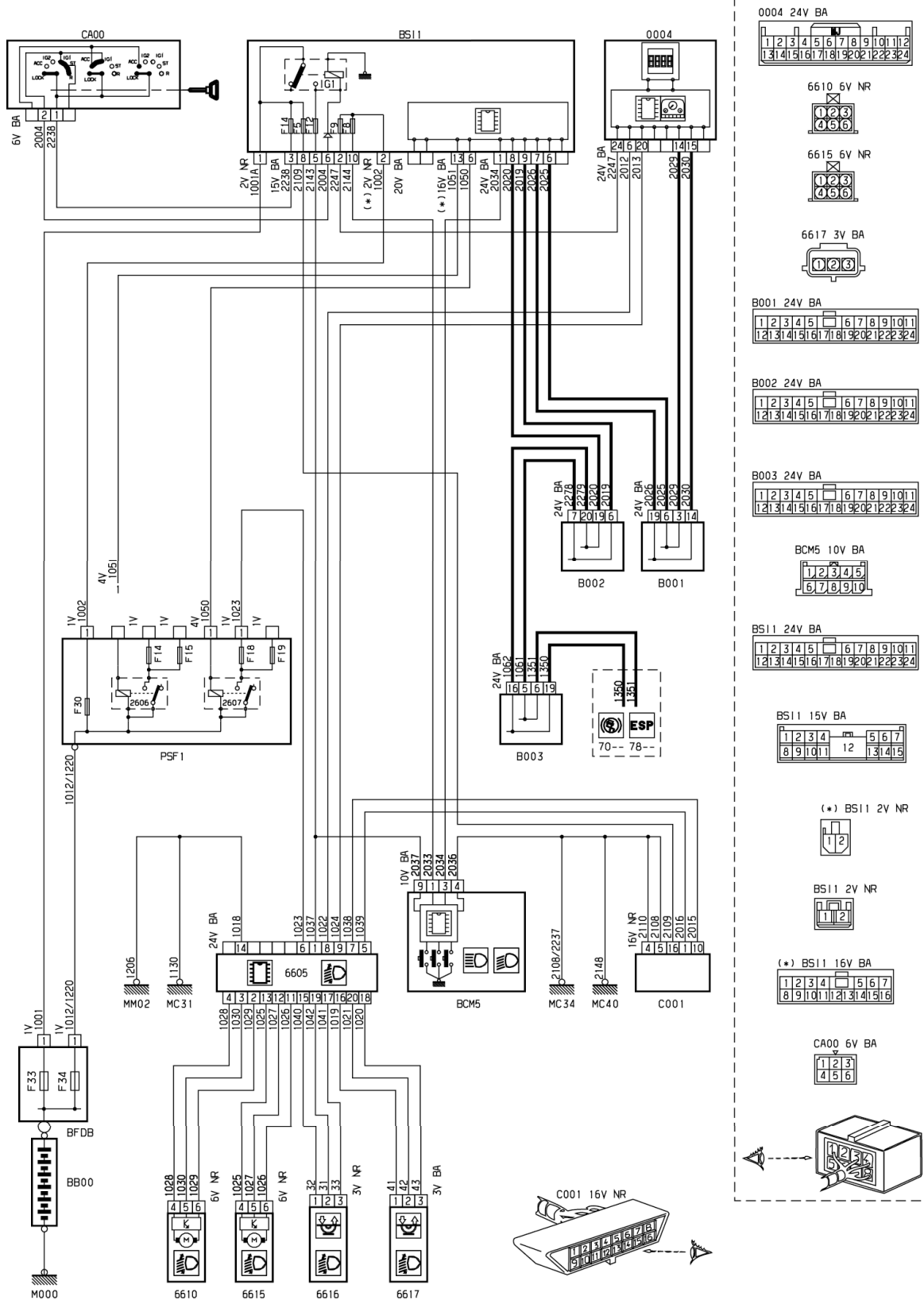

D3ART73R

собственность PSA Peugeot Citroen

19/01/2011

автомобиль : C-CROSSER		OPR : 12153	
область	освещение - сигнализация	функция	корректоры положения фар по высоте
составные части			

прокладка трубопроводов (кабелей, тросов)

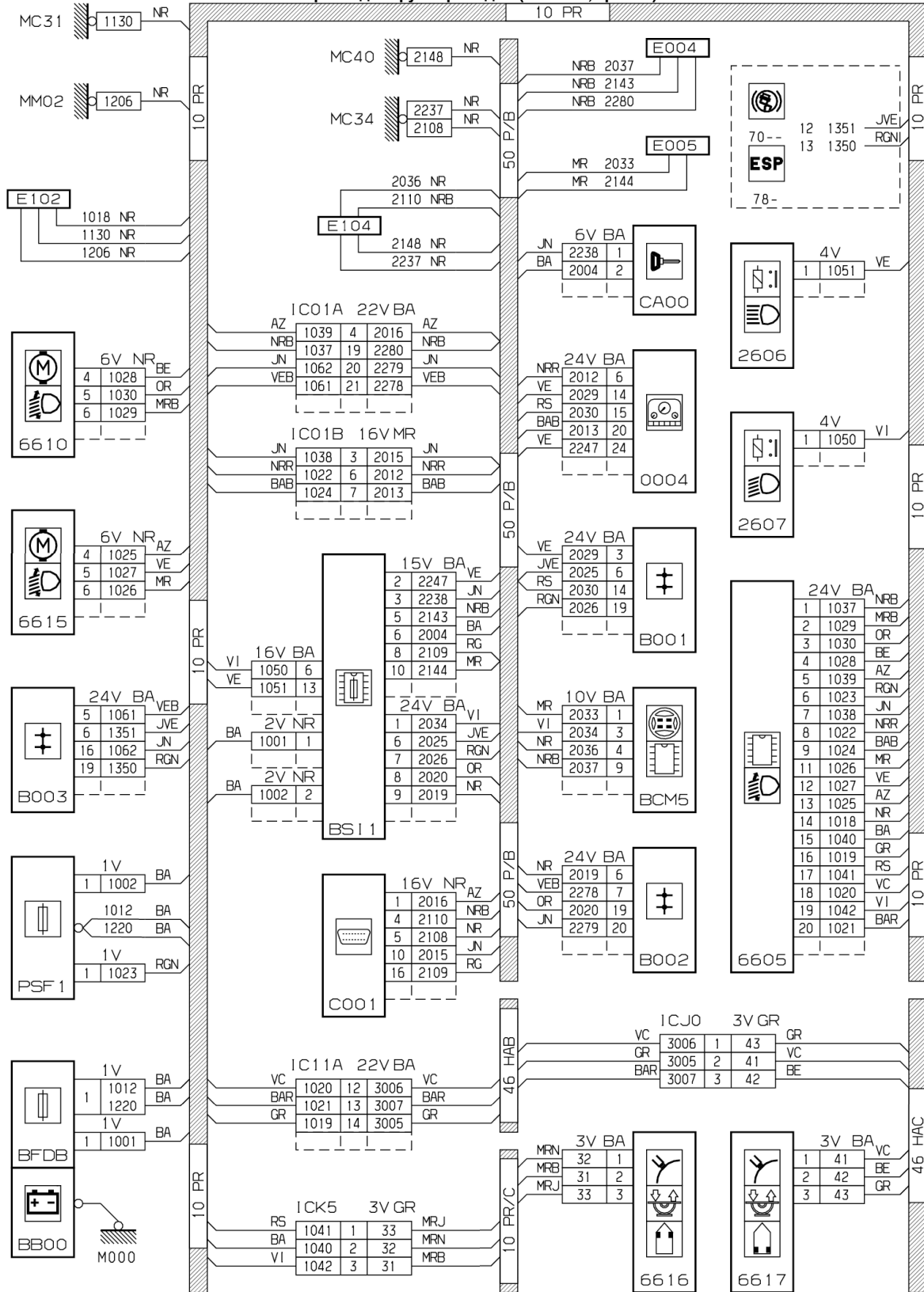

D3ART73G

собственность PSA Peugeot Citroen

19/01/2011

автомобиль : C-CROSSER		OPR : 12153	
область	освещение - сигнализация	функция	фары ближнего света / фары дальнего света
составные части			

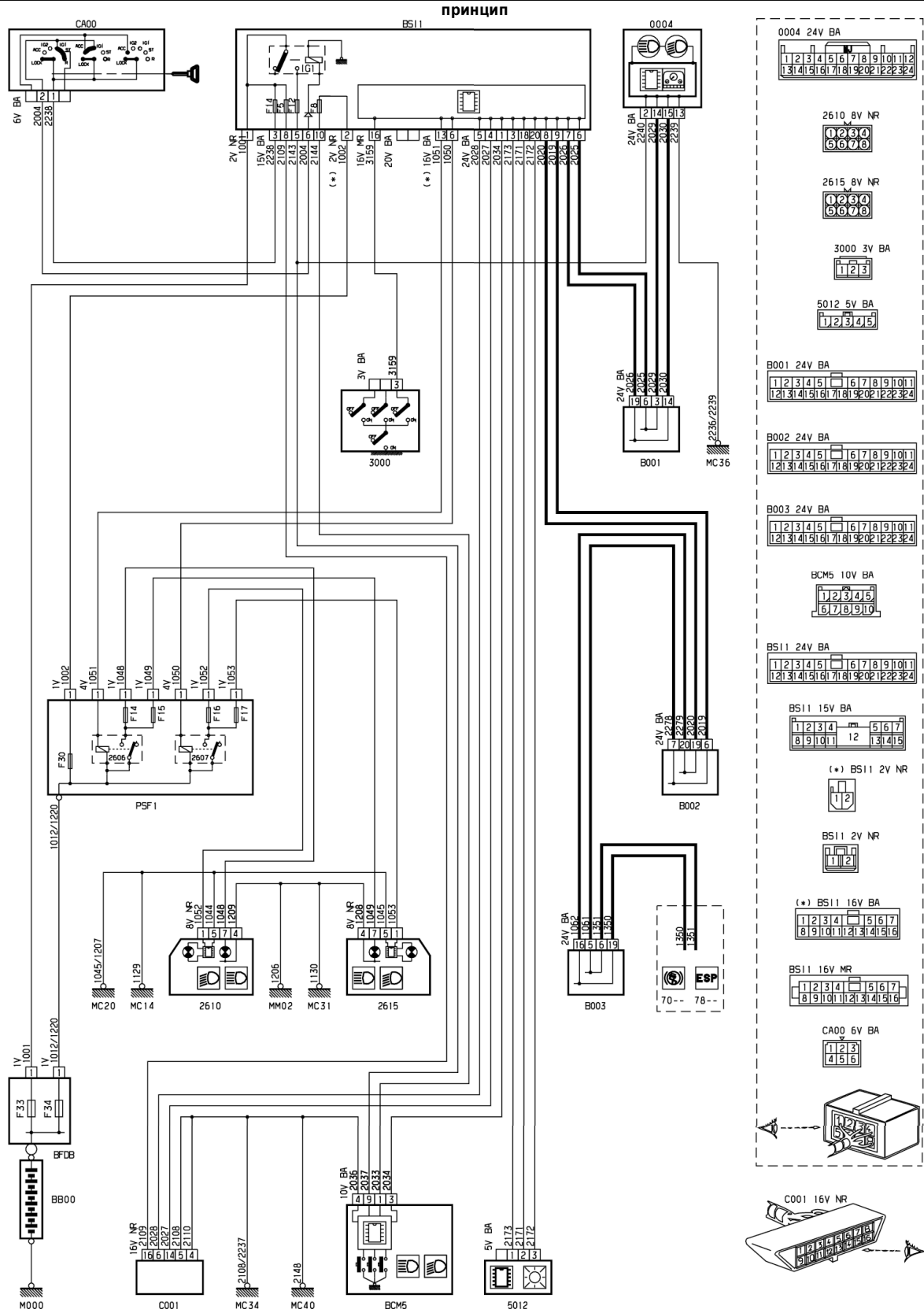

собственность PSA Peugeot Citroen

D3ART6ER

19/01/2011

автомобиль : C-CROSSER		OPR : 12153	
область	освещение - сигнализация	функция	фары ближнего света / фары дальнего света
составные части			

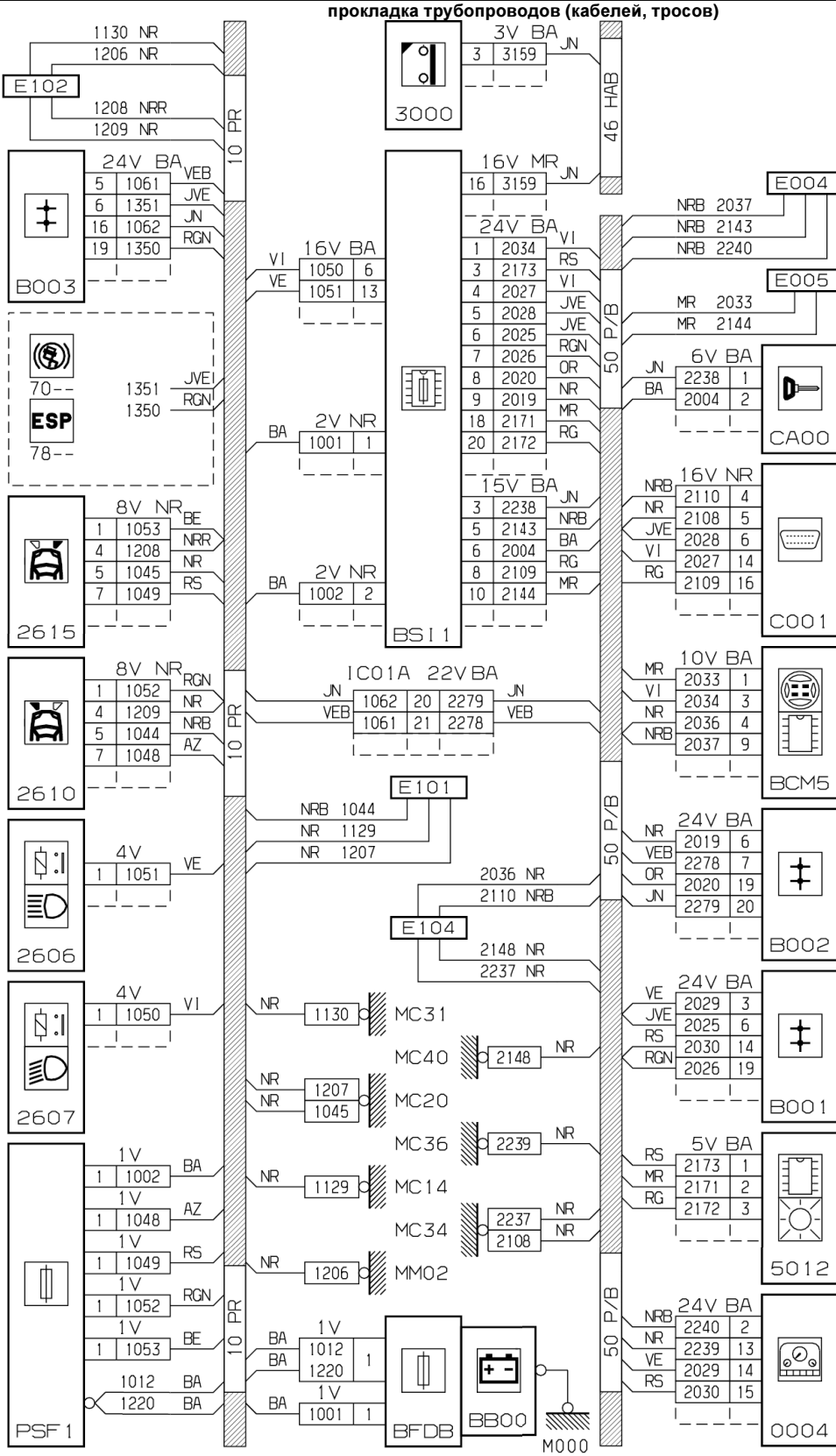

D3ART6EG

собственность PSA Peugeot Citroen

19/01/2011

автомобиль : C-CROSSER		OPR : 12153	
область	Общие сведения (характеристики)	функция	распределение внутренних соединений
составные части			
D3BQ43P0	ВНУТРЕННИЕ СОЕДИНЕНИЯ		

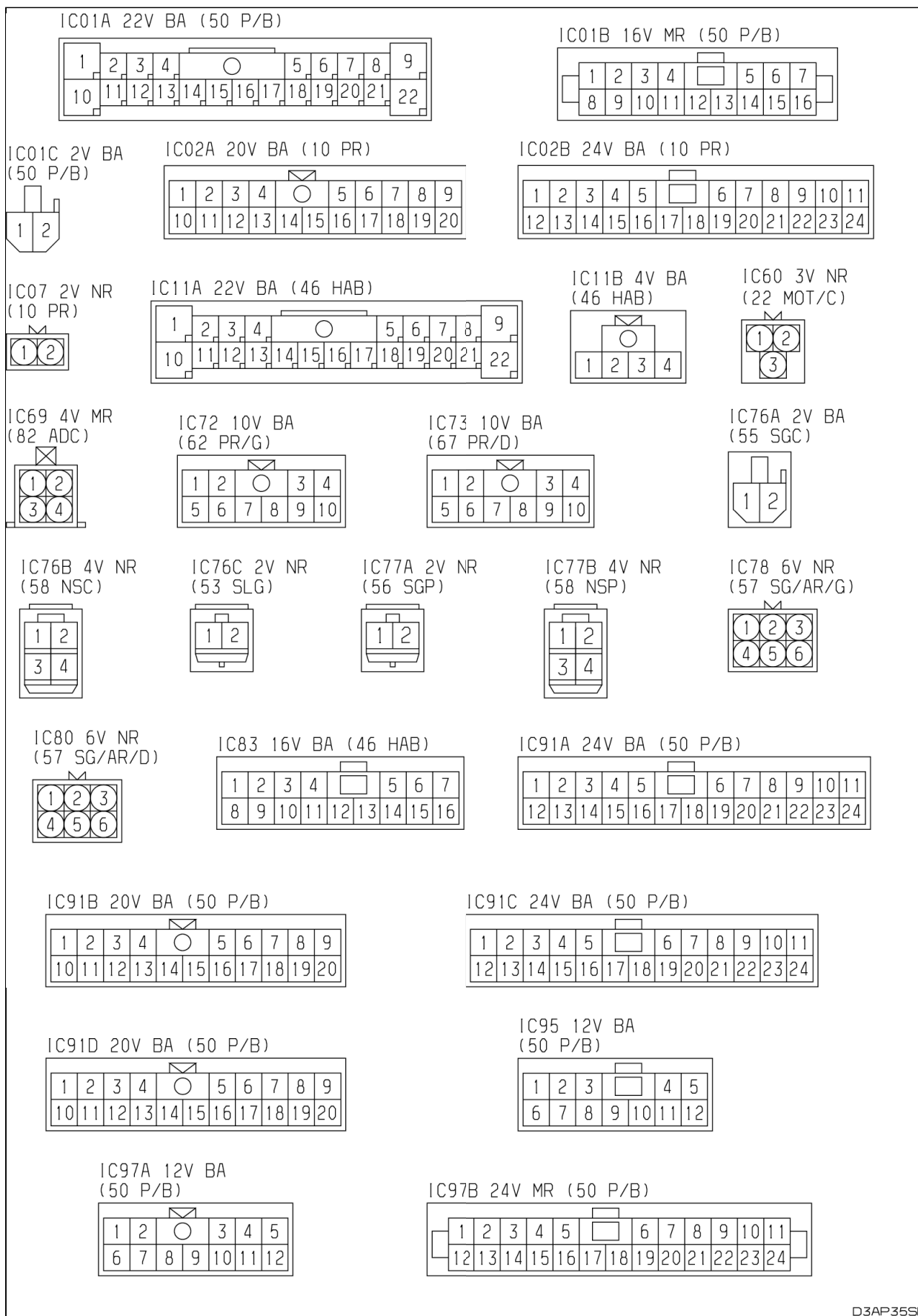

D3AP35SP

Рис. d3ap35sp



Рис. d3ap35tp

собственность PSA Peugeot Citroen

19/01/2011

автомобиль : C-CROSSER		OPR : 12153	
область	Общие сведения (характеристики)		функция детали разъемов
составные части			
D3BQ2TP0	РАЗЪЕМЫ		

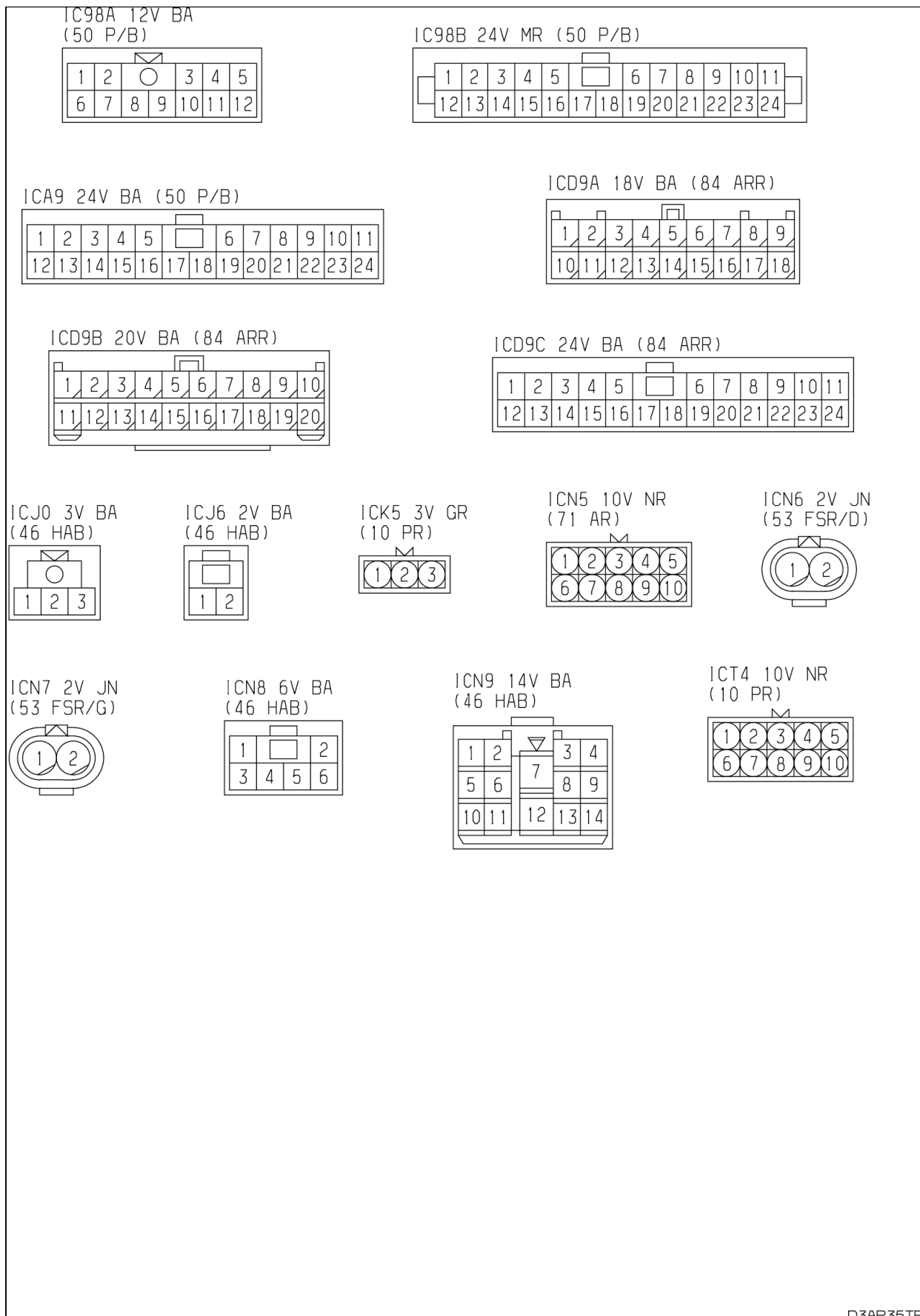
0004 24V BA

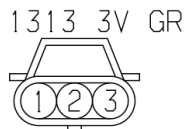
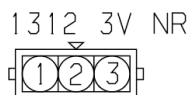
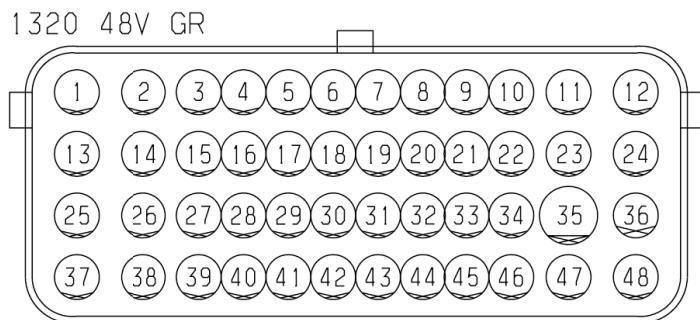
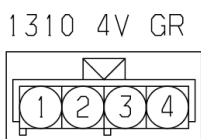
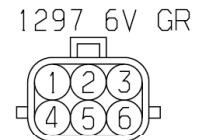
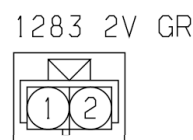
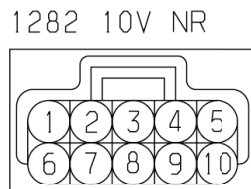
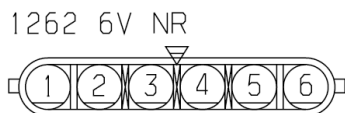
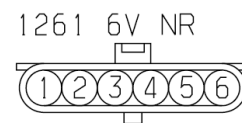
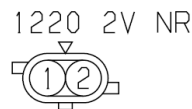
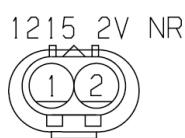
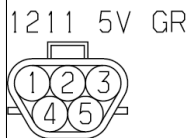
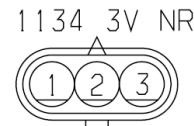
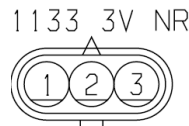
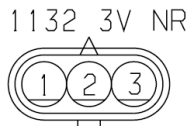
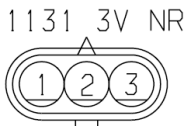
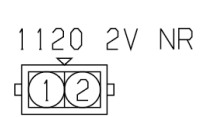
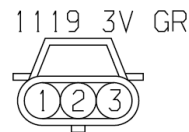
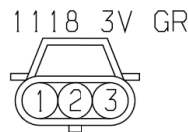
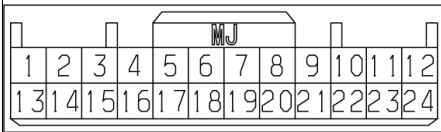

1320 64V GR

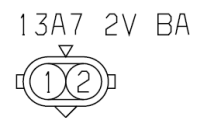
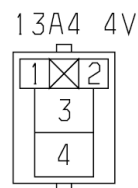
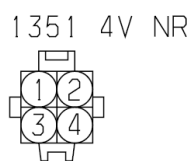
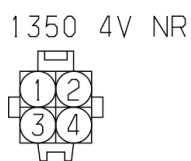
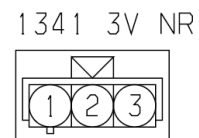
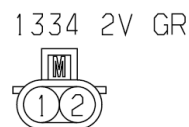
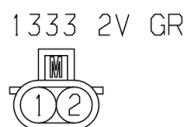
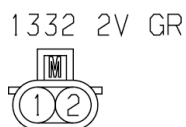
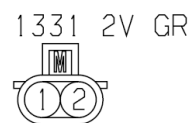
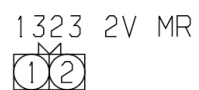
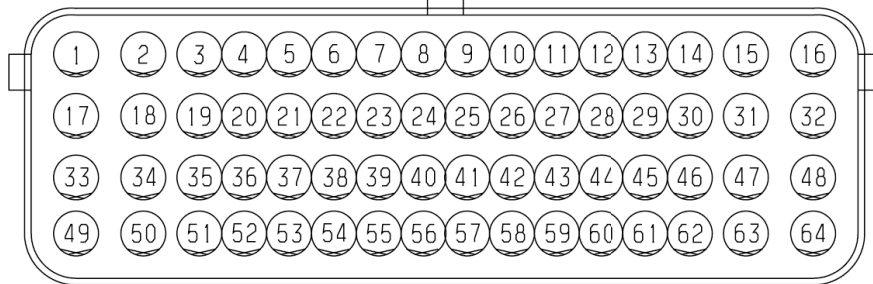

D3AP35DP

Рис. d3ap35dp

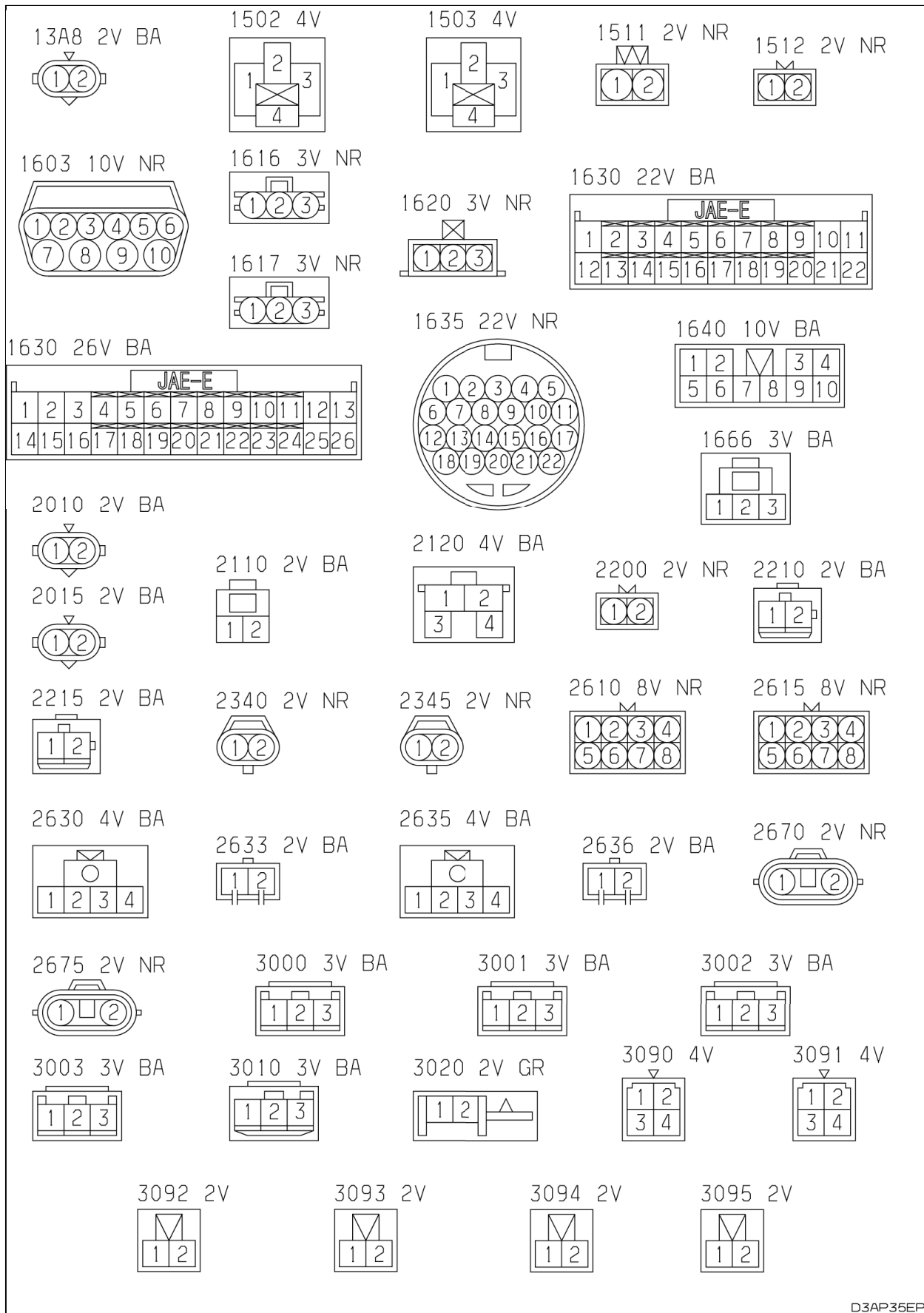

D3AP35EP

Рис. d3ap35ep

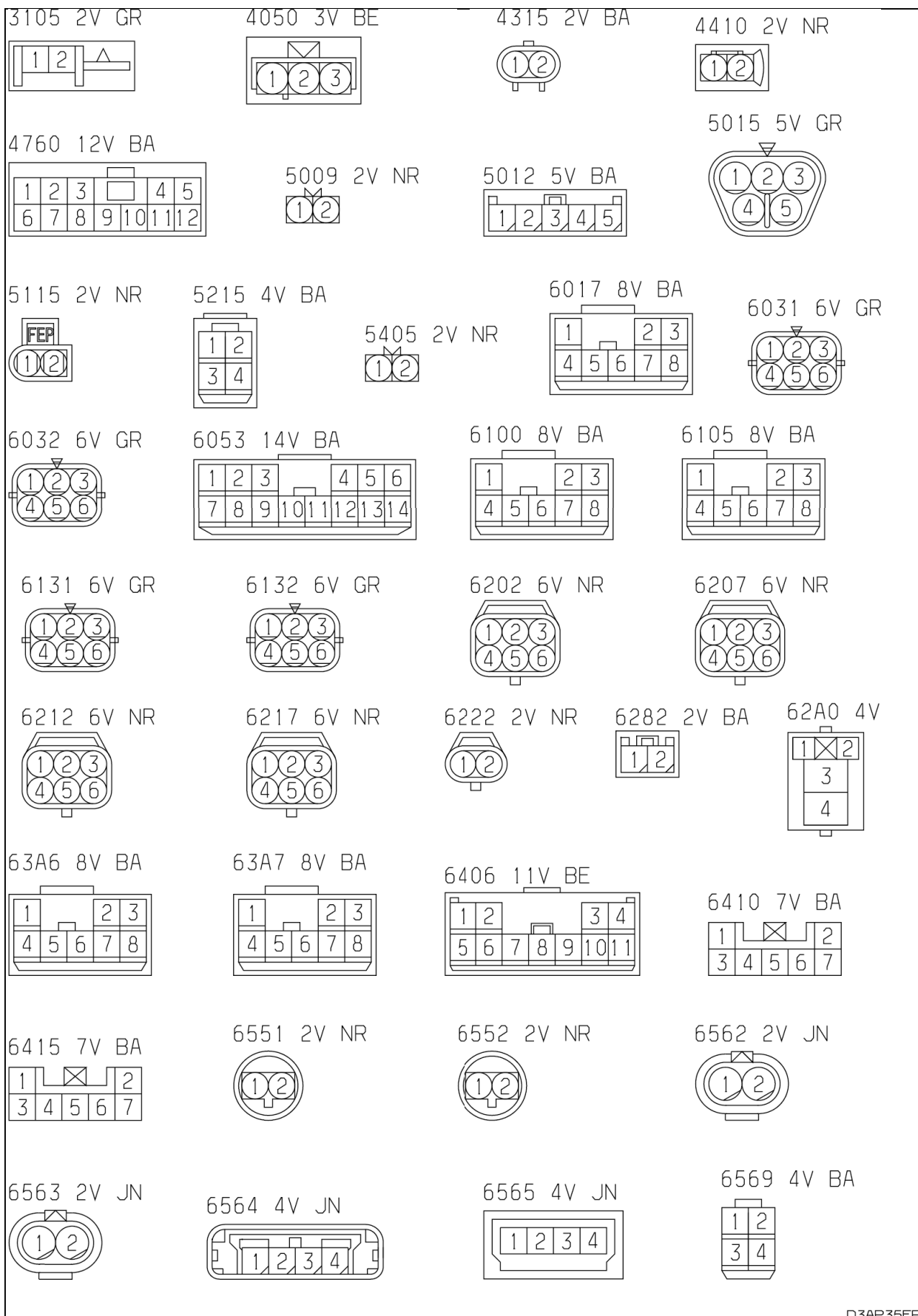

D3AP35FP

Рис. d3ap35fp

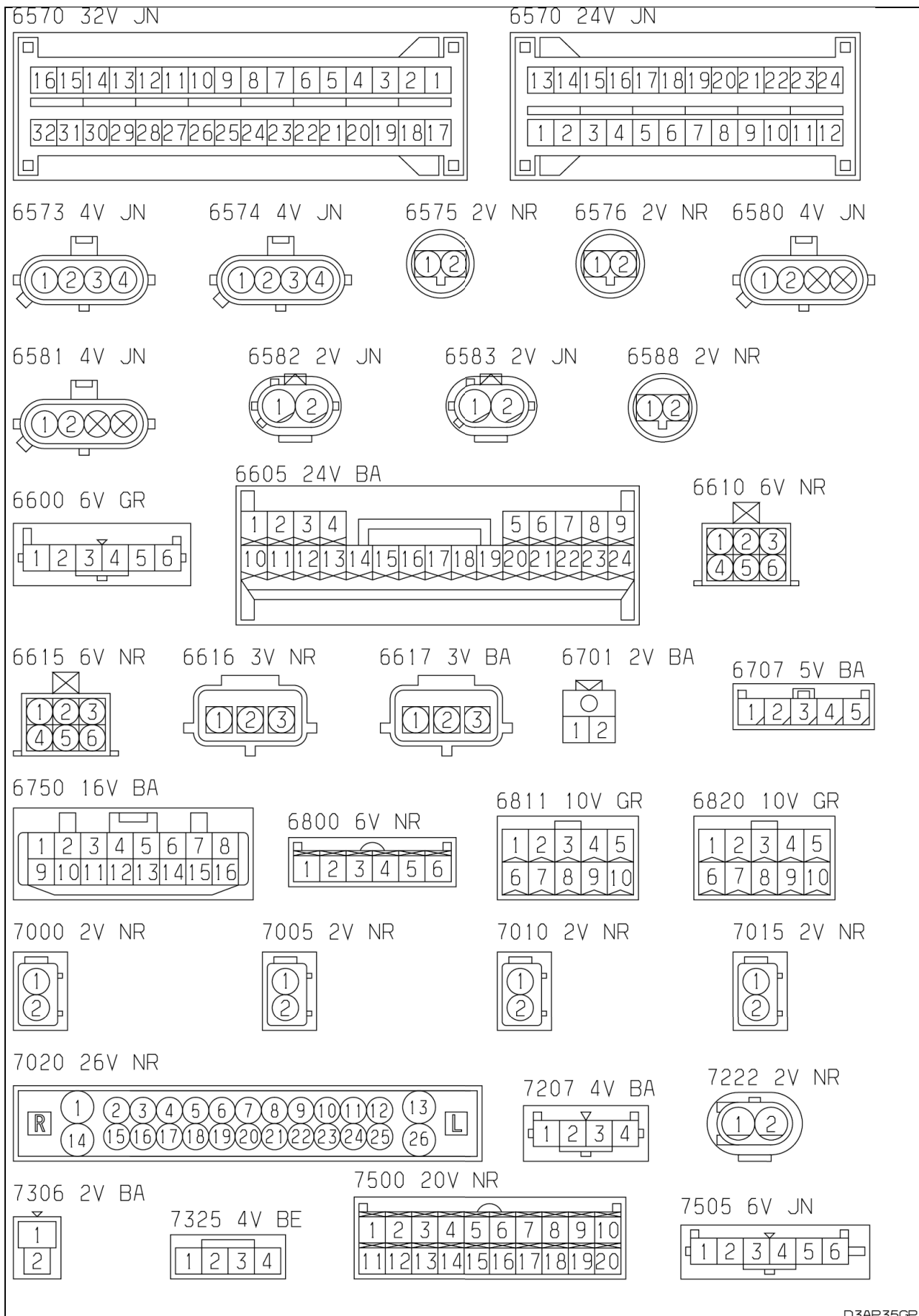

D3AP35GP

Рис. d3ap35gp

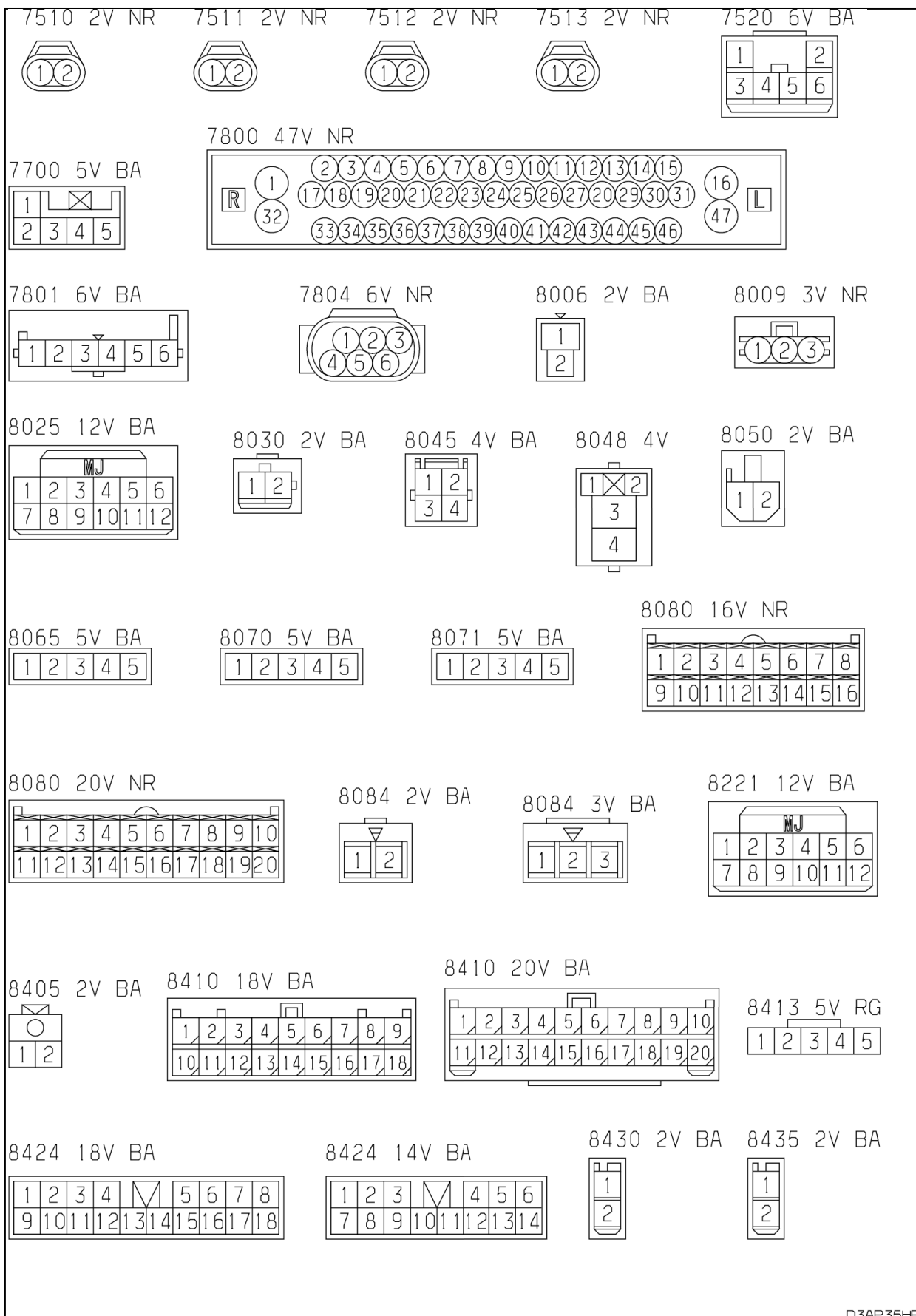

D3AP35HP

Рис. d3ap35hp

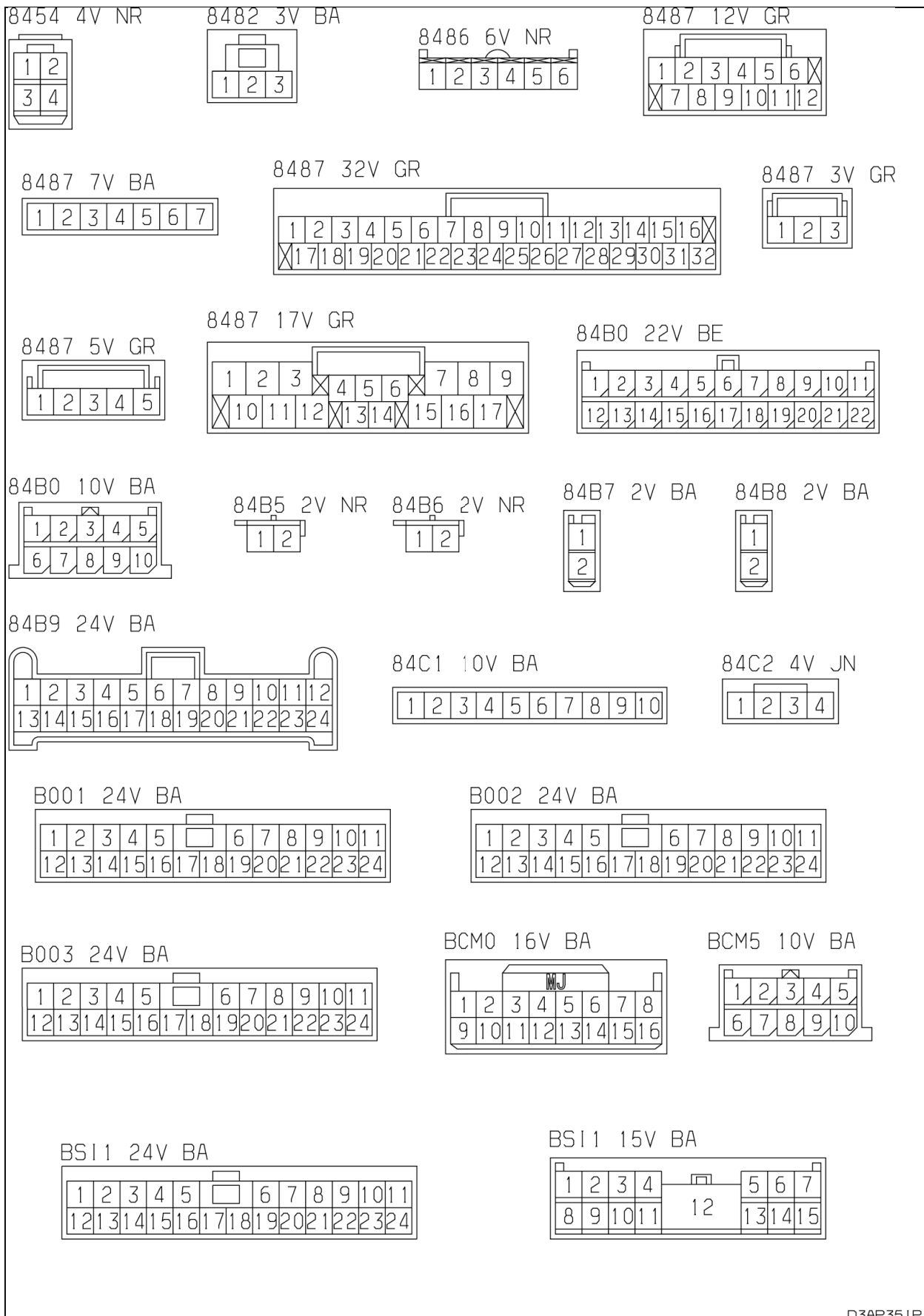

D3AP35IP

Рис. d3ap35ip

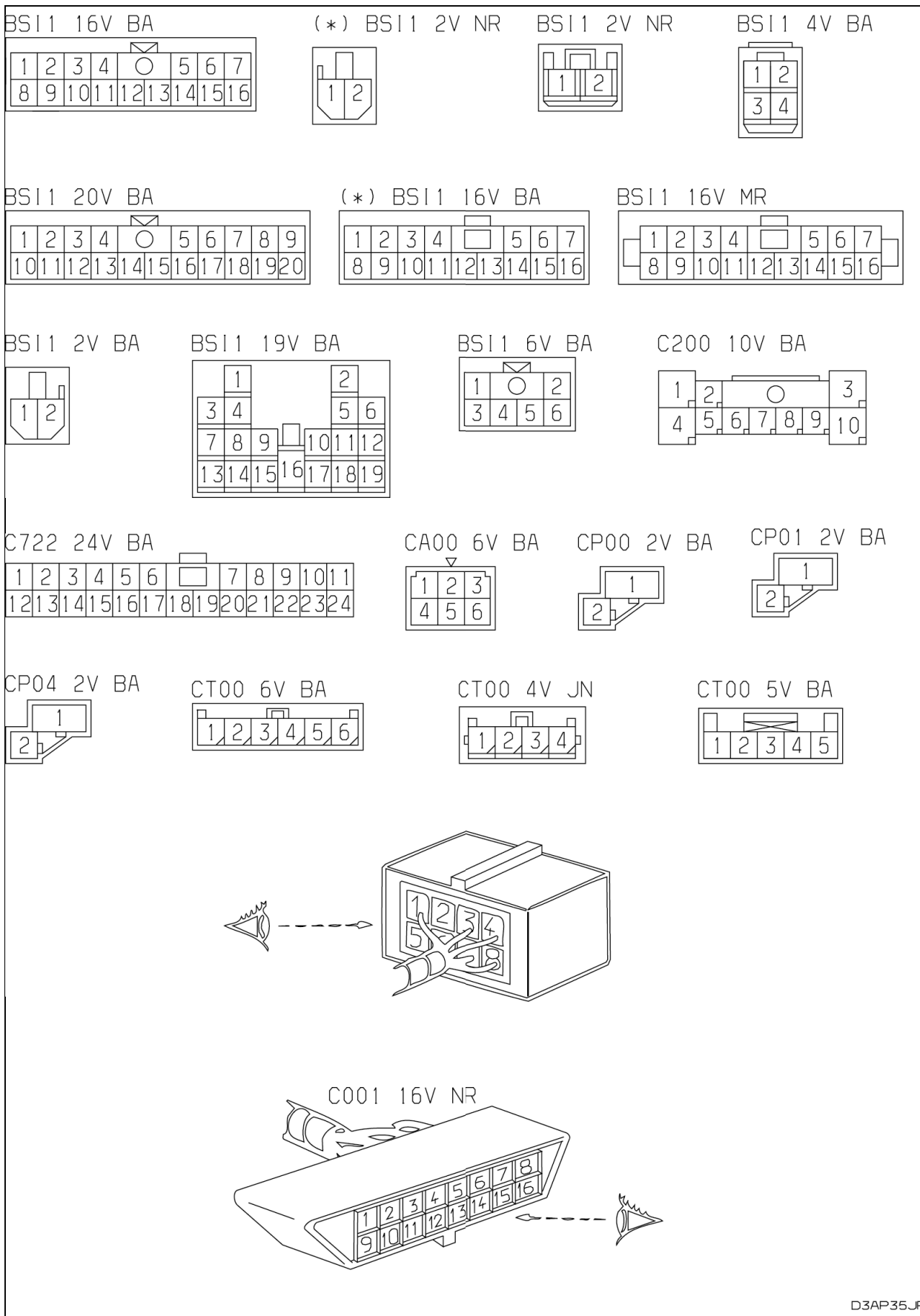

D3AP35JP

Рис. d3ap35jp

собственность PSA Peugeot Citroen

19/01/2011