

## Low-Noise AM/FM Antenna Impedance Matching IC

### Description

The U4254BM is an integrated low-noise AM/FM antenna impedance matching circuit in BICMOS technology. The device is designed in particular for car application and is suitable for windscreen and roof antennas.

### Features

- High dynamic range for AM and FM
- Integrated AGC for FM
- High intercept point 3rd order for FM
- FM amplifier adjustable to various cable impedance
- High intercept point 2nd order for AM
- Low noise output voltage
- Low power consumption

### Block Diagram

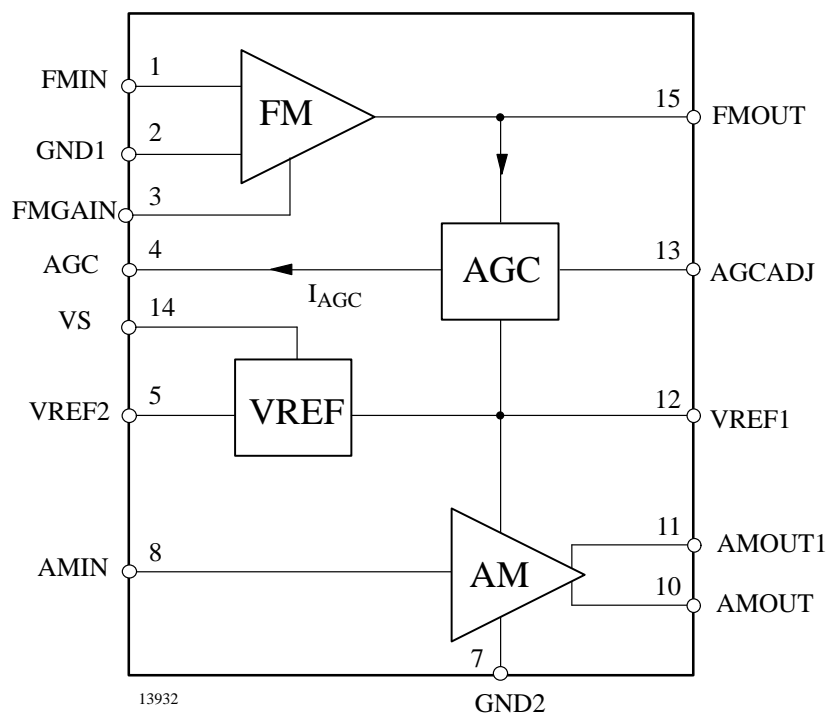
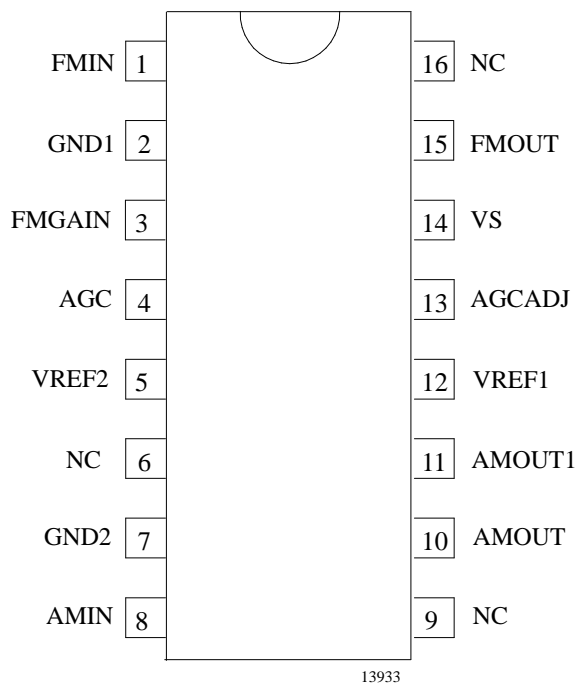

Figure 1. Block diagram

## Ordering and Package Information

Extended Type Number	Package	Remarks
U4254BM-AFP	SO16	
U4254BM-AFPG3	SO16	Taping corresponding, ICE-286-3

## Pin Description



Pin	Symbol	Function
1	FMIN	FM input
2	GND1	Ground for FM part
3	FMGAIN	FM gain adjustment
4	AGC	AGC output
5	VREF2	Reference voltage 2 output
6	NC	Not connected
7	GND2	Ground for AM part
8	AMIN	AM input
9	NC	Not connected
10	AMOUT	AM output
11	AMOUT1	AM output
12	VREF1	Reference voltage 1 output
13	AGCADJ	Adjustment FM wide-band AGC threshold
14	VS	Supply voltage
15	FMOUT	FM output
16	NC	Not connected

Figure 2. Pinning

**Pin Description**

**FMIN**

FMIN is the input of the FM amplifier. It is the base of a bipolar transistor. A resistor or a coil is connected between FMIN and VREF2. If a coil is used, noise performance is excellent.

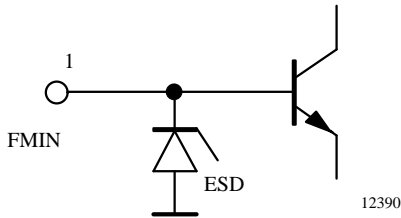

Figure 3.

**GND1**

To avoid crosstalk between AM and FM signals, the circuit has two separate ground pins. GND1 is the ground for the FM part.

**FMGAIN**

The DC current of the FM amplifier transistor is adjusted by an external resistor which is connected between FMGAIN and GND1. In order to influence the AC gain of the amplifier, a resistor is connected in series to a capacitor between FMGAIN and GND1. The capacitor has to be a short at frequencies of 100 MHz.

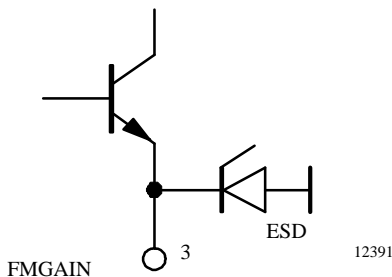

Figure 4.

**AGC**

DC current flows into the AGC pin at high FM antenna input signals. This current has to be amplified via the current gain of an external PNP transistor that feeds a PIN-diode. This diode dampens the antenna input signal and protects the amplifier input against overload. The maximum current which flows in the AGC pin is approximately 1 mA. In low end applications, the AGC function is not necessary and therefore the external components can be omitted.

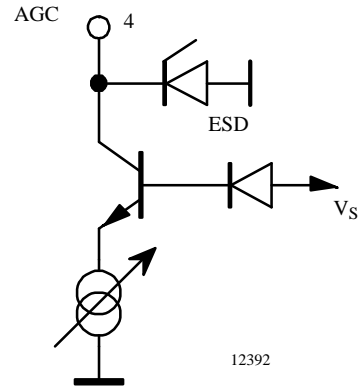

Figure 5.

**AGCADJ**

The threshold of the AGC can be adjusted by varying the DC current at pin AGCADJ. If pin AGCADJ is connected directly to GND1, the threshold is set to 96 dBμV at the FM amplifier output. If a resistor is connected between AGCADJ and GND1, the threshold is shifted to higher values with increasing resistances. If AGCADJ is open, the threshold is set to 106 dBμV.

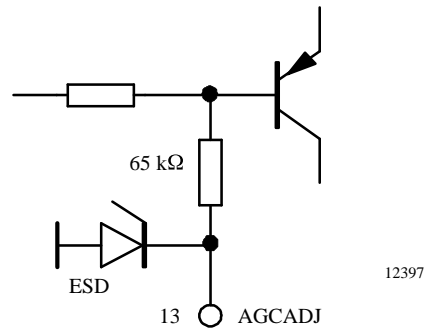

Figure 6.

**FMOUT**

The FM amplifiers output is an open collector of a bipolar RF-transistor. It should be connected to VS via a coil.

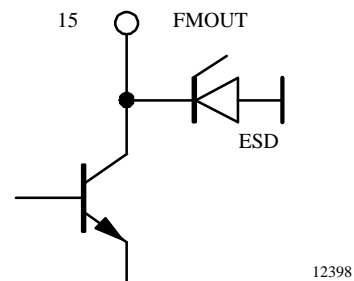

Figure 7.

## AMIN

The AM input has an internal bias voltage. The DC voltage at this pin is  $V_{REF1}/2$ . The input resistance is about 470 k $\Omega$ . The input capacitance is less than 10 pF.

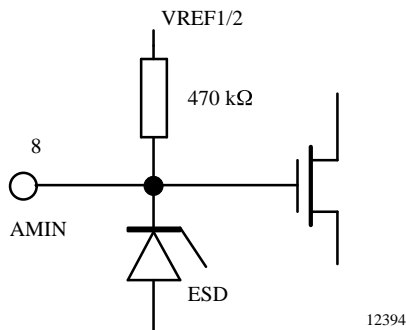

Figure 8.

## AMOUT, AMOUT1

The buffered AM amplifier consists of a complementary pair of CMOS source followers. The transistor gates are connected to AMIN. The pin AMOUT is the NMOS transistor's source, pin AMOUT1 is the PMOS transistor's source. Due to the two different DC levels of these pins, they have to be connected together via an external capacitor of about 100 nF. By means of this technique an excellent dynamic range can be achieved.

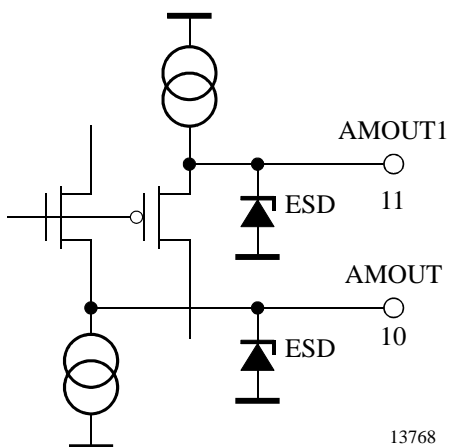

Figure 9.

## VREF1

VREF1 is the stabilized voltage for the AM amplifier and the AGC block. To achieve excellent noise performance at LW frequencies, it is recommended that this pin is connected to ground via an external capacitor of about 1  $\mu$ F.

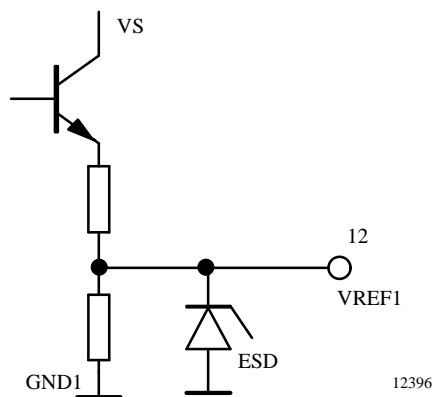

Figure 10.

## VREF2

For the DC biasing of the FM amplifier a second voltage reference circuit is integrated. Because of temperature independence of the collector current the output voltage has a negative temperature coefficient of about  $-1$  mV/K. To stabilize this voltage an external capacitor to ground of a few nF is recommended.

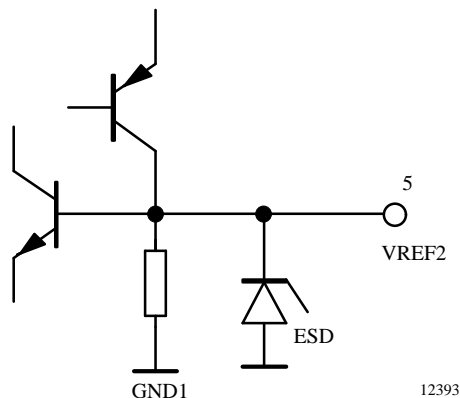

Figure 11.

## GND2

GND2 is the ground for the AM amplifier.

## Functional Description

The U4254BM is an integrated AM/FM antenna impedance matching circuit. It compensates cable losses between the antenna (for example windscreen, roof or bumper antennas) and the car radio which is usually placed far away from the antenna.

The FM amplifier provides excellent noise performance. External components are used to adjust the gain and the input-output matching impedance. Therefore it is possible to adjust the amplifier to various cable impedances (usually 50, 75 or 150  $\Omega$ ). To protect the amplifier against input overload an Automatic Gain Control (AGC) is included on the chip. The AGC

observes the AC voltage at the FM amplifier output, rectifies this signal, and delivers DC current to dampen the input antenna signal via an external PIN diode. The threshold for the AGC is adjustable. Simple and temperature compensated biasing is possible due to the integrated voltage reference  $V_{Ref2}$ .

The AM part consists of a buffer amplifier. The voltage gain of this stage is approximately one. The input resistance is 470 k $\Omega$ , the input capacitance less than 10 pF. The output resistance is 125  $\Omega$ . An excellent dynamic range is achieved due to the complementary CMOS source follower stage.

## Absolute Maximum Ratings

Reference point is ground (Pins 2 and 7)

Parameters	Symbol	Value	Unit
Supply voltage	$V_S$	8.8	V
Power dissipation, $P_{tot}$ at $T_{amb} = 85^\circ\text{C}$	$P_{tot}$	460	mW
Junction temperature	$T_j$	150	$^\circ\text{C}$
Ambient temperature	$T_{amb}$	-40 to +85	$^\circ\text{C}$
Storage temperature	$T_{stg}$	-50 to +150	$^\circ\text{C}$
Electrostatic handling (HBM)	$\pm V_{ESD}$	2000	V

## Thermal Resistance

Parameters	Symbol	Value	Unit
Junction ambient	$R_{thJA}$	140	K/W

## Electrical Characteristics

See test circuit

$V_S = 8\text{ V}$ ,  $T_{\text{amb}} = 25^\circ\text{C}$ , unless otherwise specified

Parameters	Test Conditions / Pins	Symbol	Min.	Typ.	Max.	Unit
Supply voltage	Pin 14	$V_S$	7.2	8	8.8	V
Supply currents	Pin 14	$I_S$		4		mA
Reference voltage 1 output ( $I_{12} = 0$ )	Pin 12	$V_{\text{Ref1}}$		5.5		V
Reference voltage 2 output ( $I_5 = 0$ )	Pin 5	$V_{\text{Ref2}}$		2.6		V
Temperature dependence of VREF2	Pin 5	$V_{\text{Ref2}}/\Delta T$		-1		mV/K
<b>AM amplifier</b>						
Input resistance	Pin 8	$R_{\text{AMIN}}$		470		k $\Omega$
Input capacitance	Pin 8	$C_{\text{AMIN}}$			10	pF
Output resistance	Pin 10	$R_{\text{OUT}}$		125		$\Omega$
Voltage gain	Pin 10 / Pin 8	$a$		0.85		
Output noise voltage (rms value)	Pin 10 S1 switched to 2; B = 6 kHz 150 kHz to 300 kHz 500 kHz to 6.5 kHz	$V_{\text{N1}}$ $V_{\text{N2}}$		-2 -6		dB $\mu$ V dB $\mu$ V
2nd harmonic	Pin 10 S2 switched to 1 $f_{\text{AMIN}} = 500\text{ kHz}$ , Output voltage = 110 dB $\mu$ V			-65		dBc
<b>FM amplifier</b>						
Supply current limit	$I_{\text{AGC}}$ , $I_{\text{AGCADJ}} = 0\text{ A}$ , Pin 15	$I_{15}$		33	35	mA
Input resistance	$f = 100\text{ MHz}$ Pin 1	$R_{\text{FMIN}}$		50		$\Omega$
Output resistance	$f = 100\text{ MHz}$ Pin 15	$R_{\text{FMOUT}}$		50		$\Omega$
Power gain	$f = 100\text{ MHz}$ Pin 15/ Pin 1	$G$		5		dB
Output noise voltage	Pin 15 $f = 100\text{ MHz}$ , B = 120 kHz	$V_{\text{N}}$		0		dB $\mu$ V
3rd order output intercept	$f = 100\text{ MHz}$ Pin 15			132		dB $\mu$ V
<b>AGC</b>						
AGC input voltage threshold	$f = 100\text{ MHz}$ Pin 15 S2 switched to 1; AGC threshold DC current is 10 $\mu$ A at Pin 4	$V_{\text{th1}}$		96		dB $\mu$ V
AGC input voltage threshold	$f = 100\text{ MHz}$ Pin 15 S2 switched to 2; AGC threshold DC current is 10 $\mu$ A at Pin 4	$V_{\text{th2}}$		106		dB $\mu$ V
AGC output current	AGC active	$I_{\text{AGC}}$			1.2	mA



## FM Intermodulation Distortion

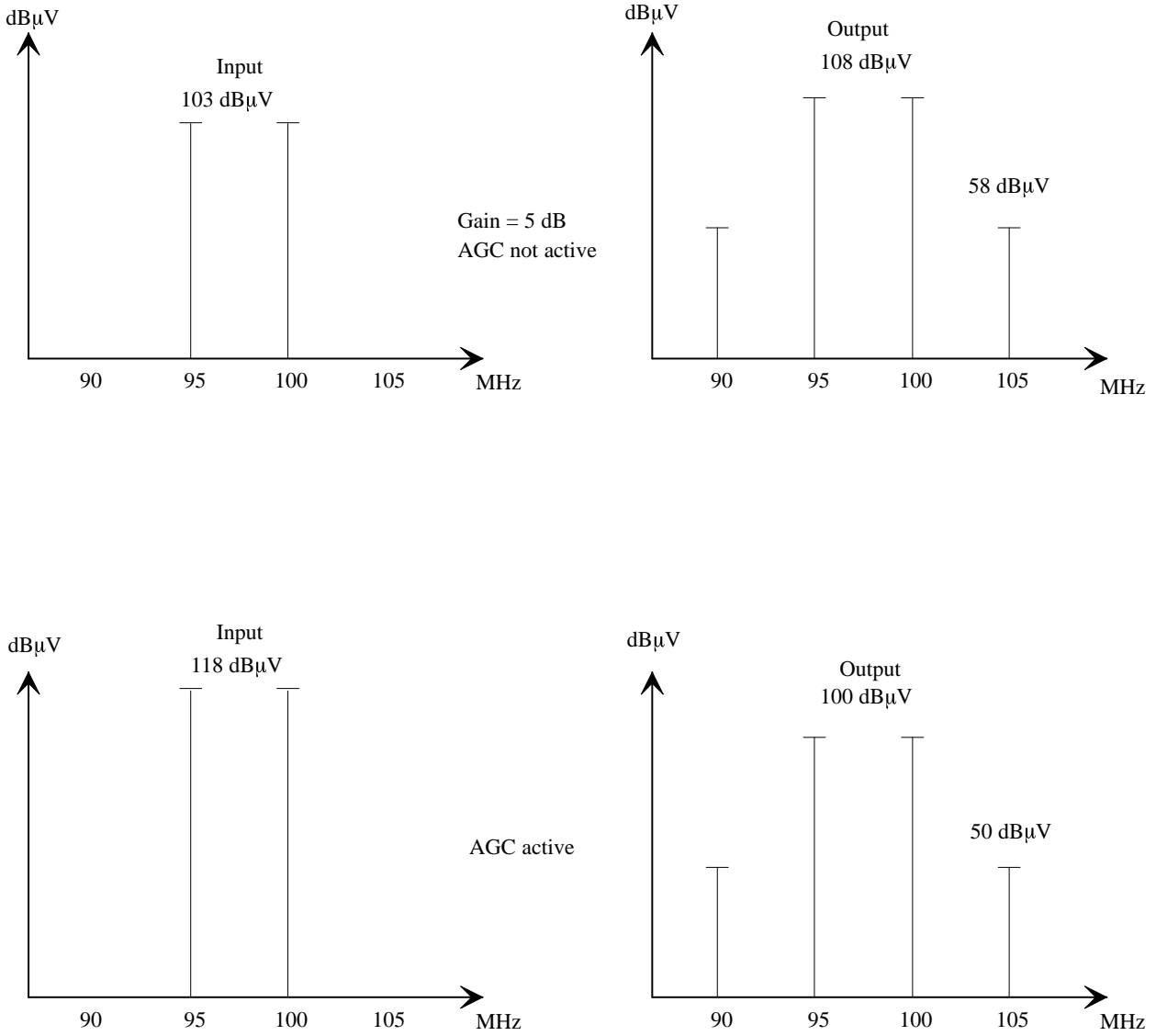

12400

Figure 13.

**Test Circuit for AM Large Signal Behavior**

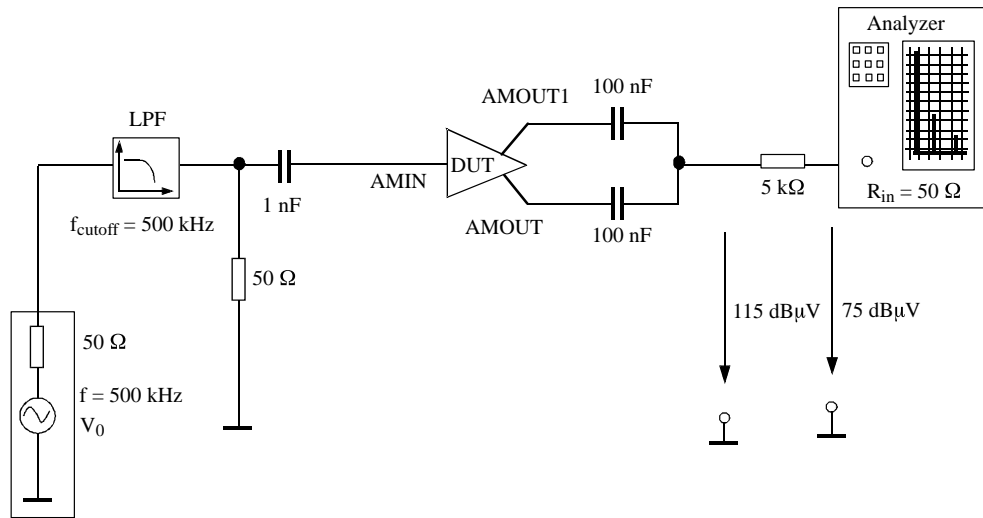

13935

Figure 14.

**AM Harmonic Distortion**

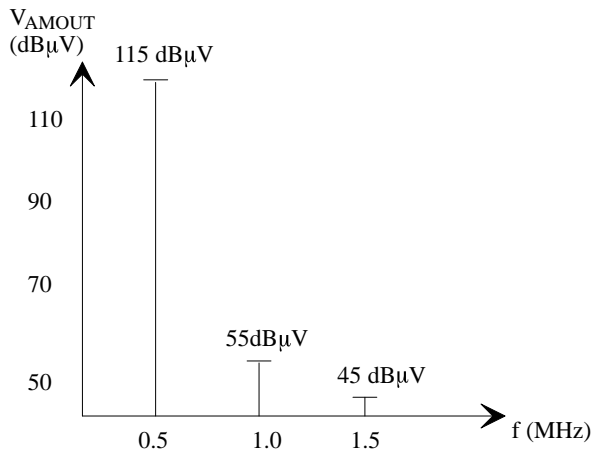

13936

Figure 15.

## Application Circuit

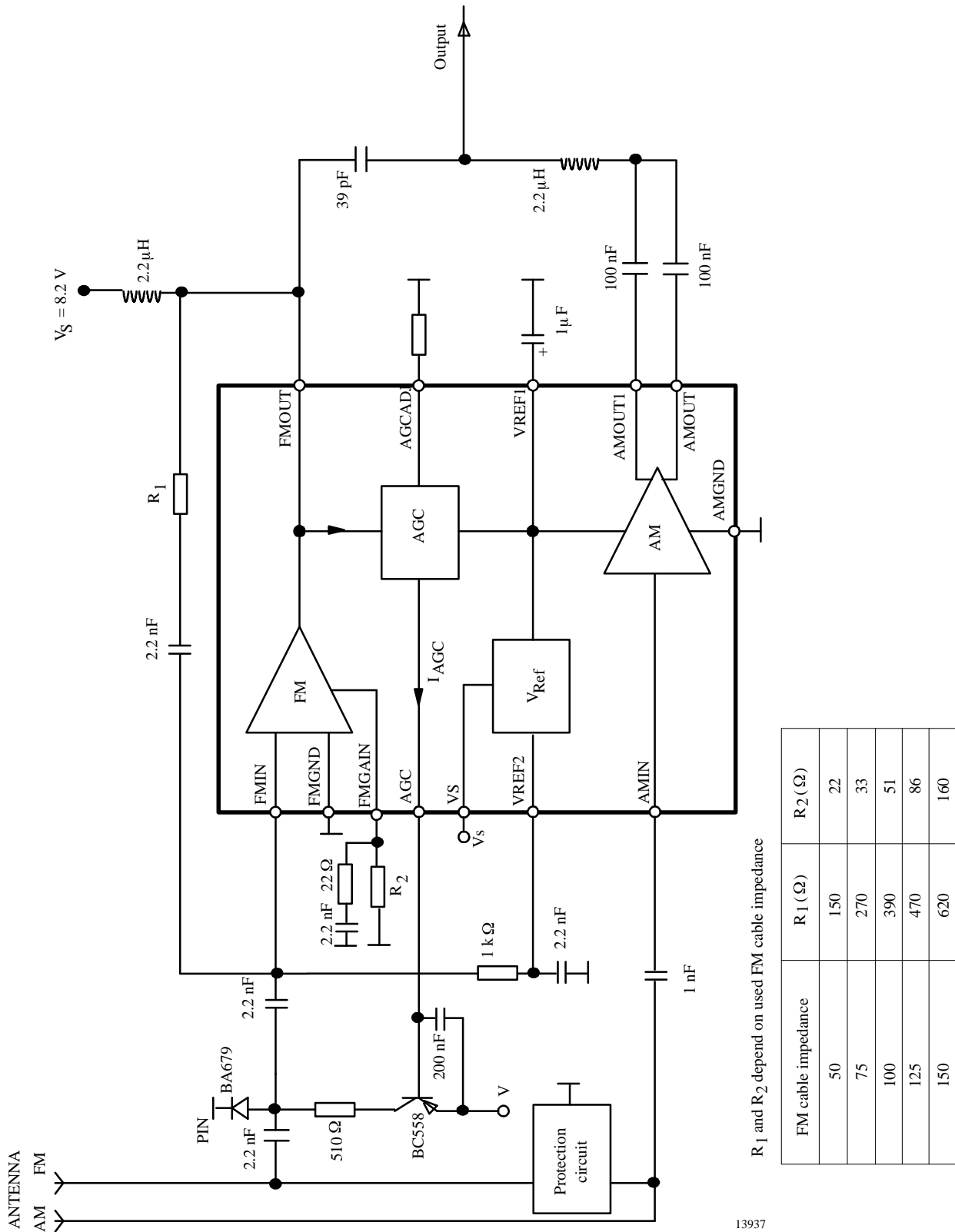
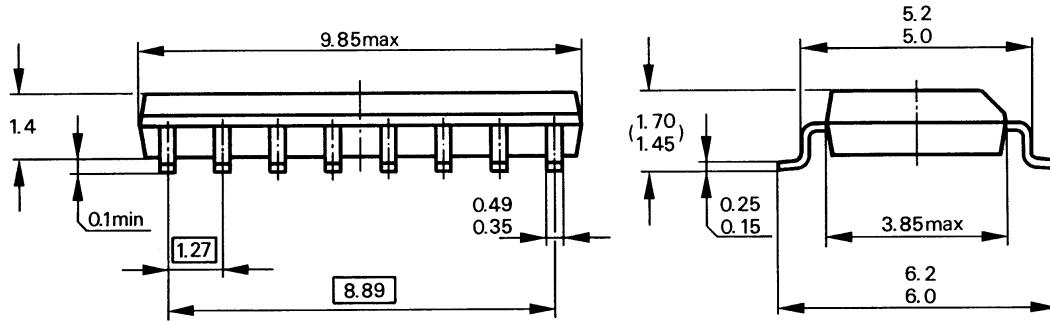

Figure 16.

**Package Information**

Package SO16  
Dimensions in mm



94 8875

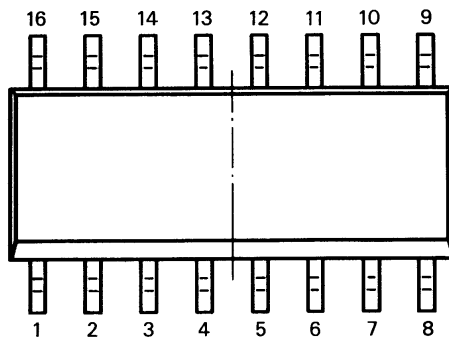

  
technical drawings  
according to DIN  
specifications

## Ozone Depleting Substances Policy Statement

It is the policy of **TEMIC TELEFUNKEN microelectronic GmbH** to

1. Meet all present and future national and international statutory requirements.
2. Regularly and continuously improve the performance of our products, processes, distribution and operating systems with respect to their impact on the health and safety of our employees and the public, as well as their impact on the environment.

It is particular concern to control or eliminate releases of those substances into the atmosphere which are known as ozone depleting substances (ODSs).

The Montreal Protocol (1987) and its London Amendments (1990) intend to severely restrict the use of ODSs and forbid their use within the next ten years. Various national and international initiatives are pressing for an earlier ban on these substances.

**TEMIC TELEFUNKEN microelectronic GmbH** semiconductor division has been able to use its policy of continuous improvements to eliminate the use of ODSs listed in the following documents.

1. Annex A, B and list of transitional substances of the Montreal Protocol and the London Amendments respectively
2. Class I and II ozone depleting substances in the Clean Air Act Amendments of 1990 by the Environmental Protection Agency (EPA) in the USA
3. Council Decision 88/540/EEC and 91/690/EEC Annex A, B and C (transitional substances) respectively.

**TEMIC** can certify that our semiconductors are not manufactured with ozone depleting substances and do not contain such substances.

**We reserve the right to make changes to improve technical design and may do so without further notice.**

Parameters can vary in different applications. All operating parameters must be validated for each customer application by the customer. Should the buyer use TEMIC products for any unintended or unauthorized application, the buyer shall indemnify TEMIC against all claims, costs, damages, and expenses, arising out of, directly or indirectly, any claim of personal damage, injury or death associated with such unintended or unauthorized use.

TEMIC TELEFUNKEN microelectronic GmbH, P.O.B. 3535, D-74025 Heilbronn, Germany  
Telephone: 49 (0)7131 67 2831, Fax number: 49 (0)7131 67 2423