



C4 Picasso
 C4 (B50 - B51 - B71)
 C3 Picasso
 C3 (A51)
 DS3
 DS4 (B75)
 C5 Tourer (X72)
 Berlingo (B9 VP)



207 (A70-A71-A72)
 407 SW (D22)
 508 SW (W22)
 308 (T70-T71-T72)
 Partner (B9 VP)
 3008
 5008

ACT: 1718
 Réf.: 9711.GG

FR NOTICE DE POSE A USAGE PROFESSIONNEL / PHOTOS ET DESSINS NON CONTRACTUELS
 GB FITTING INSTRUCTIONS FOR PROFESSIONAL FITTERS / PICTURES AND DRAWINGS
 ES INSTRUCCIONES DE MONTAJE PARA USO PROFESIONAL / FOTOS Y DIBUJOS SIN
 P MANUAL DE MONTAGEM PARA UTILIZAÇÃO PROFISSIONAL / FOTOGRAFIAS E DESENHOS
 DE MONTAGEANLEITUNG FÜR PROFESSIONNELLEN EINSATZ / NICHT VERTRAGSMÄSSIGE
 IT ISTRUZIONI DI POSA AD USO PROFESSIONALE / FOTO E DISEGNI NON CONTRATTUALI
 NL MONTAGEHANDLEIDING VOOR PROFESSIONEEL GEBRUIK / FOTO'S EN TEKENINGEN

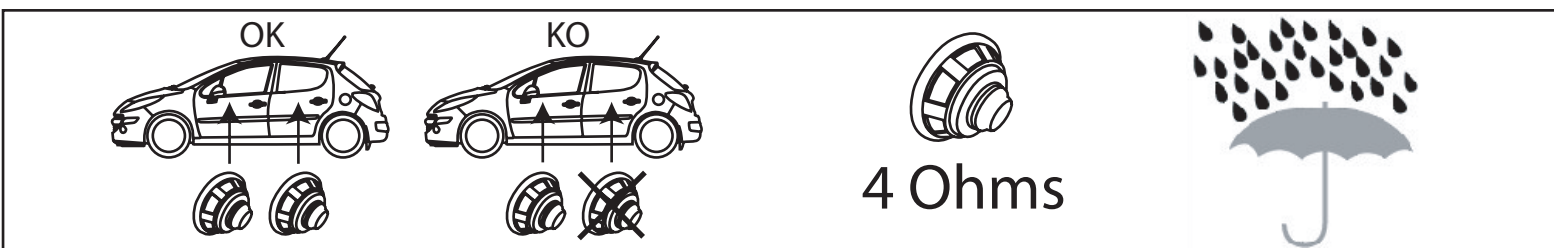
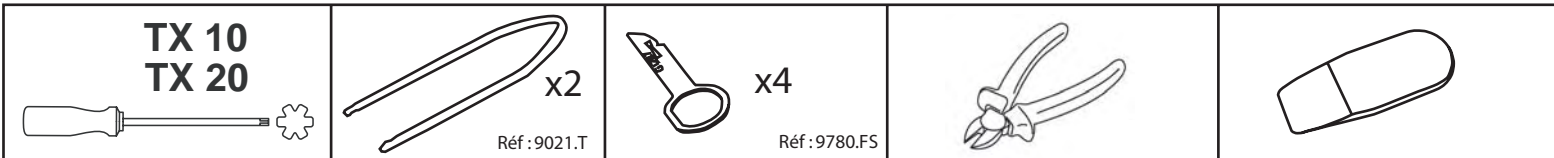
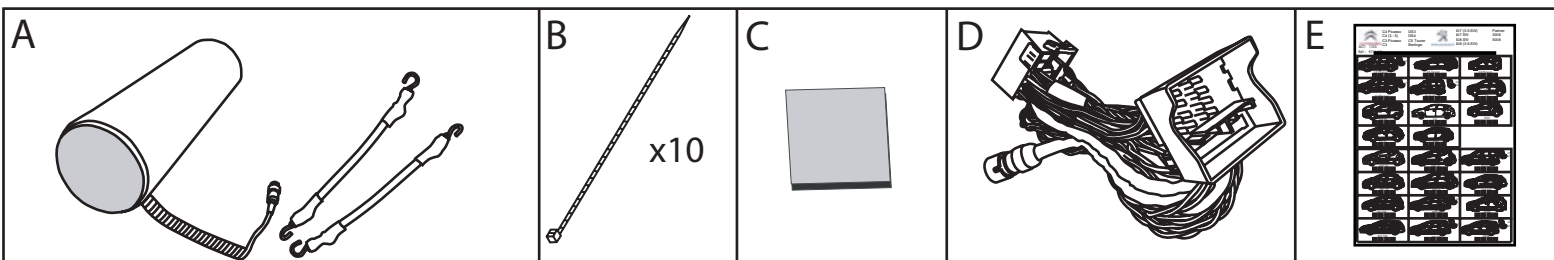
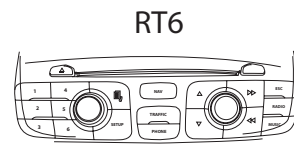
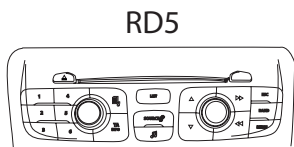
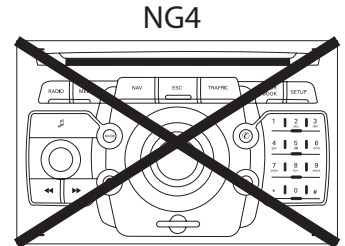
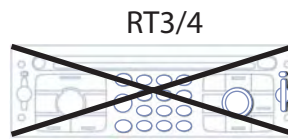
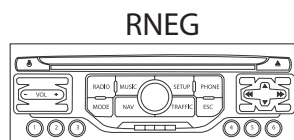

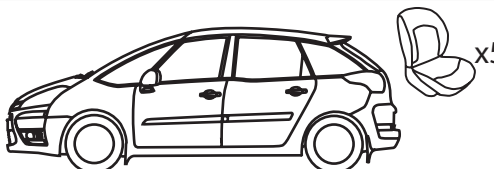

C4 Picasso
 $1 \rightarrow 12 + 13 + 20 + 21 + 22$

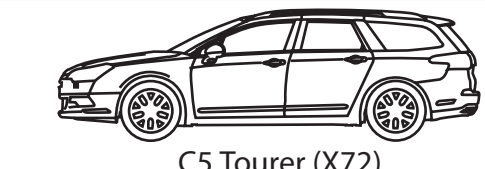

C5 Tourer (X72)
 $1 \rightarrow 12 + 18 + 20 + 21 + 22$



C3 Picasso
 $1 \rightarrow 12 + 16 + 20 + 21 + 22$

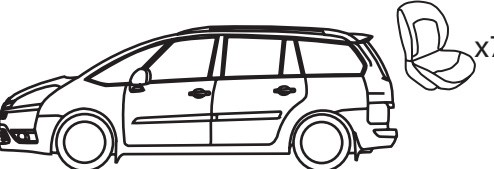

C4 Picasso
 $1 \rightarrow 12 + 13 + 20 + 21 + 22$



Berlingo (B9 VP)
 $1 \rightarrow 12 + 13 + 20 + 21 + 22$



C3 (A51)
 $1 \rightarrow 12 + 18 + 20 + 21 + 22$



C4 (B50)
 $1 \rightarrow 12 + 15 + 20 + 21 + 22$

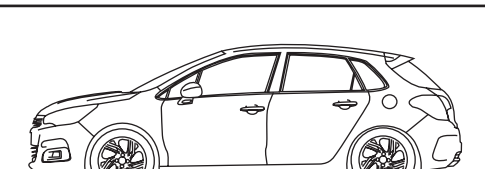

C4 (B71)
 $1 \rightarrow 12 + 19 + 20 + 21 + 22$

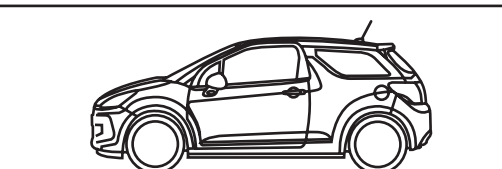

DS3
 $1 \rightarrow 12 + 18 + 20 + 21 + 22$

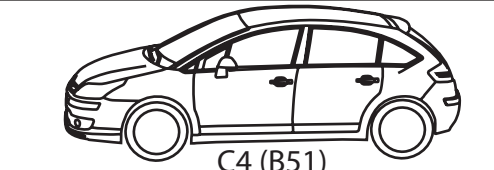

C4 (B51)
 $1 \rightarrow 12 + 15 + 20 + 21 + 22$

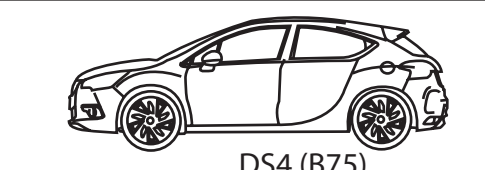

DS4 (B75)
 $1 \rightarrow 12 + 19 + 20 + 21 + 22$

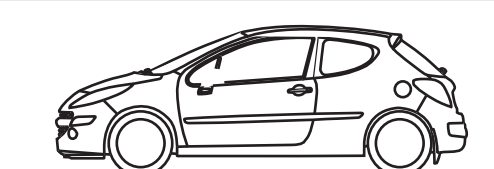

207 (A70)
 $1 \rightarrow 12 + 14 + 20 + 21 + 22$



308 (T70)
 $1 \rightarrow 12 + 18 + 20 + 21 + 22$



Partner (B9 VP)
 $1 \rightarrow 12 + 13 + 20 + 21 + 22$



207 (A71)
 $1 \rightarrow 12 + 14 + 20 + 21 + 22$



308 (T71)
 $1 \rightarrow 12 + 18 + 20 + 21 + 22$

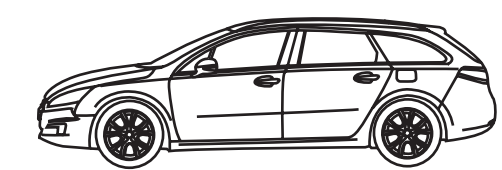

508 SW (W22)
 $1 \rightarrow 12 + 18 + 20 + 21 + 22$



207 SW (A72)
 $1 \rightarrow 12 + 16 + 20 + 21 + 22$

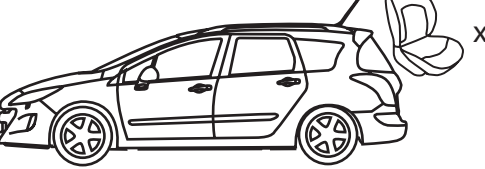

308 SW (T72)
 $1 \rightarrow 12 + 17 + 20 + 21 + 22$



3008
 $1 \rightarrow 12 + 18 + 20 + 21 + 22$



407 SW (D22)
 $1 \rightarrow 12 + 18 + 20 + 21 + 22$



308 SW (T72)
 $1 \rightarrow 12 + 13 + 20 + 21 + 22$

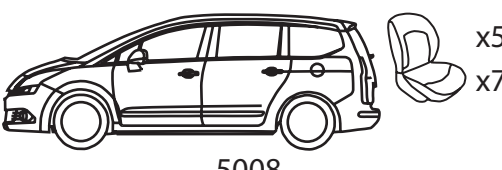

5008
 $1 \rightarrow 12 + 13 + 20 + 21 + 22$

1

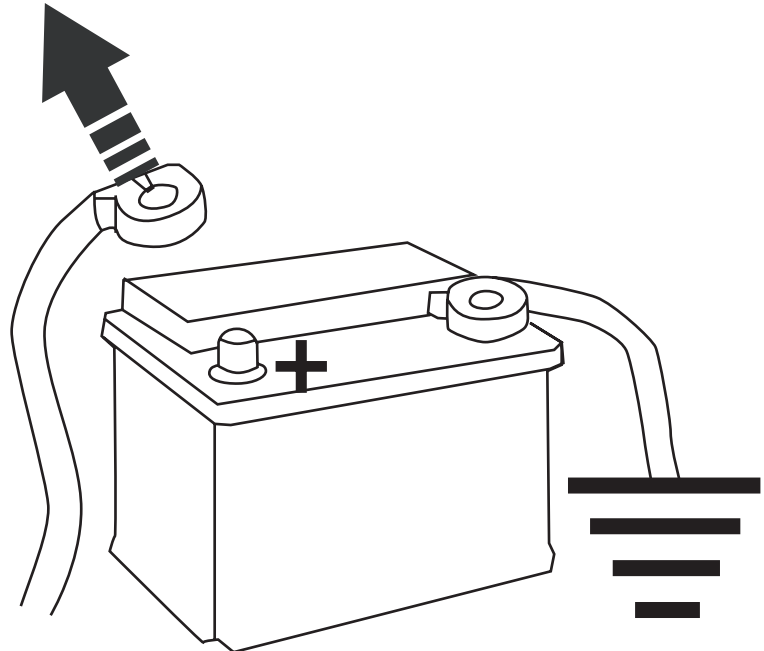

2

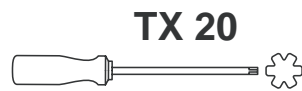
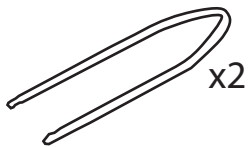
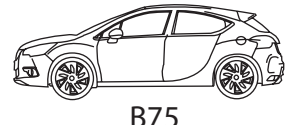
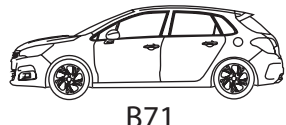
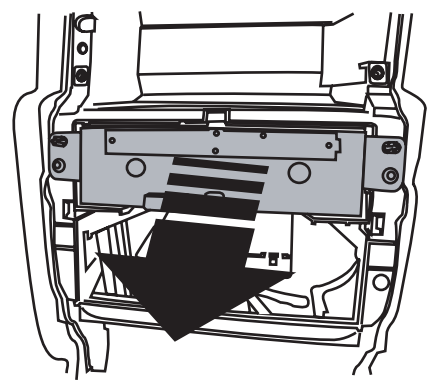
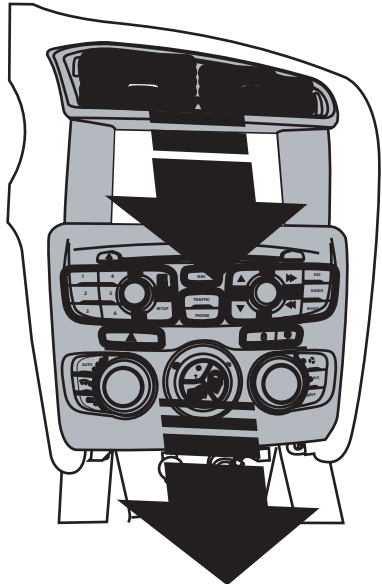
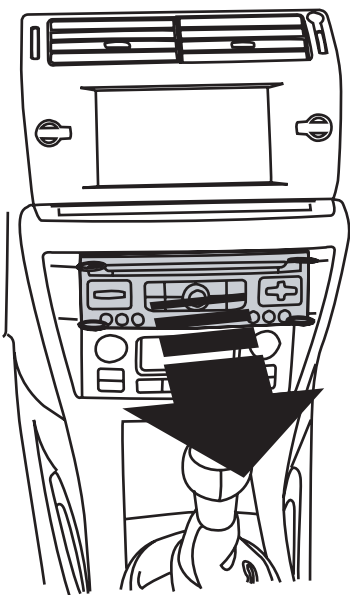

3

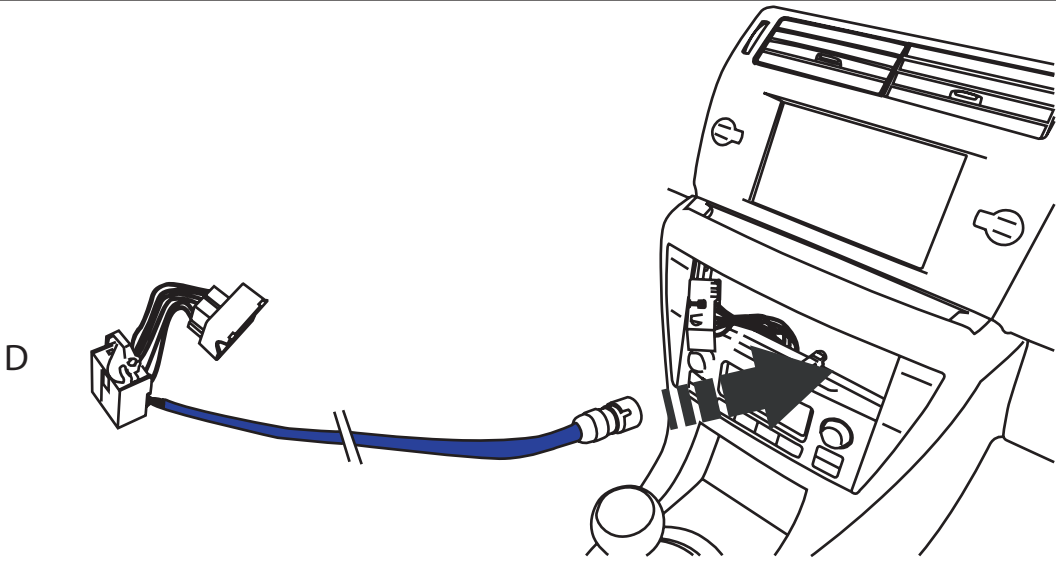

4

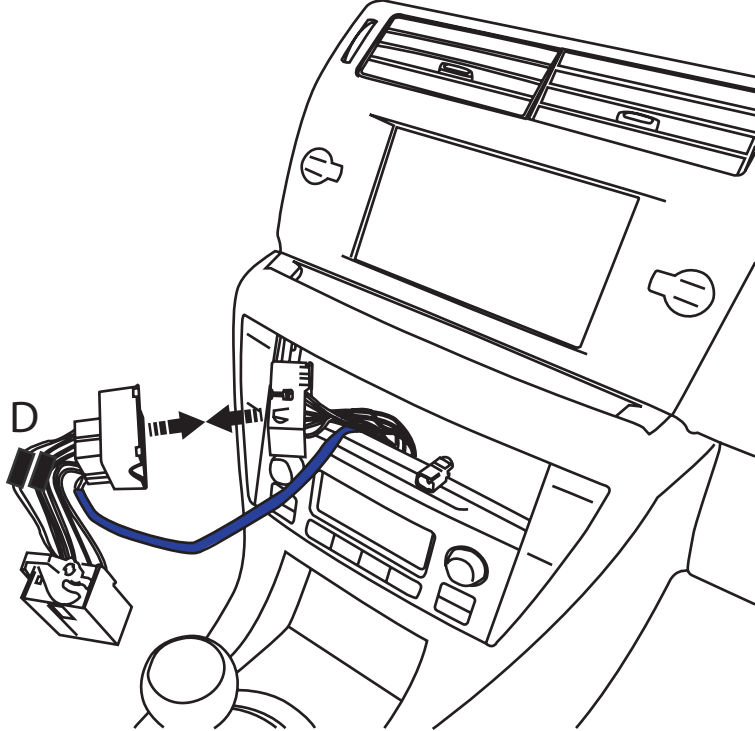

5

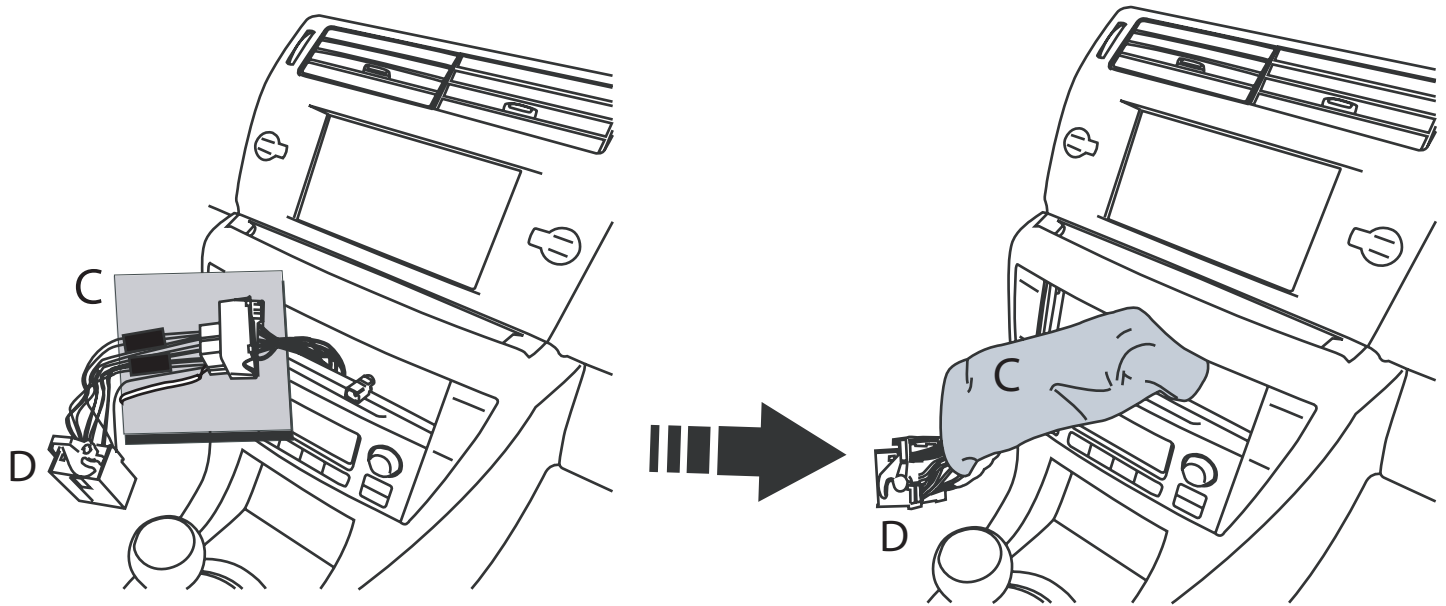

6

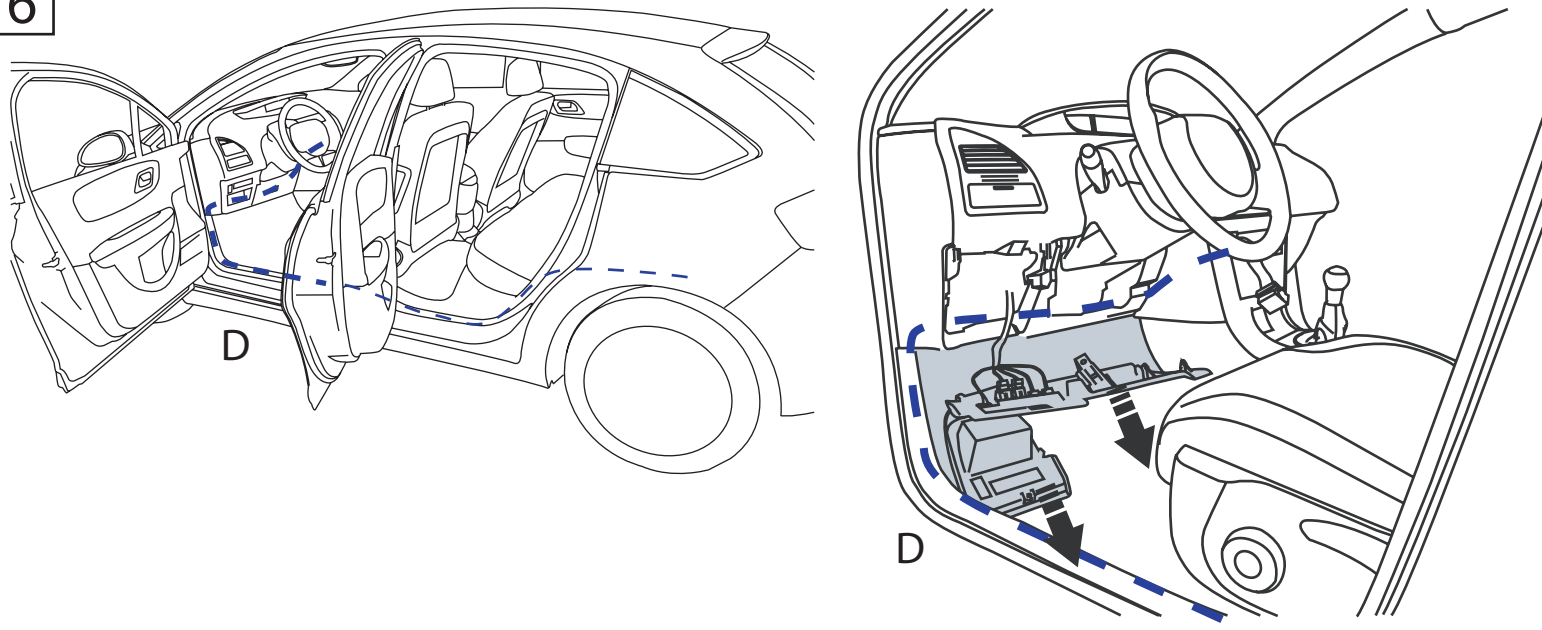

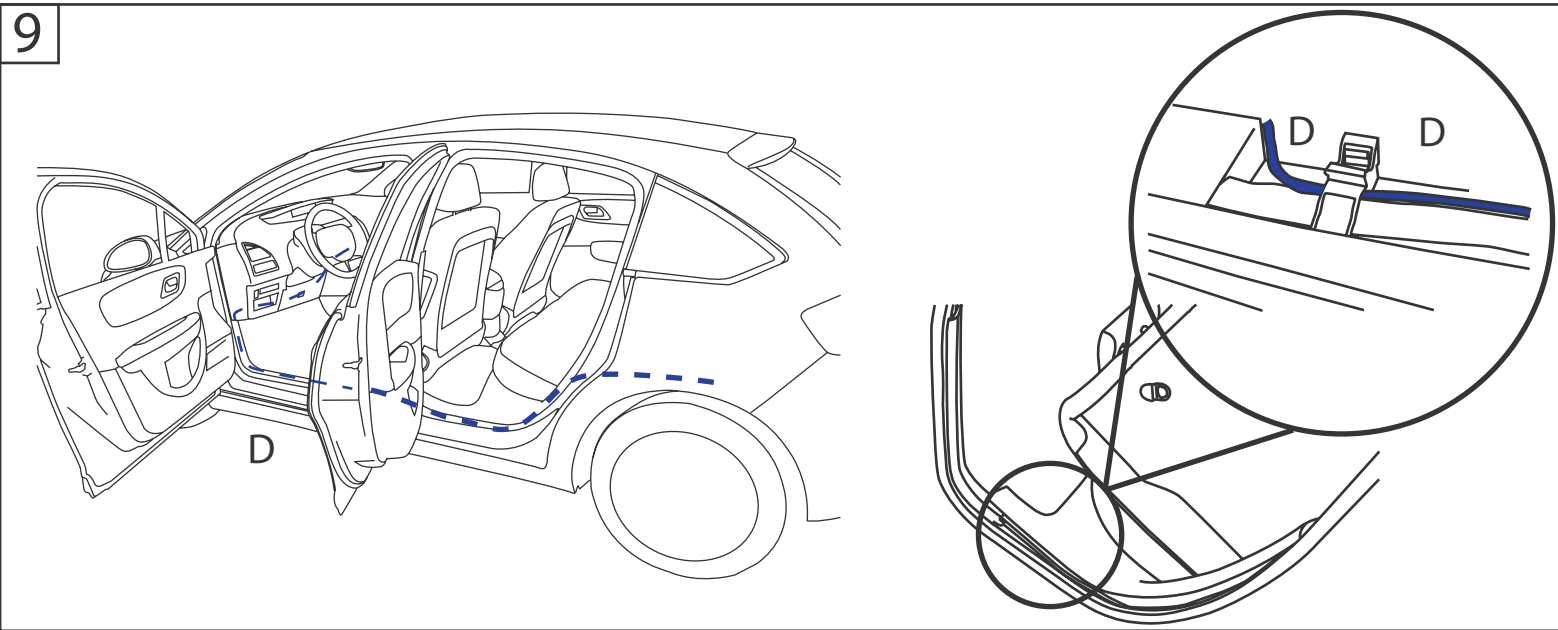
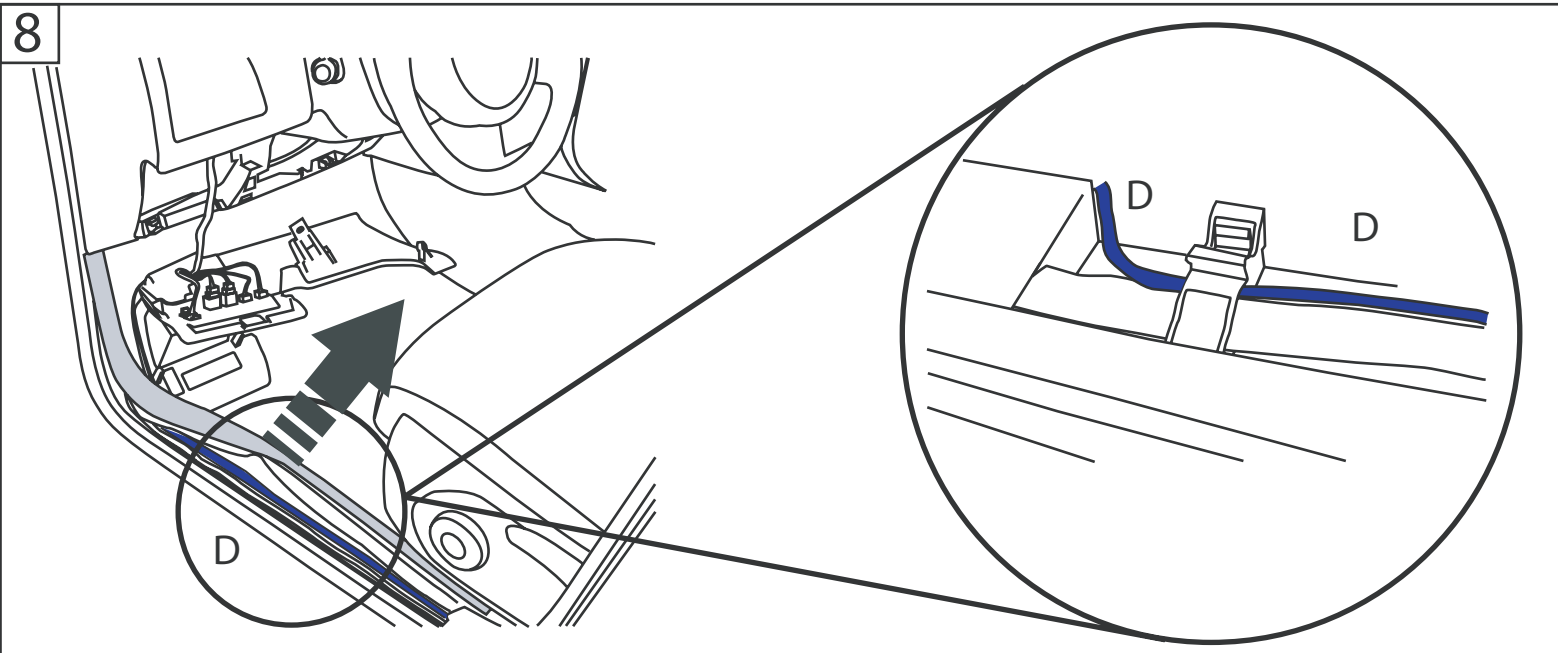
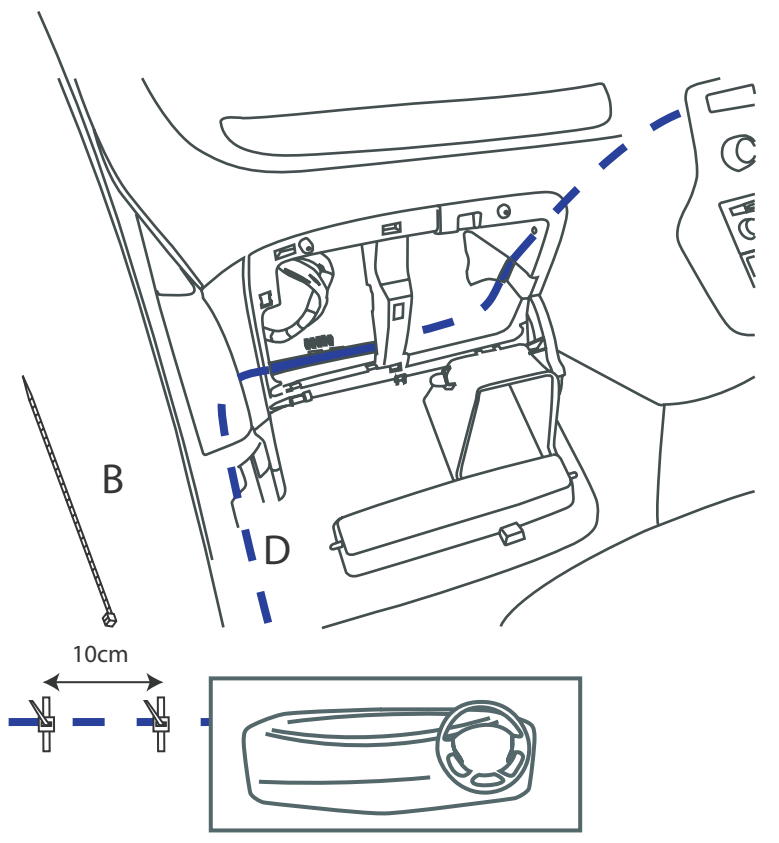
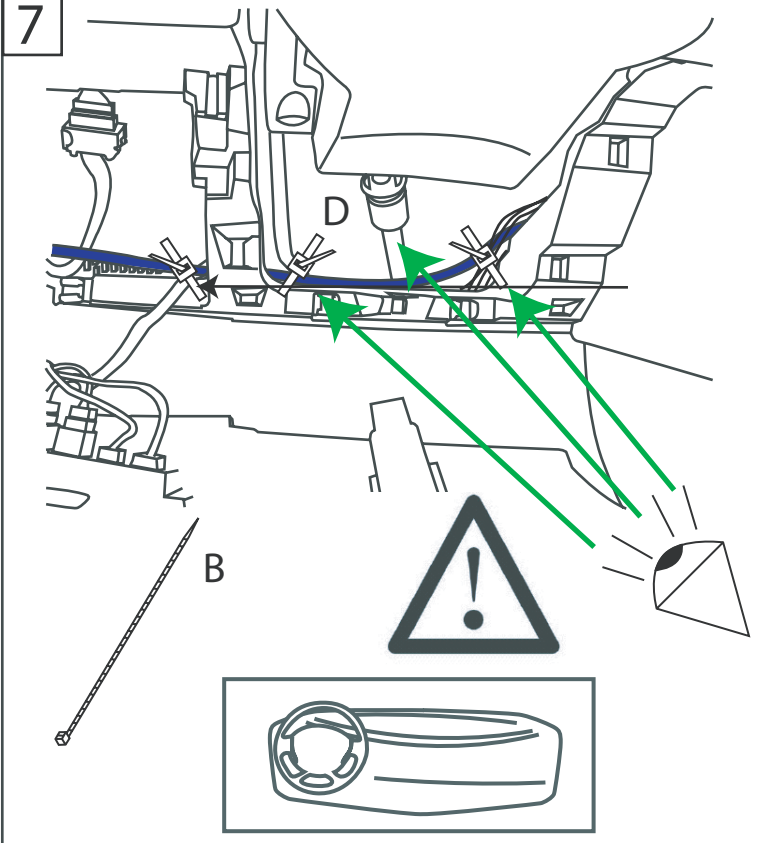

10

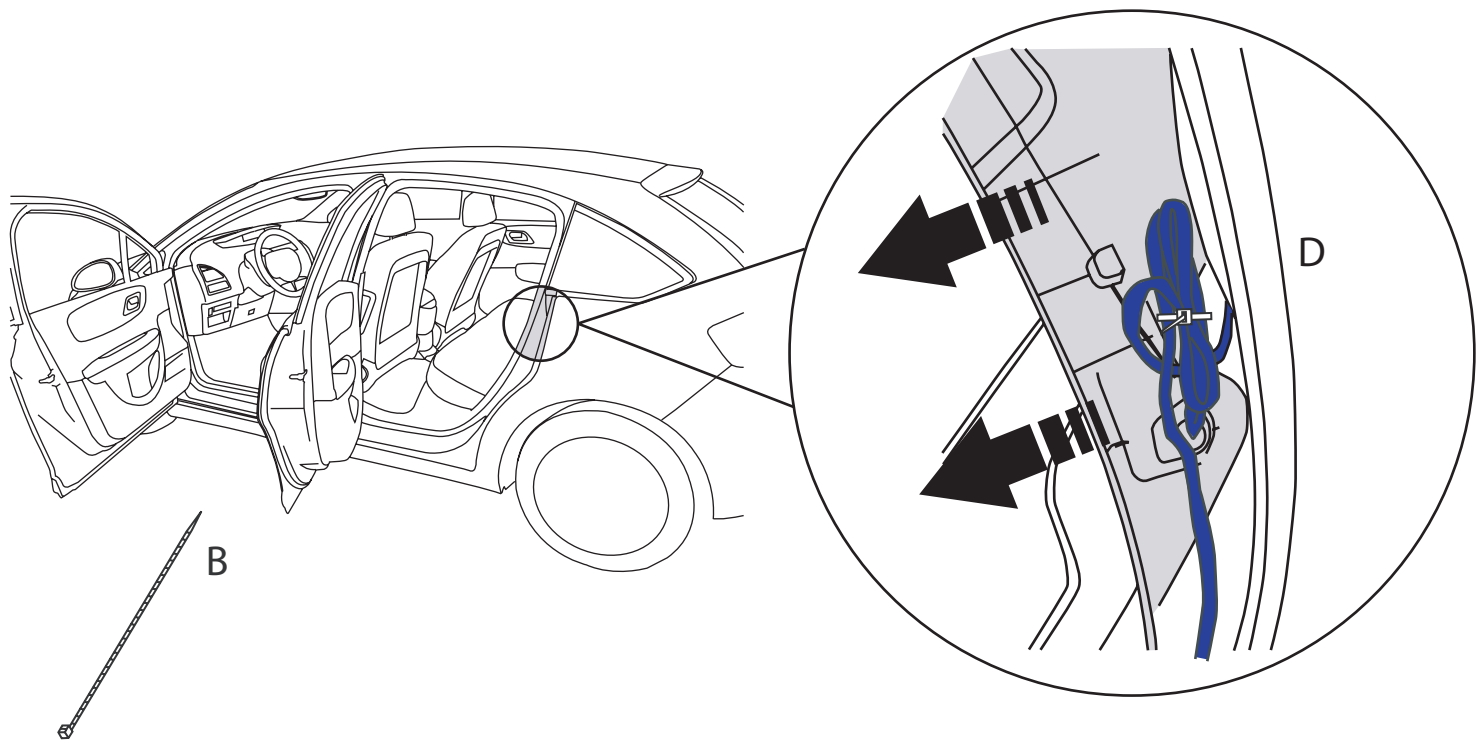

11

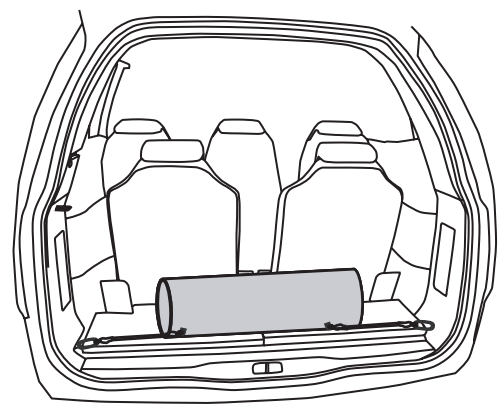
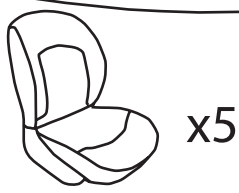
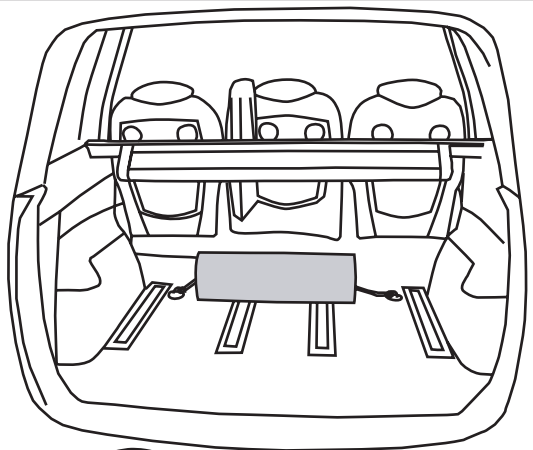

12

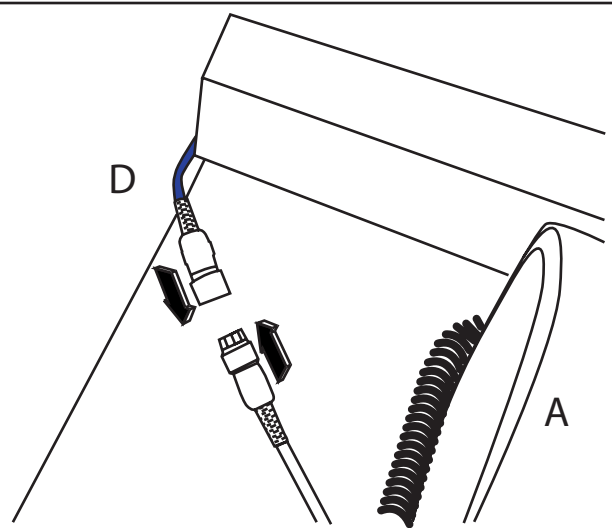

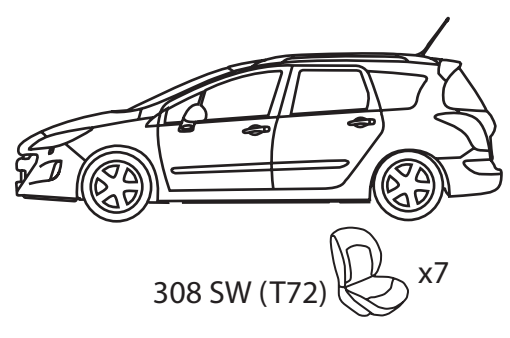
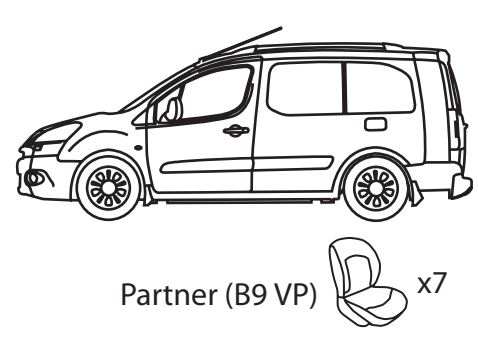
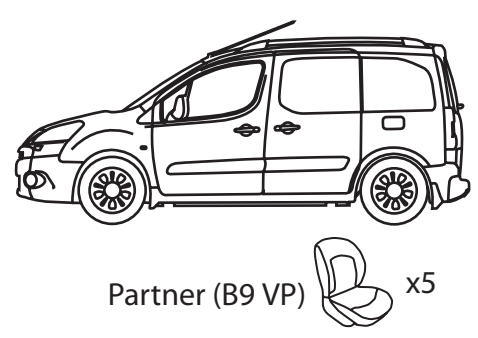
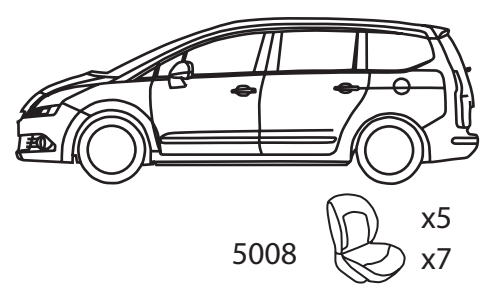
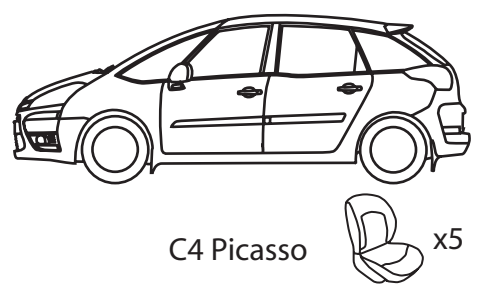
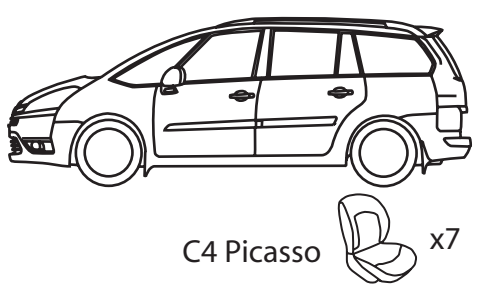
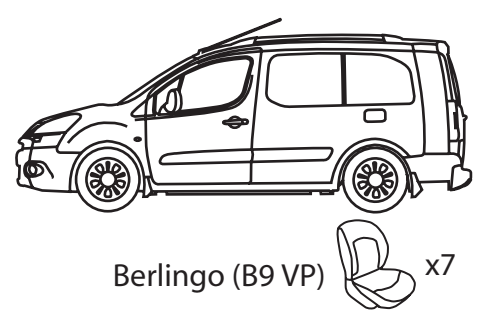
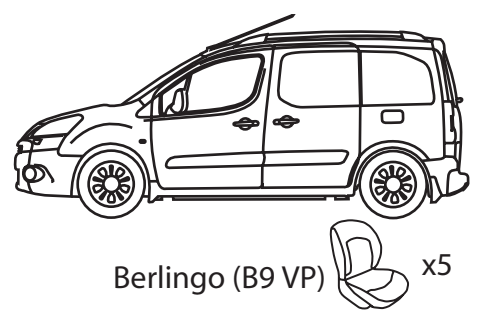

14

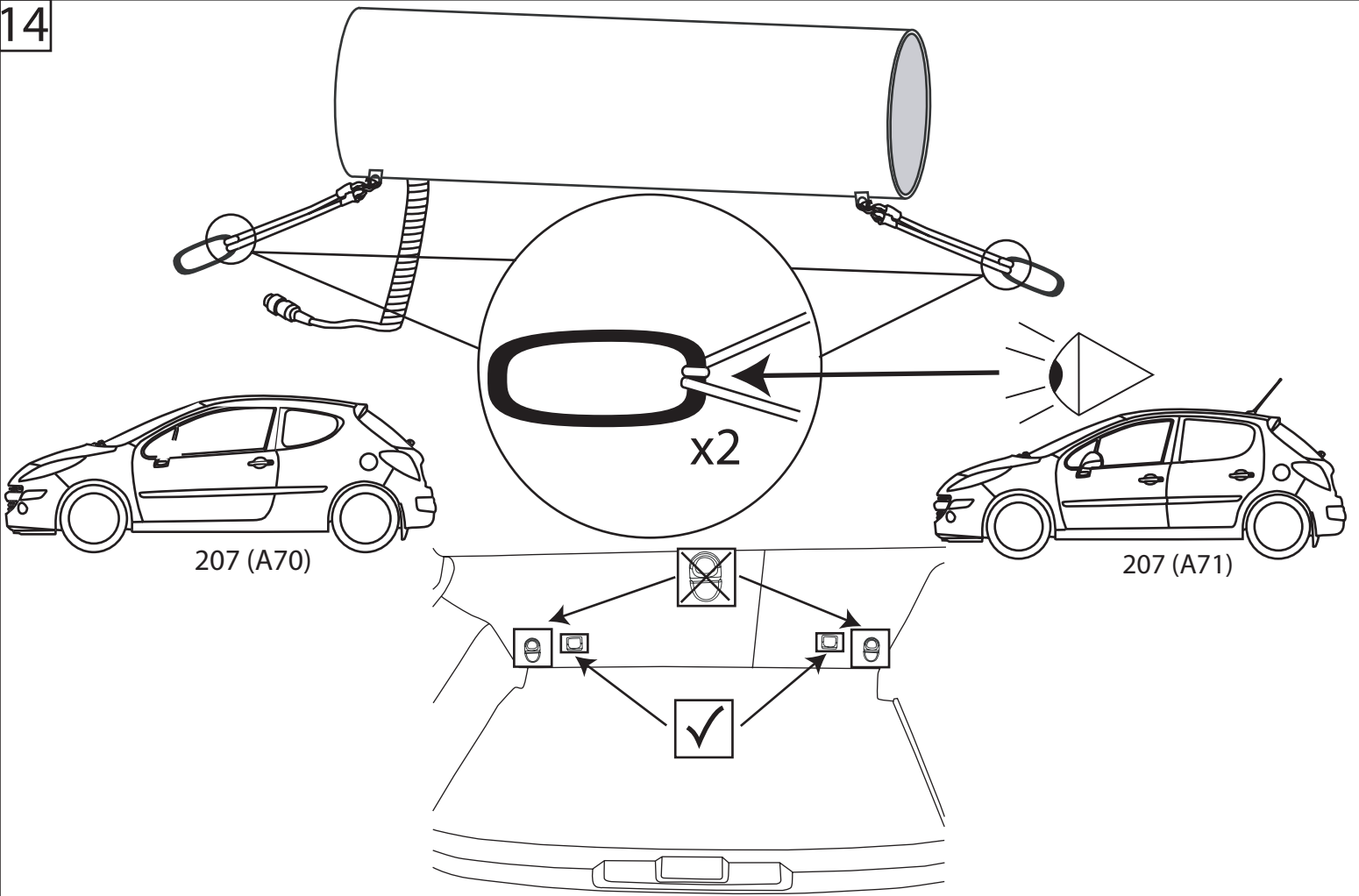

15

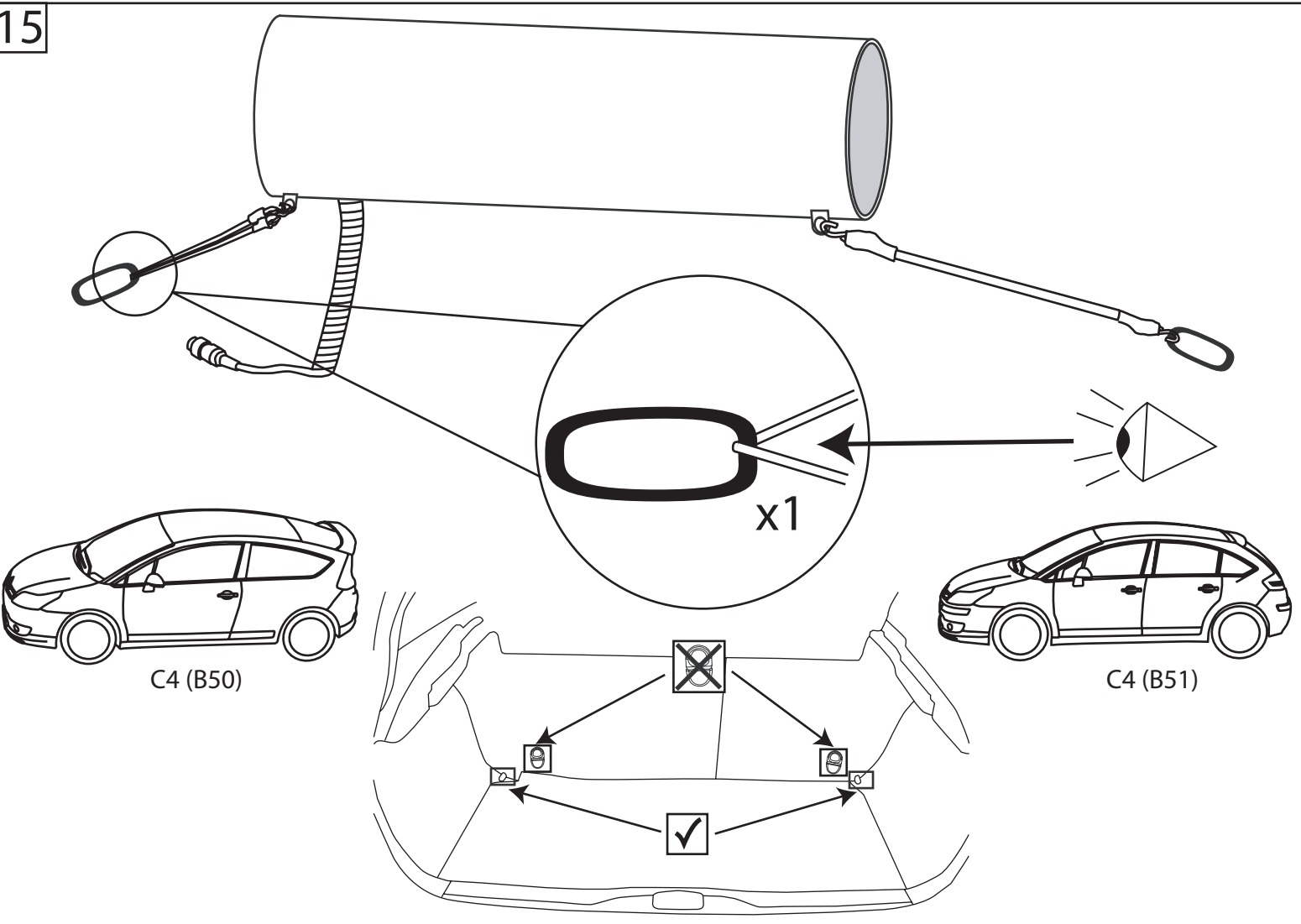

16

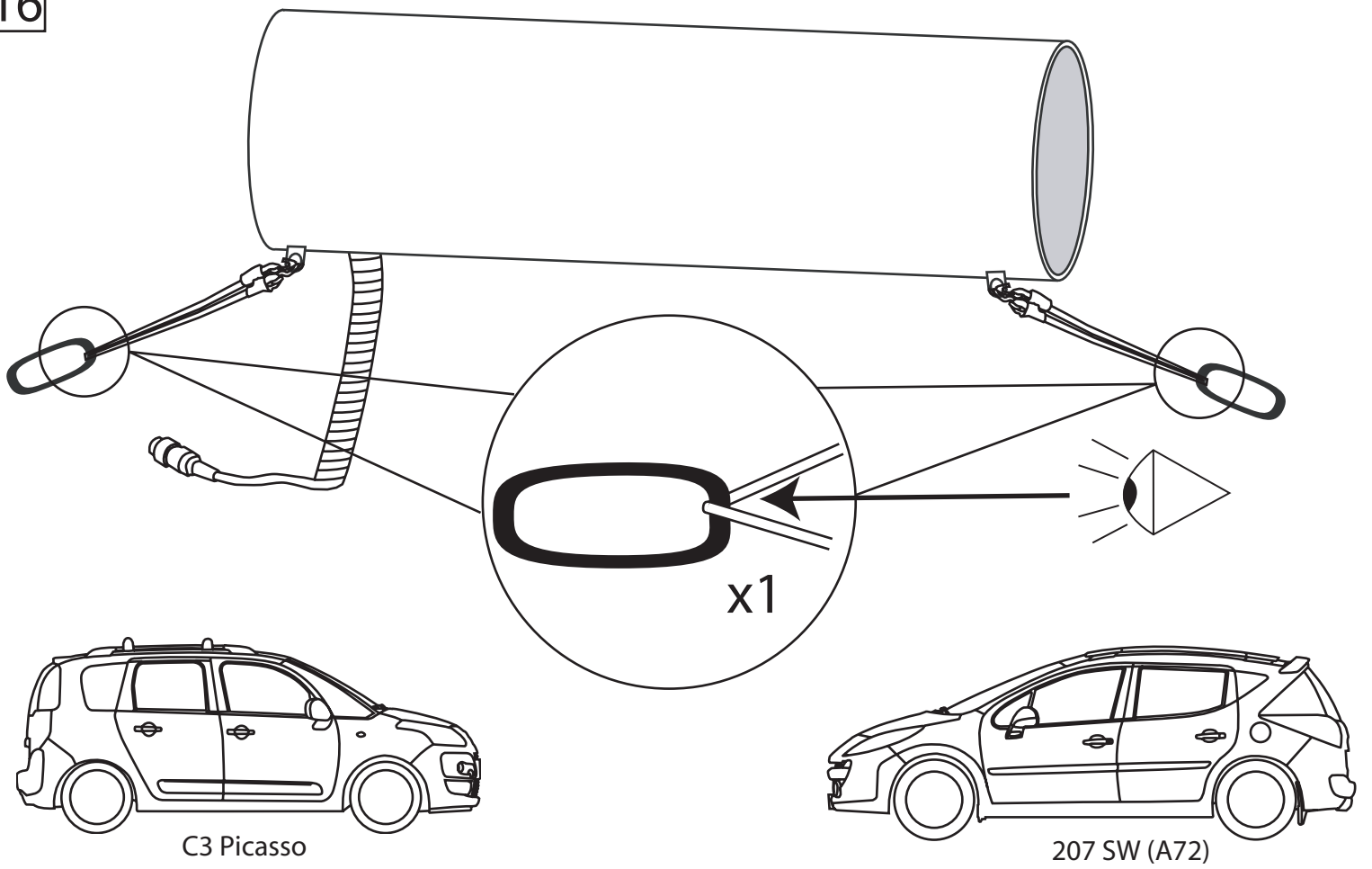

17

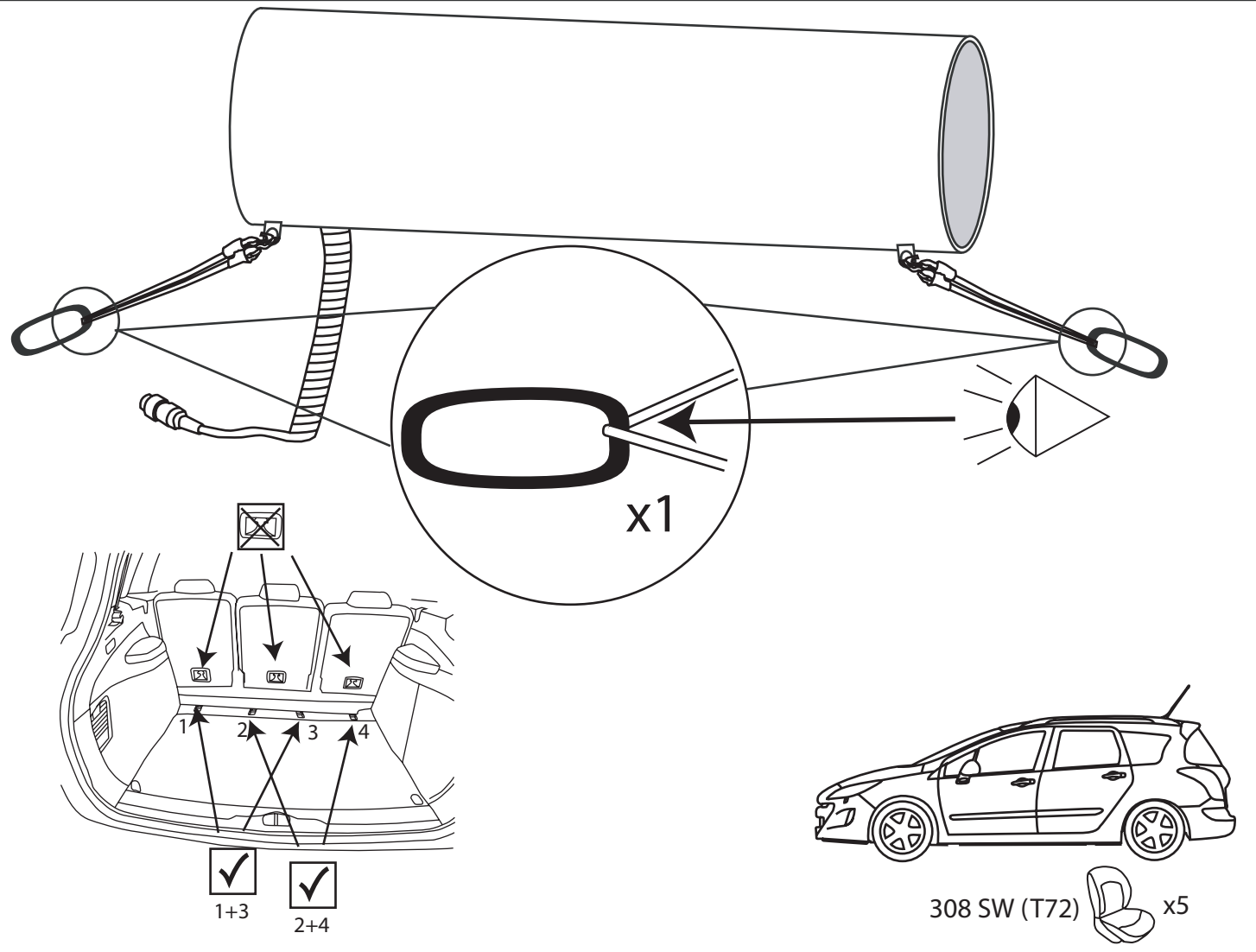

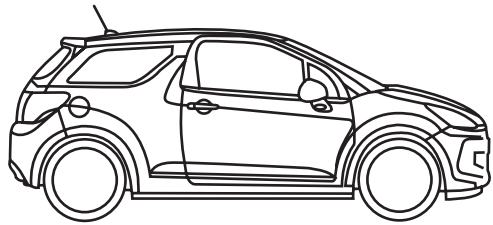
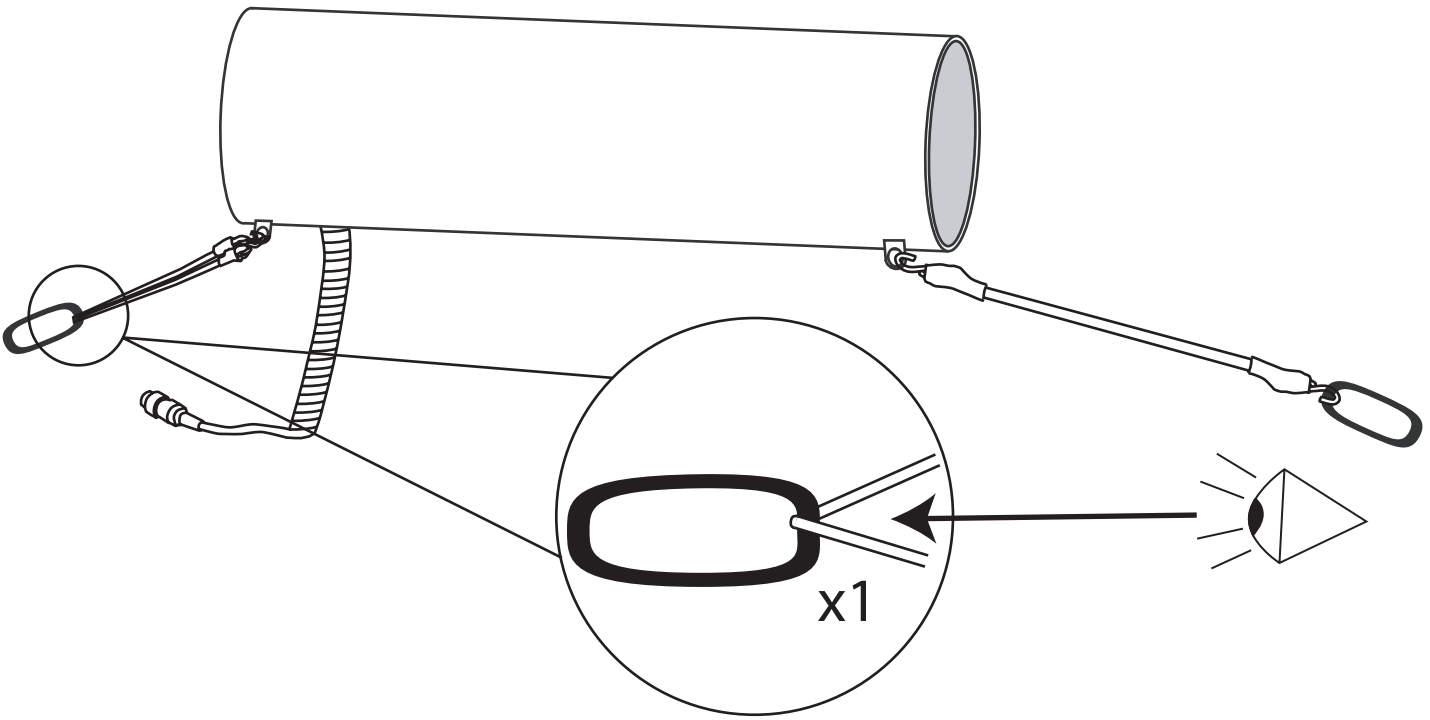

DS3

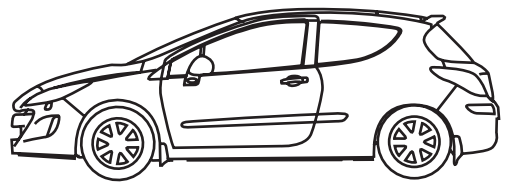

308 (T70)

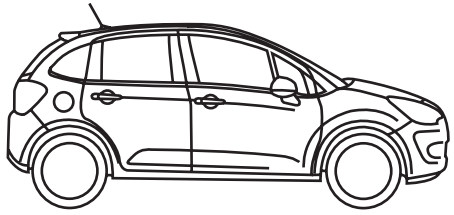

C3 (A51)

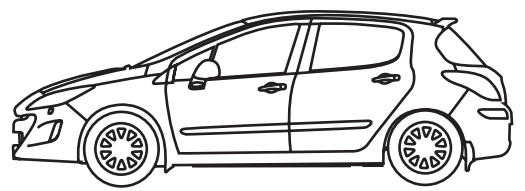

308 (T71)

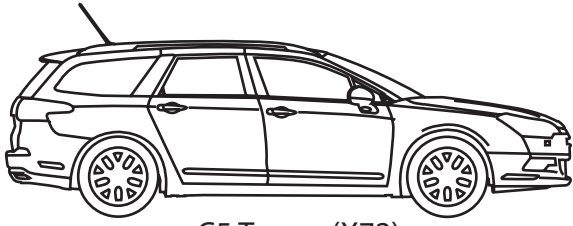

C5 Tourer (X72)

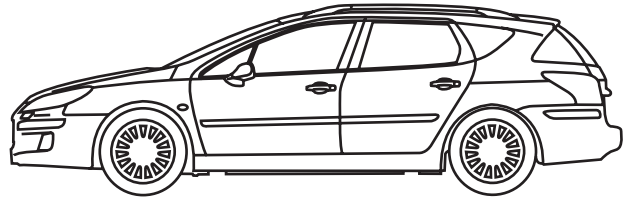

407 SW (D22)

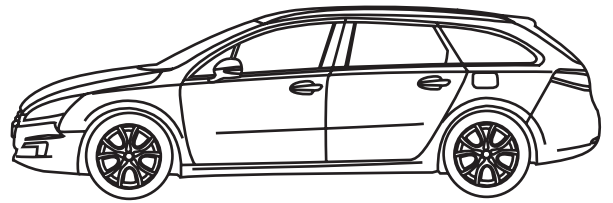

508 SW (W22)

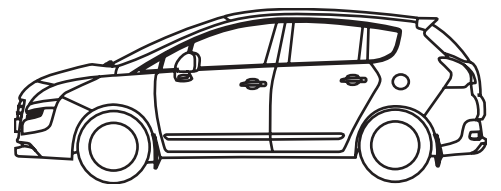

3008

19

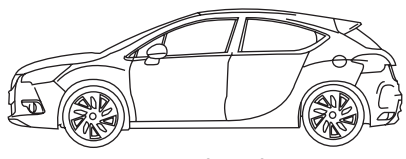
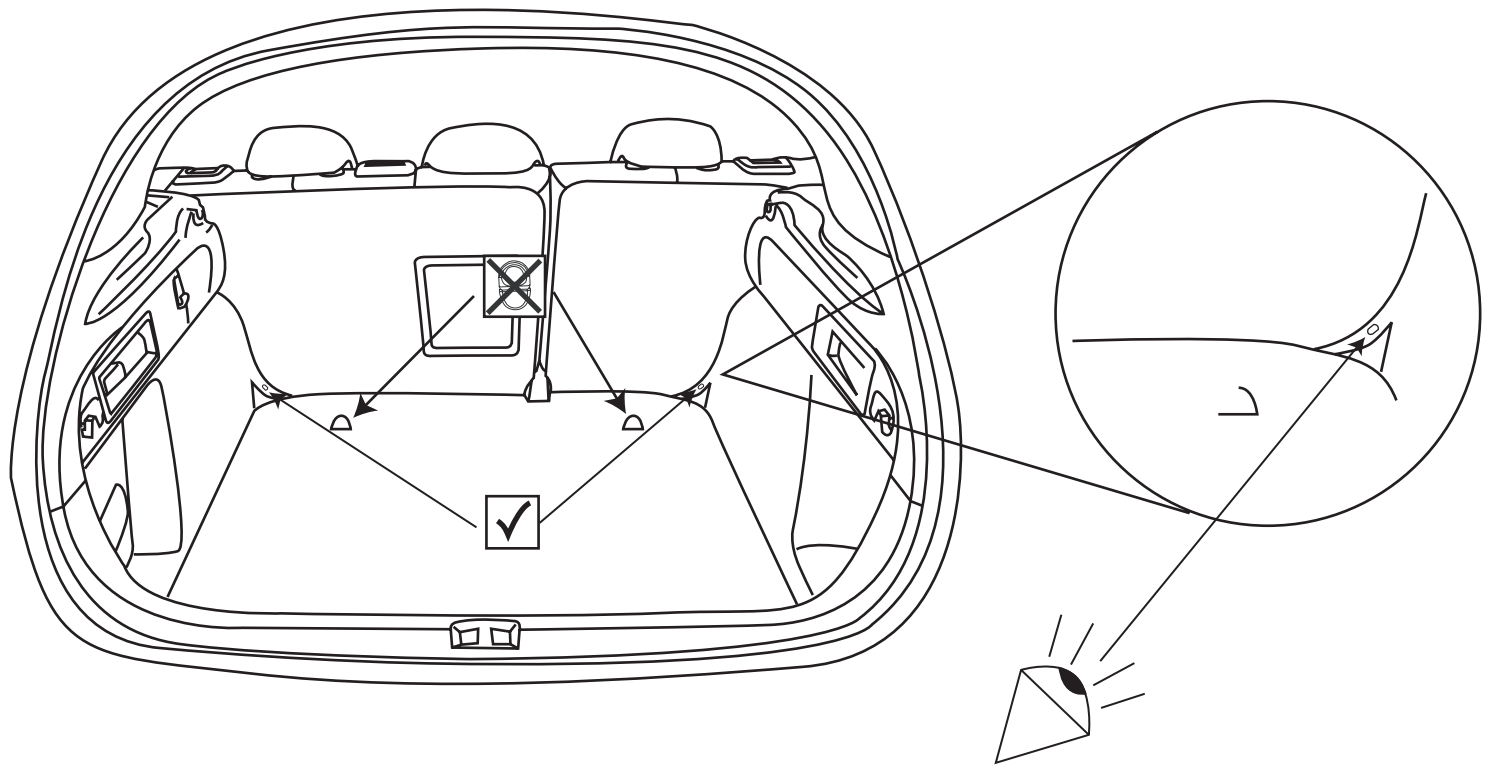

DS4 (B75)



C4 (B71)

20

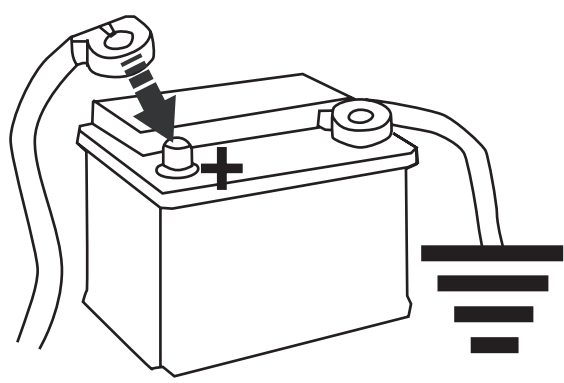

21

FADER = -3

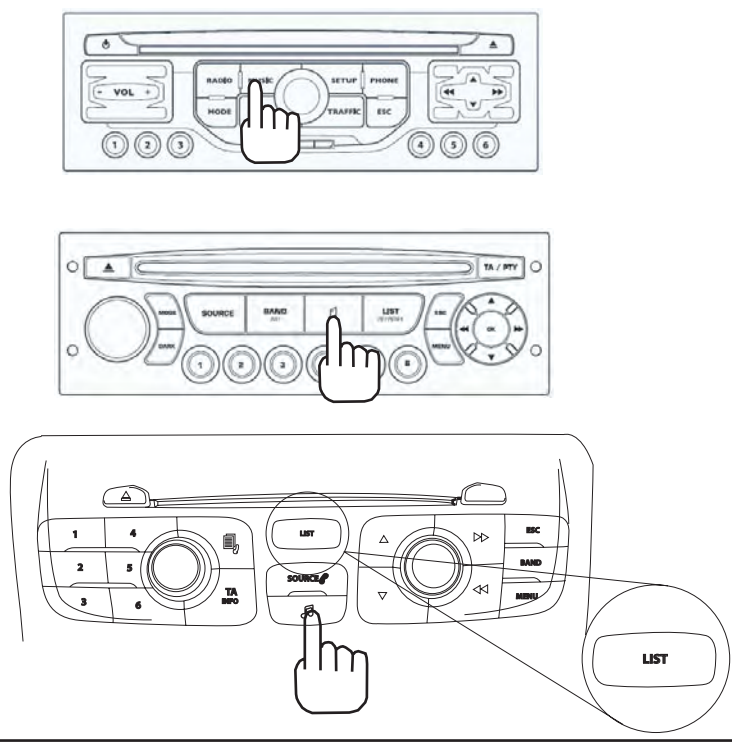

FADER = +3

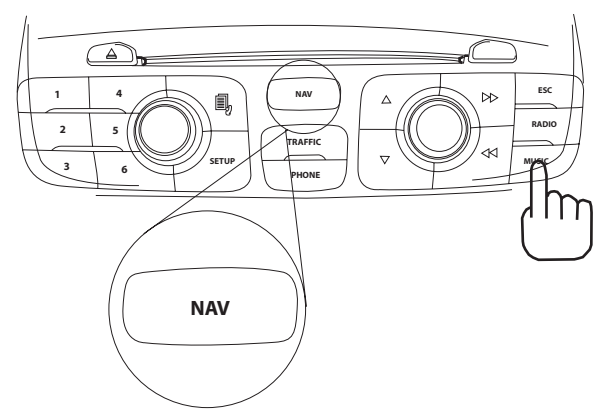

22

E

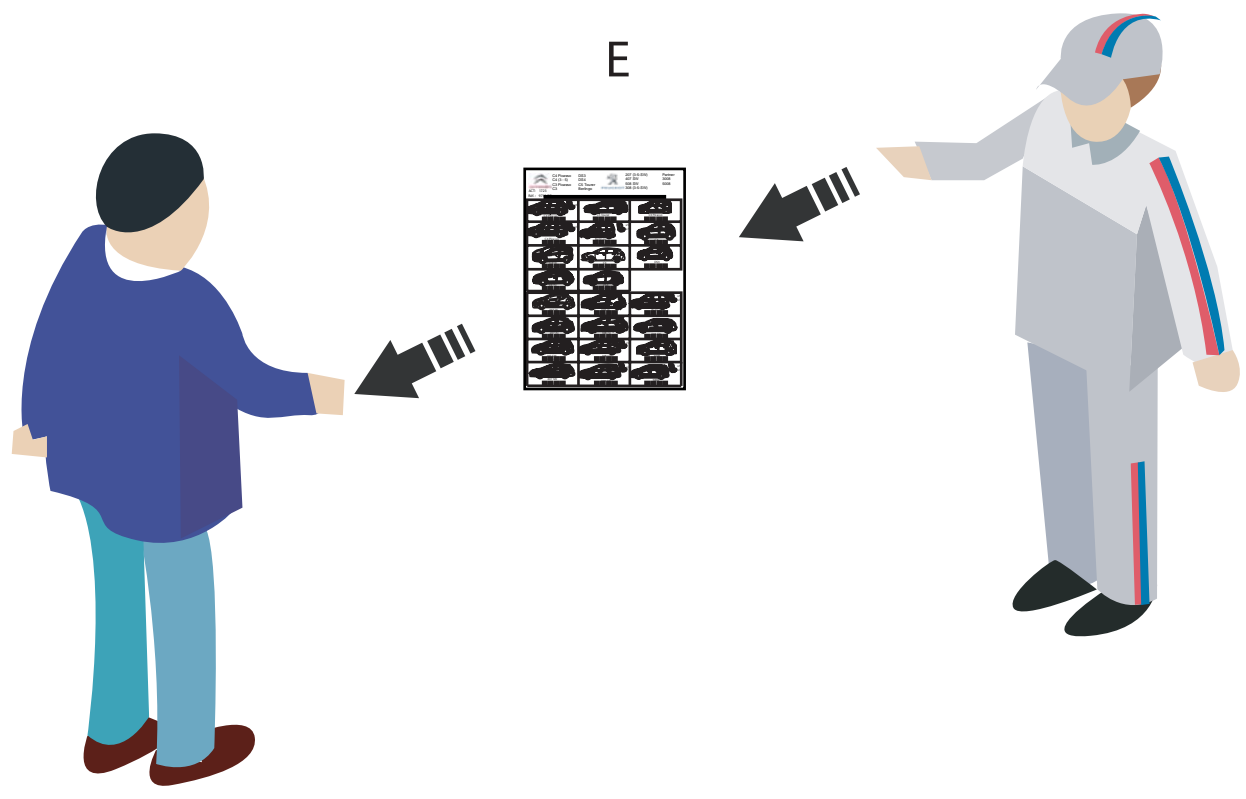

**IT****Non utilizzare il prodotto fissato quando i sedili sono ripiegati.**

Durante il montaggio del prodotto nel bagagliaio, l'ambiente deve essere completamente sgombro per evitare rischi di deterioramento e di ferite. Qualsiasi cambiamento di materiale (autoradio, amplificatore) che rischi di modificare l'ambiente può provocare un deterioramento o un disfunzionamento del materiale e deve quindi essere evitato.

PULIZIA:

In caso di sporcizia, il rivestimento va pulito con un panno asciutto o con acqua insaponata. Evitare l'uso di prodotti aggressivi e abrasivi.

NOTA:

In caso di mancato rispetto di queste istruzioni, PSA non potrà essere tenuta responsabile per quanto riguarda il corretto funzionamento del sistema e la sua durata di vita. Questo elenco di raccomandazioni non è esaustivo.

**NO****Høyttaleren må ikke brukes i festet stand dersom setene er foldet sammen.**

Ved montering i bagasjerommet skal man sørge for at alt er ryddig og at ingen gjenstander kan forårsake skader eller forringelse på høyttaleren. Enhver utskifting av materiell (bilradio, forsterker) fører til endringer i systemet, noe som kan medføre funksjonsfeil eller skade på høyttaleren. Denne typen utskifting skal derfor ikke foretas.

RENGJØRING:

Dersom det ytre trekket på høyttaleren er tilsmusset, kan det rengjøres enten med en tørr klut eller med mildt såpevann. Bruk ikke aggressive produkter eller skuremidler.

NB:

PSA kan ikke holdes ansvarlig for systemets funksjon og levetid dersom disse forholdsreglene ikke overholdes. Denne listen over forholdsregler er ikke endelig.

**PO****Não utilizar o produto fixo quando os bancos estiverem rebatidos.**

Aquando da montagem na mala, a área de trabalho deve estar perfeitamente livre para evitar o risco de danos e ferimentos. Qualquer alteração do material (auto-rádio, amplificador) susceptível de modificar o ambiente pode causar danos ou falhas do material, não devendo por isso ser efectuada.

LIMPEZA:

Em caso de presença de sujidade, o revestimento deve ser limpo com um pano seco ou com um pouco de água com sabão. Não devem utilizar-se produtos agressivos abrasivos.

NOTA:

O desrespeito destas recomendações não deverá, em qualquer circunstância, implicar a responsabilidade da PSA relativamente ao bom funcionamento do sistema e à respectiva vida útil. Esta lista de recomendações não é exaustiva.

**NL****Wanneer het product eenmaal is bevestigd niet gebruiken met neergeklapte stoelen.**

Tijdens de montage in de bagageruimte moet de omgeving volkomen ontruimd zijn om de kans op beschadiging en verwonding te vermijden. Elke verandering van materiaal (autoradio, versterker) die de omgeving zou kunnen wijzigen kan een verslechtering of een functiestoornis van het materiaal veroorzaken en moet daarom worden verboden.

REINIGING:

In geval van vuil moet de bekleding hetzij met een droge doek, hetzij met zeepwater worden gereinigd. Het gebruik van agressieve of schurende middelen moet worden uitgesloten.

NOTA:

In het geval dat deze instructies niet worden nageleefd kan PSA in geen geval verantwoordelijk worden gesteld voor de goede werking en de levensduur van het systeem. Dit is een niet uitputtende lijst met aanbevelingen.

**PL****Nie nale y u ywa umocowanego produktu, je eli siedzenia s zło one.**

Przy monta u w бага niku nale y zadba o to, aby otaczaj ca przestrze była wolna od przeszkód, w celu unikni cia ryzyka zranienia lub uszkodzenia sprz tu. Wszelkie zmiany dotycz ce sprz tu (radio samochodowe, wzmacniacz), które mog by przyczyn zmian otoczenia, mog poci ga za sob uszkodzenie lub gorsze funkcjonowanie sprz tu, a zatem nie powinny by przeprowadzane.

CZYSZCZENIE:

W przypadku zabrudzenia pokrycie nale y wyczy ci przy pomocy suchej szmatki lub u ywaj c mydlin. Niedozwolone jest u ywanie substancji agresywnych lub ciernych.

UWAGA:

Nieprzestrzeganie powy szych zasad powoduje, e firma PSA nie ponosi adnej odpowiedzialno ci, je li chodzi o prawidłowe działanie systemu oraz czas jego eksploatacji. Lista zalece nie jest wyczerpuj ca.

**SL****Ne uporabljajte pritrjenega izdelka, kadar so sedeži spuš eni.**

Pri montaži v prtljažnik mora biti okolica pospravljena, da ne pride do poškodb predmetov ali telesne poškodbe. Vsaka menjava opreme (avtoradia, oja evalca), ki bi utegnila spremeniti okolico, lahko povzro i poškodbo ali pomanjkljivo delovanje opreme in je zato prepovedana.

IŠ ENJE:

V primeru, da je prevleka umazana, jo o istite s isto s suho krpo ali pa z milnico. Uporaba agresivnih in abrazivnih izdelkov je prepovedana.

OPOMBA:

V primeru neupoštevanja teh navodil PSA ne prevzema nobene odgovornosti glede pravičnega delovanja sistema in glede njegove življenjske dobe. Ta seznam priporo il ni iz rpen.

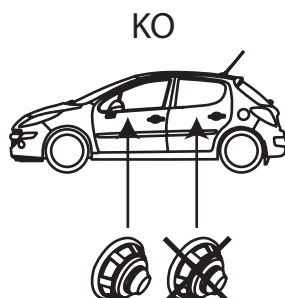
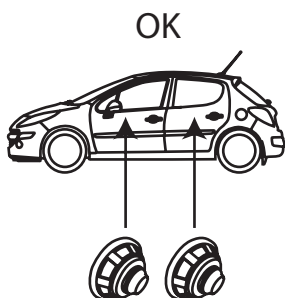
**4 Ohms**



SU

Använd inte den fasta bashögtalaren med nedfällda säten.

Vid montering i bagageutrymmet måste omgivningen vara helt fri från saker, för att undvika risker för materiella eller personsador. Alla ändringar i utrustningen (bilradio, förstärkare) som kan bidra till att ändra miljön kan skada materielen eller leda till onormal funktion och är därför inte tillåtna. Överlämna bruksanvisningen till slutkunden.

RENGÖRING:

En nedsmutsad beläggning måste rengöras med en torr tygtrasa eller tvålatten. Använd inte aggressiva medel eller medel med slipande verkan.

OBS:

Vid underlåtenhet att följa dessa föreskrifter kan PSA under inga omständigheter göras ansvarig för systemets funktion eller livslängd. Denna lista med rekommendationer är inte uttömmande.



AL

Nach dem Einbau darf das Produkt nicht bei umgeklappten Sitzen verwendet werden.

Um Beschädigungen oder Verletzungen zu vermeiden, dürfen sich beim Einbau im Kofferraum keine Gegenstände in der Umgebung befinden. Alle Änderungen an der Anlage (Autoradio, Verstärker), durch die die Umgebung verändert wird, können zur Beschädigung oder zum Ausfall des Geräts führen und sind daher zu unterlassen.

REINIGUNG:

Bei Verschmutzungen ist die äußere Oberfläche entweder mit einem trockenen Lappen oder mit Seifenlauge zu reinigen. Aggressive Reiniger oder Scheuermittel dürfen nicht verwendet werden.

HINWEIS:

Im Falle der Nichteinhaltung dieser Anweisungen lehnt PSA jede Haftung für die korrekte Funktionsfähigkeit und Lebensdauer des Systems ab. Die hier genannten Empfehlungen sind nicht erschöpfend.



TC

Nepoužívejte upevněný výrobek, pokud jsou sklopené sedačky.

Při instalaci nesmí být v zavazadlovém prostoru žádné předměty, které by mohly bránit instalaci, aby nedošlo k poškození výrobku nebo zranění uživatele. Každá změna na komponentech hudební sestavy (autorádio, zesilovač) může změnit vlastnosti prostředí a způsobit poškození nebo dysfunkci těchto komponentů, a je tudíž žádoucí se jí vyhnout.

IŠT NÍ:

Pokud dojde ke znečištění, vyistete povrch výrobku suchým hadrem nebo ho omyjte mýdlovou vodou. Vyvarujte se agresivních a abrazivních čistících přípravků.

POZNÁMKA:

PSA nenesie odpovednosť za žiadne fungovanie systému a jeho životnosť pri nedodržení uvedených pokynov. Tento zoznam odporúčení není úplný.

OK

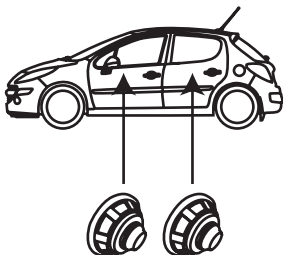

KO

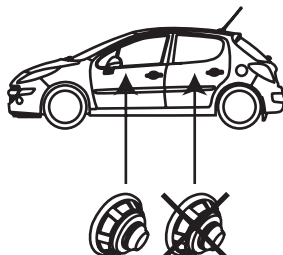

4 Ohms

