



ACT. 697

A USAGE PROFESSIONNEL / FOR PROFESSIONAL USE / MONTAGE DURCH FACH PERSONAL / VOOR PROFESSIONEEL / PARA USO PROFESIONAL / PARA USO PROFISSINAL / AD USO PROFESIONALE / DO UZYTKU PROFESJONALNEGO.



- C2.....P4
- C3.....P5
- C3 Pluriel.....P6
- C3 Picasso.....P7-P8
- C3 (A51)P9-P10
- Ds3.....P11P12
- C4 Coupé.....P13
- C4 5p.....P14
- C4 Picasso.....P15-P16
- C4 Grand Picasso.....P17
- C5 III.....P18-P19
- C5 III Tourer.....P20-P21
- C6.....P22-P23
- C Crosser.....P24-P25
- Nemo.....P26

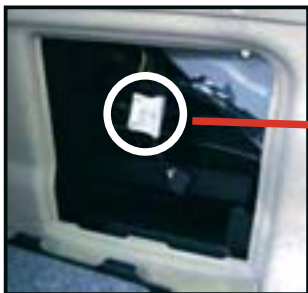
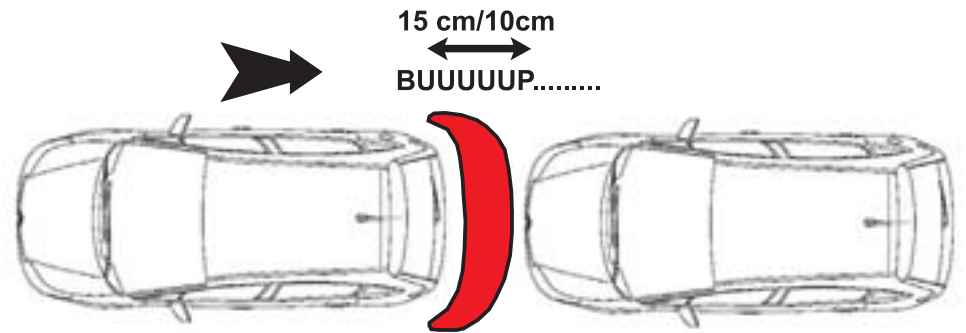
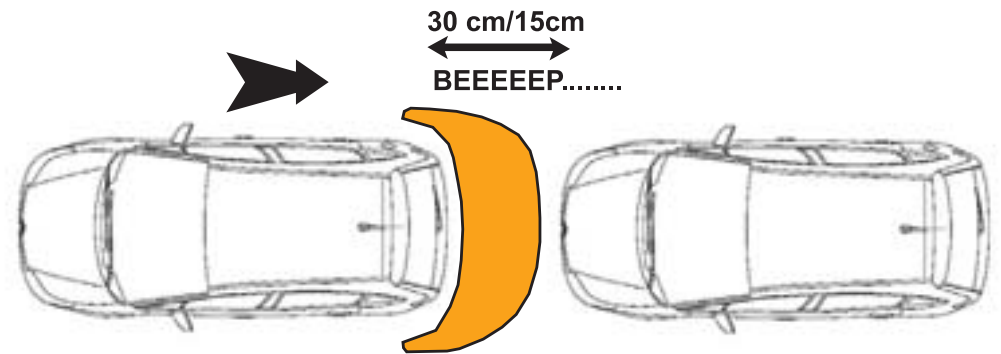
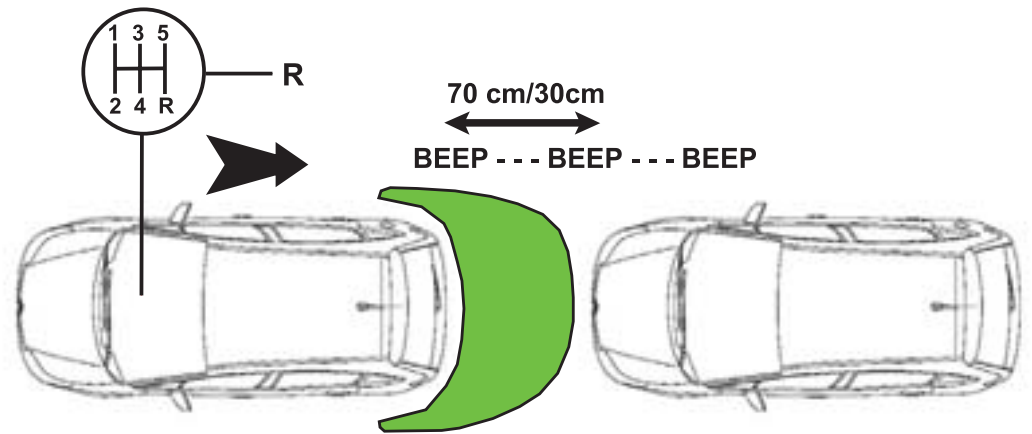

Réf: 9452.71 = OK

F Le module ne doit être installé que sur des véhicules avec pare-chocs en plastique. Pour un résultat optimum, installer le module éloigné du métal (4 cm minimum) et respecter le positionnement préconisé de l'antenne le plus haut possible dans le pare-chocs.

GB The parking aid modul has to be installed on vehicles with plastic bumpers only. To obtain the best result, do not install the module nearby metal , keep a distance of 4cm minimum and try to establish the antenna as high as possible in the bumpers.

SP El descubridor debe instalarse solamente en vehículos equipados de parachoques en plástico.

Para un funcionamiento óptimo, el módulo debe ser instalado con distancia del metal (4 cm minimos), y implantar la antena lo más alto posible en el parachoques.

P O módulo deve ser instalado únicamente em veículos equipados de para-chóques em plástico.

Para um resultado óptimo, instalar o módulo afastado do metal (4 cm mínimo) e implantar a antena o mais alto possível no para-chóques.

D Das Parkmodul darf nur eingebaut werden in Fahrzeuge mit Kunststoff Stoßstangen. Um ein Optimales Resultat zu bekommen , soll man das Modul so weit wie möglich entfernt von Metal einbauen (minimum 4 Cm) und die Antenne soll man so hoch wie möglich in die Stoßstange einbauen.

I Il modulo non deve stare installare che sopra gli veicolo con paraurti da plastico. Per uno risultato massino, installare il modulo allon tanare il metallo (4 cm minimo) e impiantare l'antenna il piu alto possibile in paraurti.

NL De parking module moet ingebouwd worden in voertuigen voorzien met kunststofbumpers. Om een optimaal resultaat te bekomen moet de module verwijderd van enig metaal (minimum 4 cm) geïnstalleerd worden en de antenne moet vervolgens zo hoog mogelijk in de bumper ingebouwd worden.

PL Modul moze byc instalowany tylko w pojazdach posiadających plastikowe zderzaki. W celu uzyskania optymalnych rezultatow, modul nalezy zainstalowa z dala od czesci metalowych (minimum 4 cm), a anten umiescic jak najwyzej, w zderzaku.

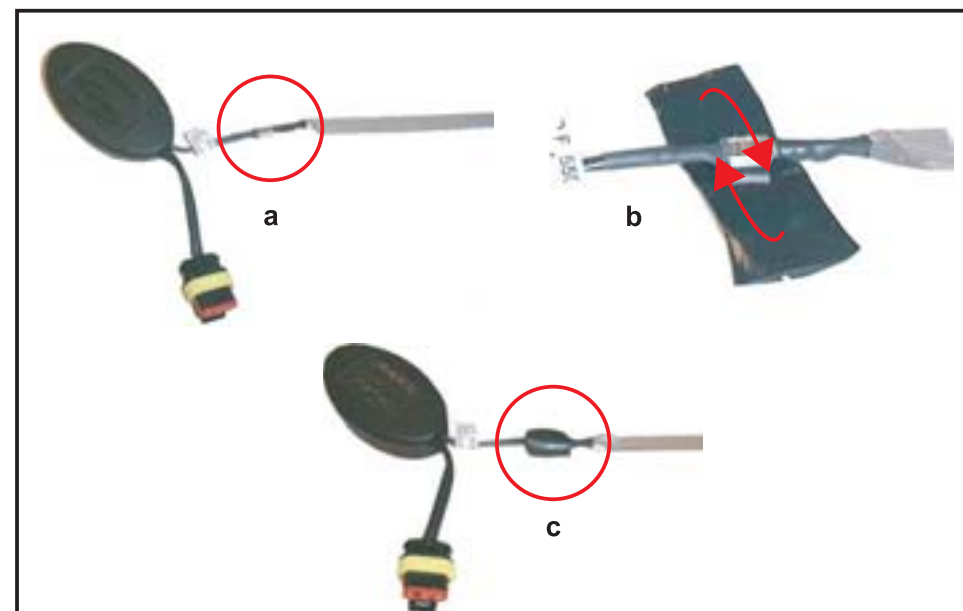
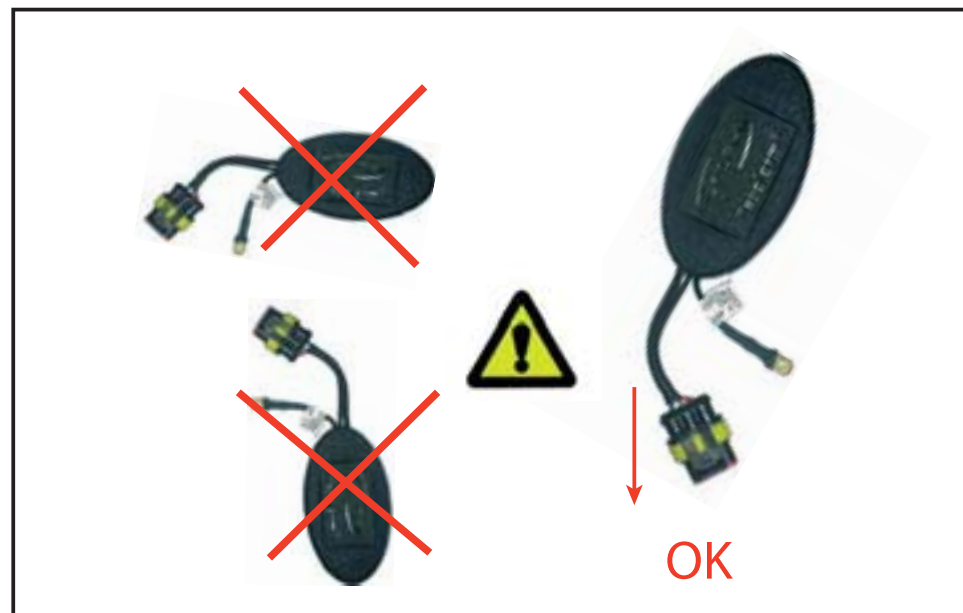



C2

Réf: 9452.71



a

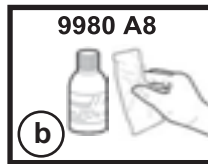
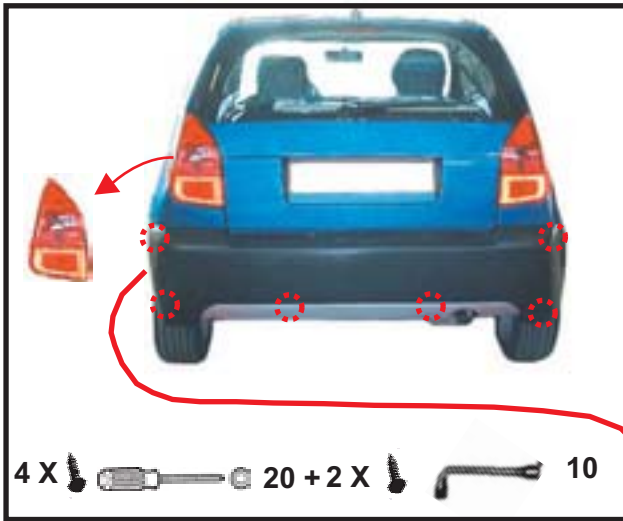

4 X 20 + 2 X 10

c

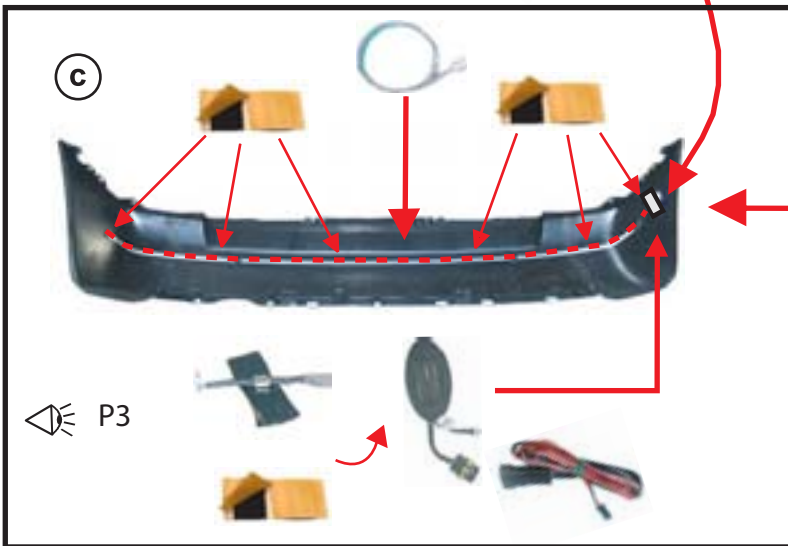

P3

d



e

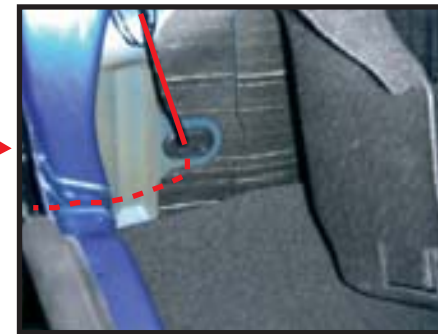

f

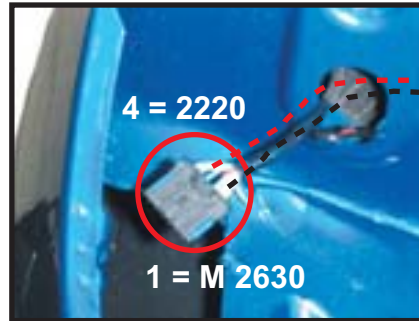

2 X
RAYCHEM ZCP
830 390 A

g

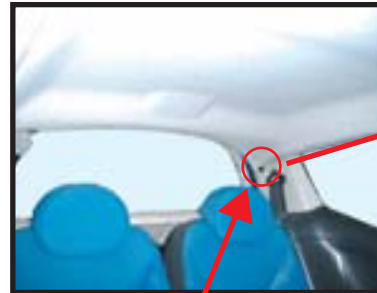

h







P4



C3

Réf: 9452.71

1.80 H

- 4 X 
- 4 X   10
- 2 X 
- 2 X 



Citröen service

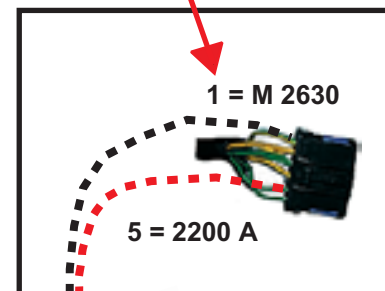
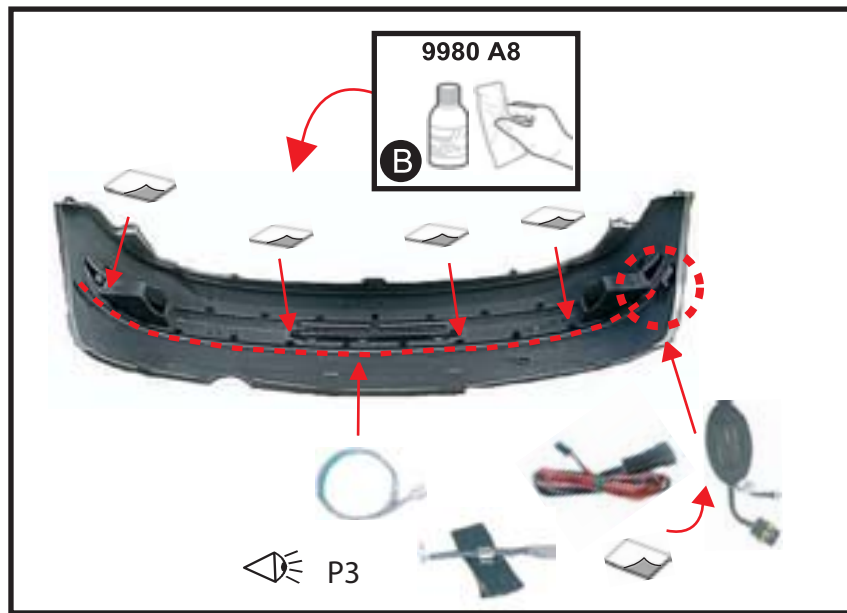

2 X 
 RAYCHEM ZCP
 830 390 A

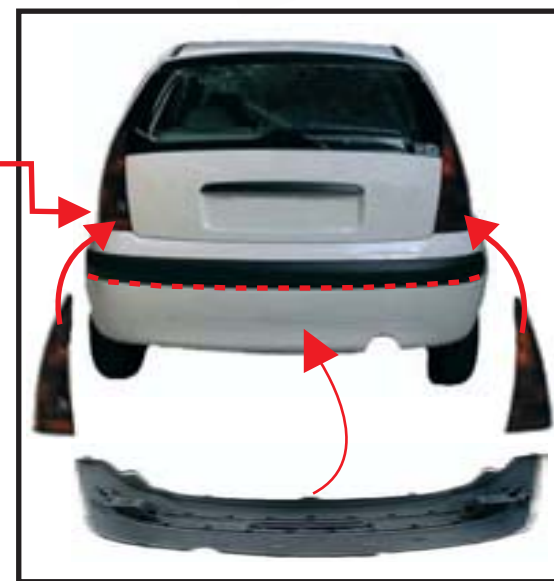

P5

 **CITROËN**



C3 PLURIEL

Réf: 9452.71

 **1.80 H**

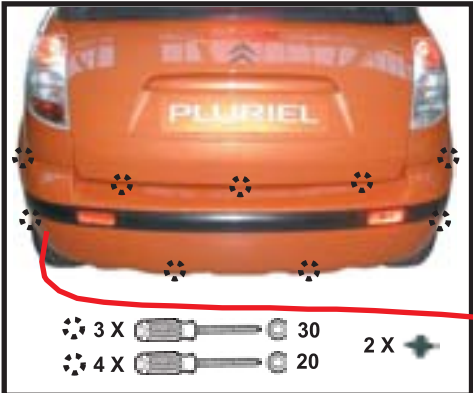
a





  Citroën service

9980 A8

B



3 X  30
 4 X  20 2 X 

c

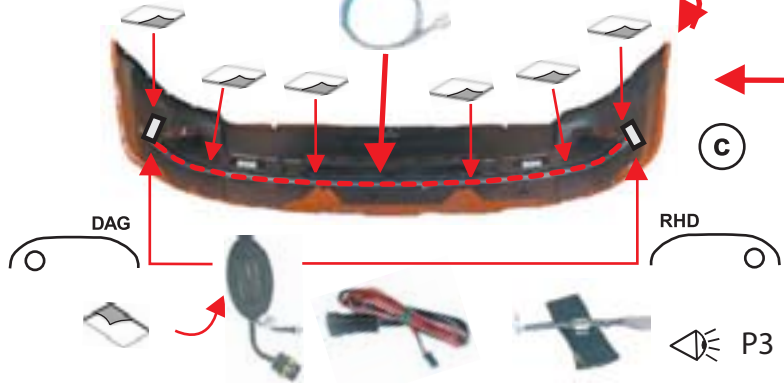

DAG RHD

 P3

d

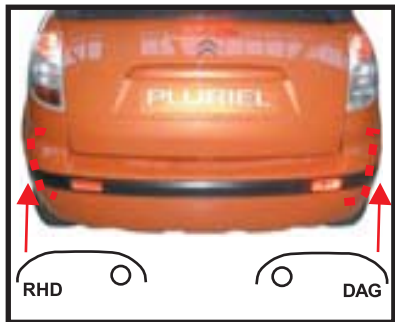

RHD DAG



e

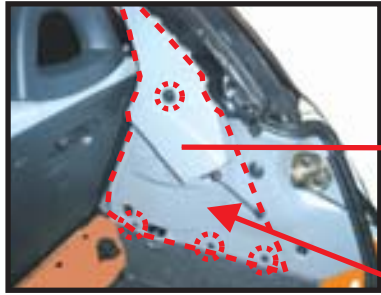

4 X  20

f

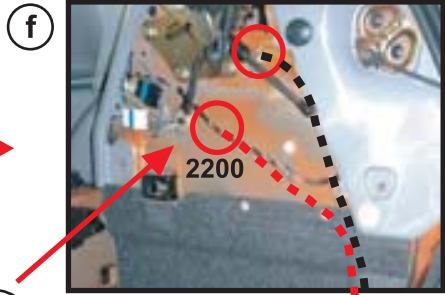

2200

DAG

1 X  RAYCHEM ZCP 830 390 A

g

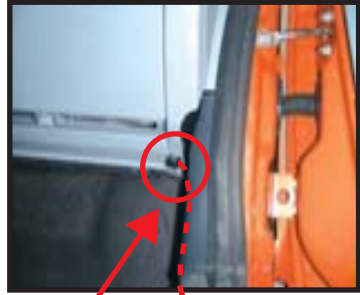

h



4 X  RAYCHEM ZCP 830 390 A

P6





C3 Picasso



Réf: 9452.71

ACT 1625

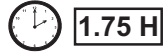

TX 20/30



10



2 x Raychem
830 390 A



1

A



Citroën
service



a

b



□ = 2 x

○ = 2

d



B



2 x

2 x

3 x

3 x

2 x



9980 A8

C

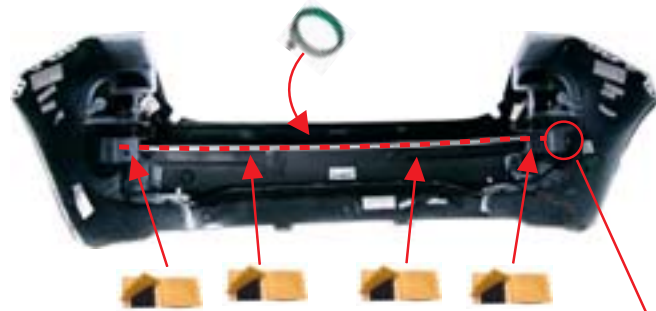

P3

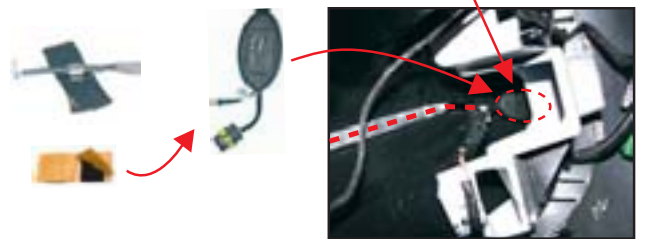

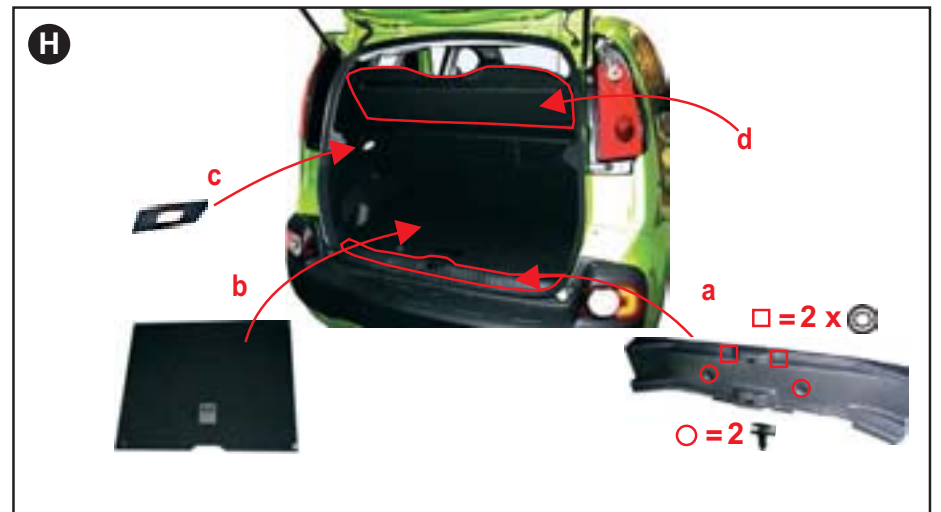
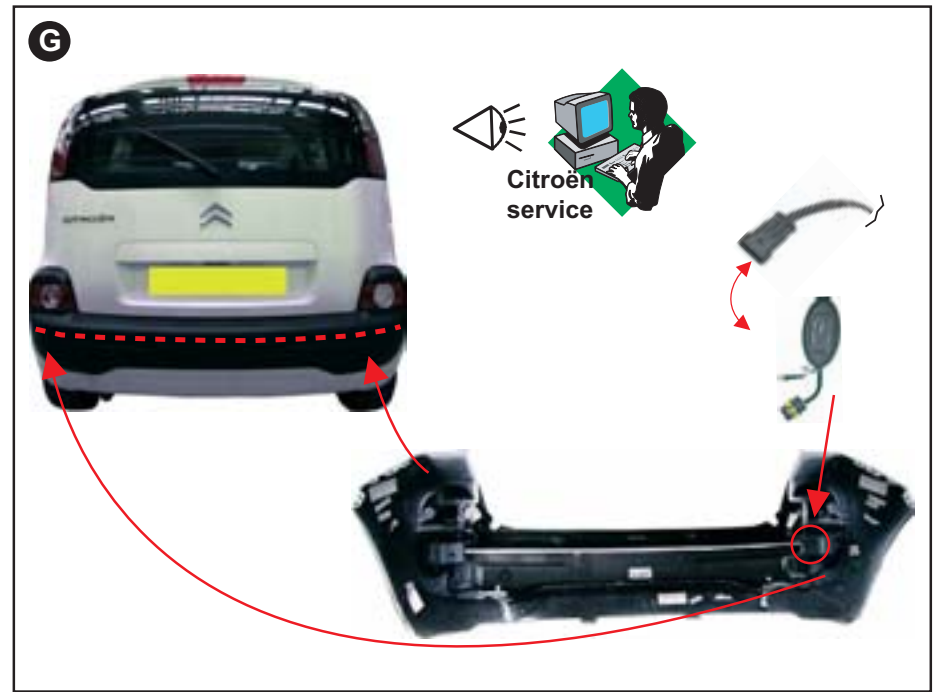
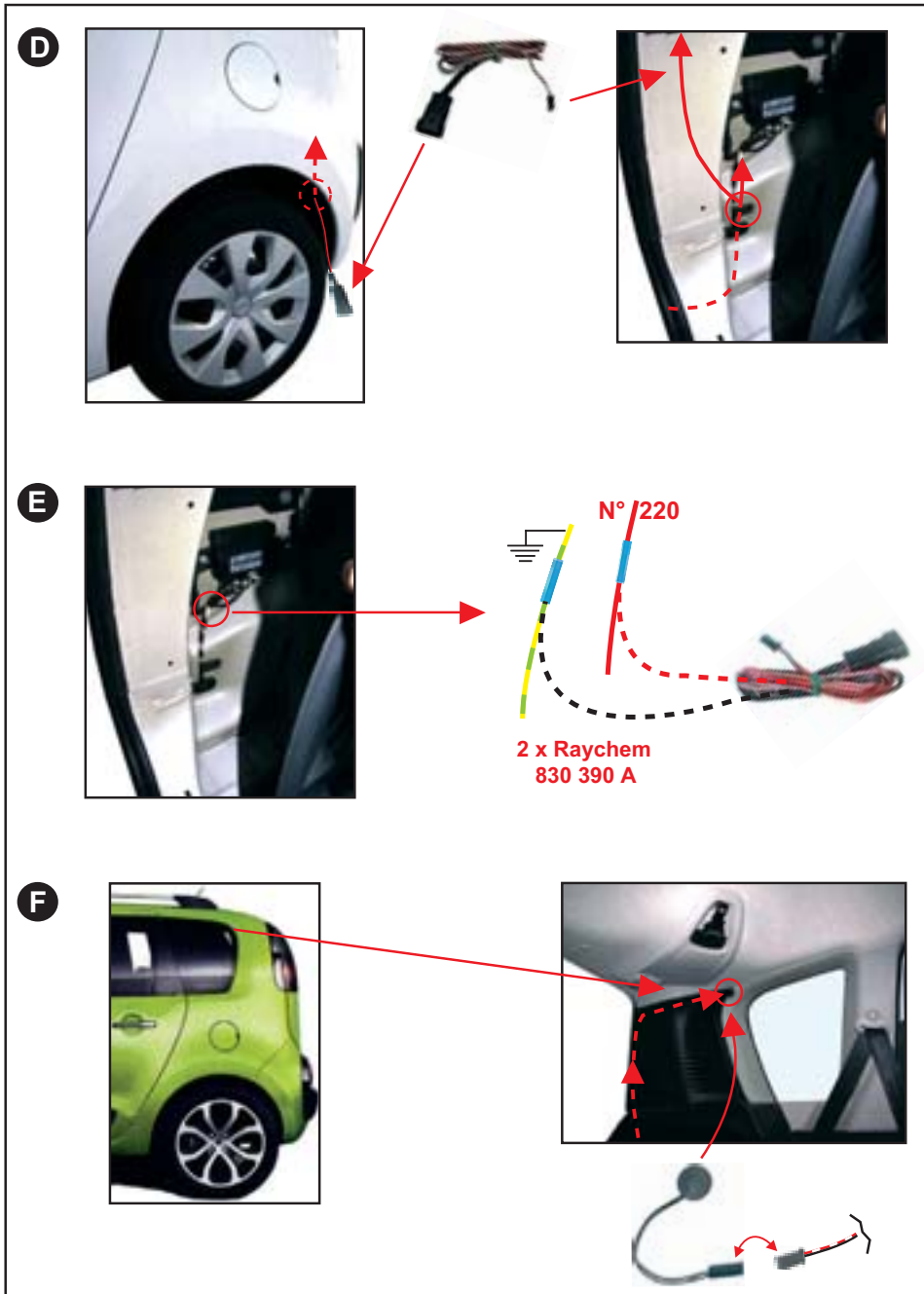



CITROËN
ACT 1692

C3 (A51)



Réf: 9452.71



1.75 H



①



10





2 x Raychem
830 390 A

A



Citroën
service



a

b

1 x

2 x



2 x

B



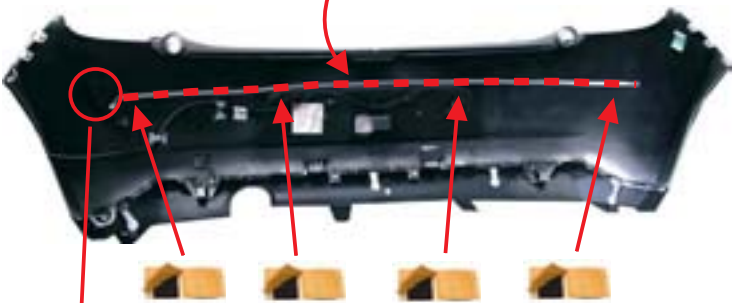

9980 A8

C



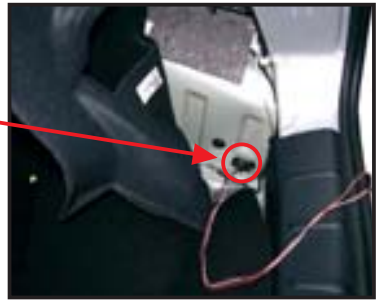

P3

D

P9

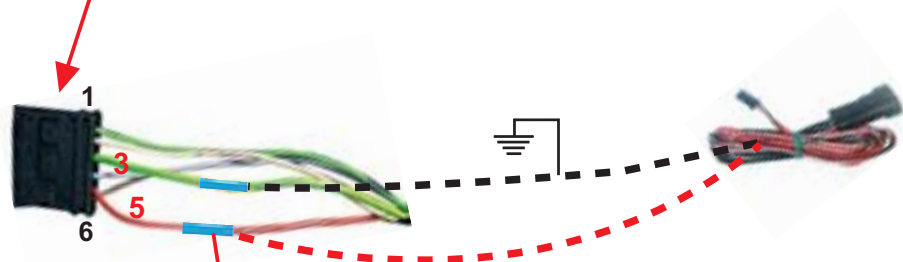
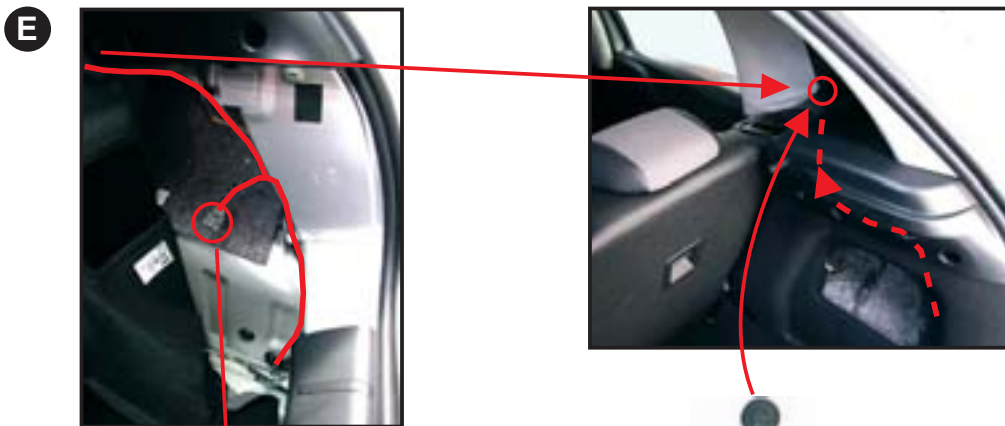

2 x Raychem
830 390 A

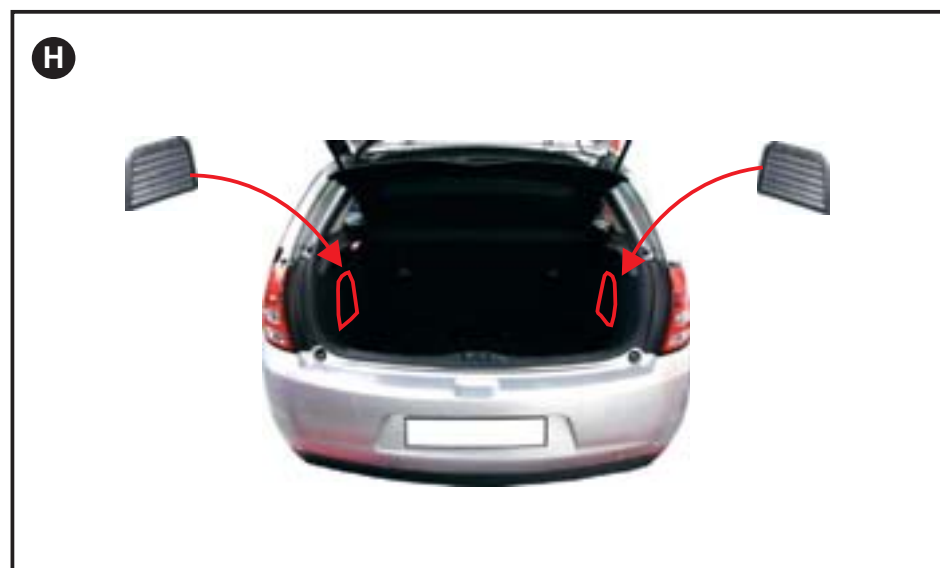
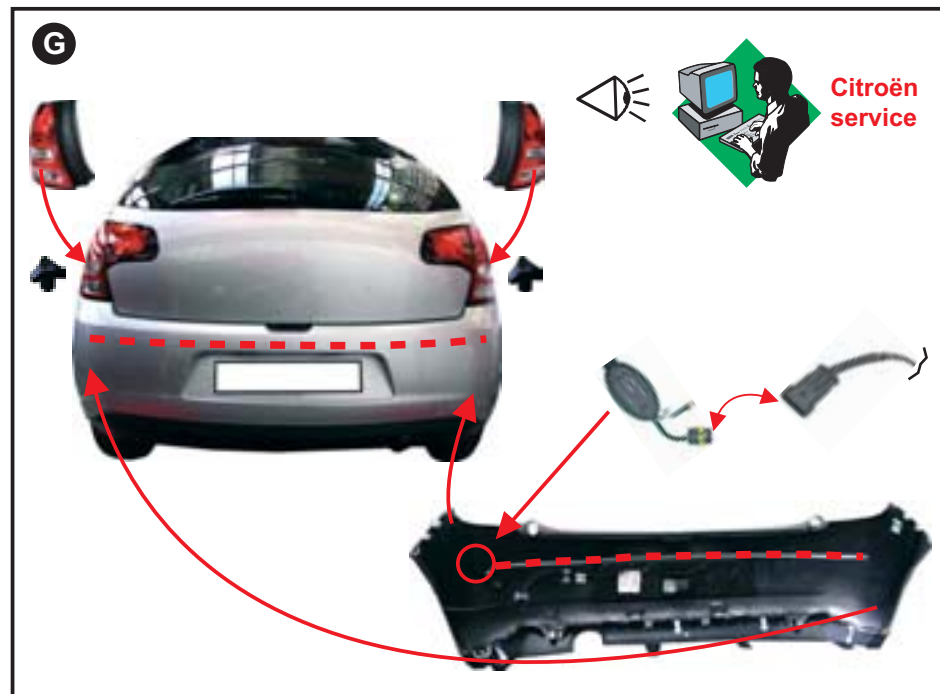

P10



CITROËN
ACT 1724



Réf: 9452.71





1.75 H

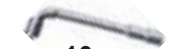

①



10

2 x Raychem
830 390 A

A



Citroën
service



a

b

1 x

1 x

2 x

2 x

B



9980 A8

C

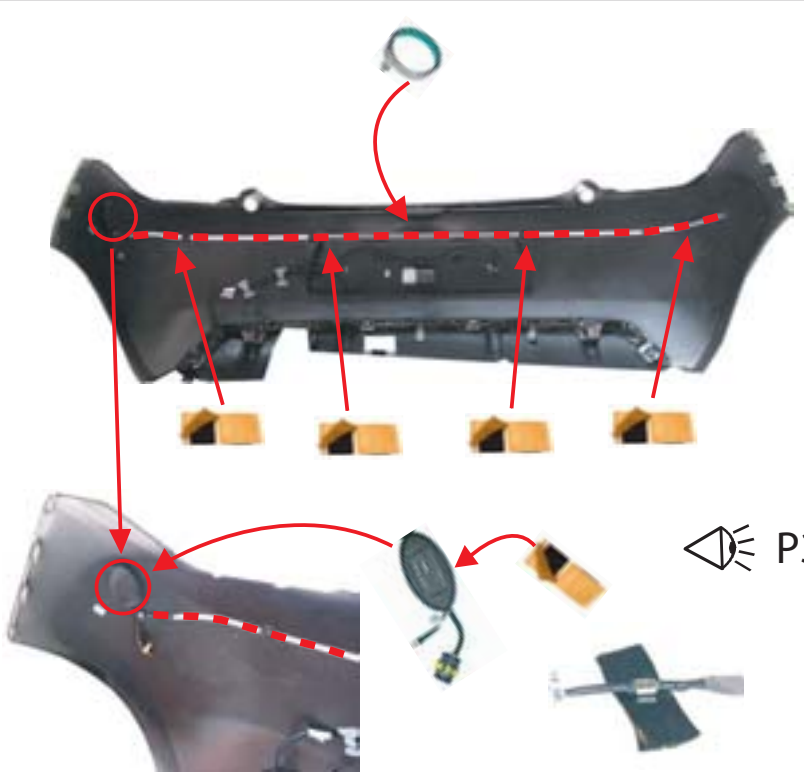



P3

D

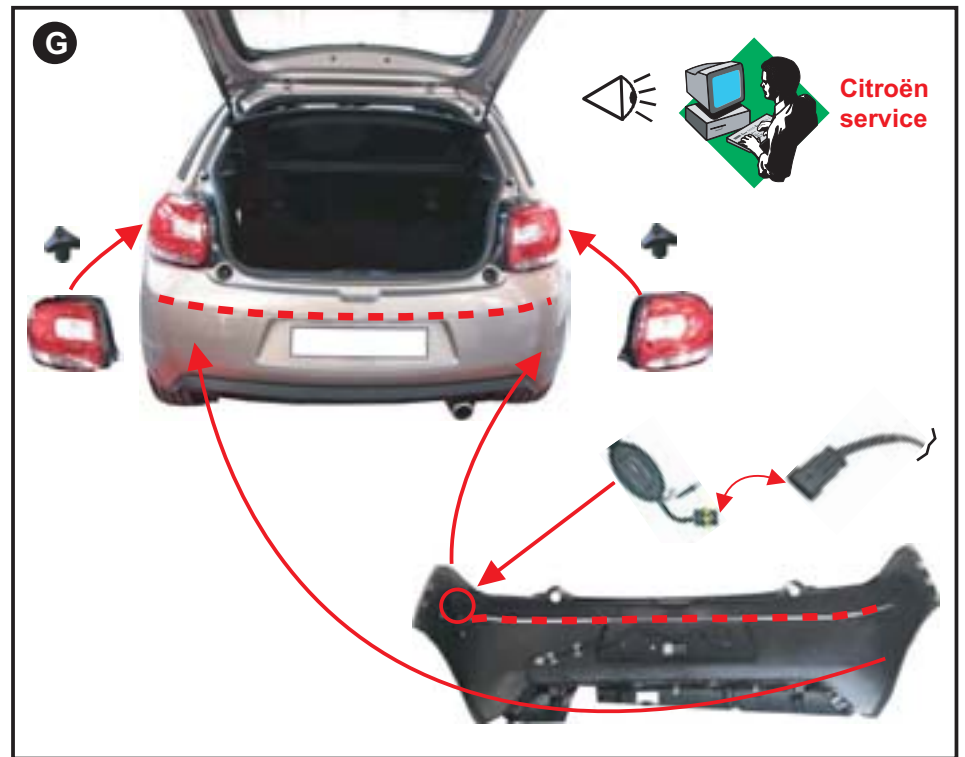
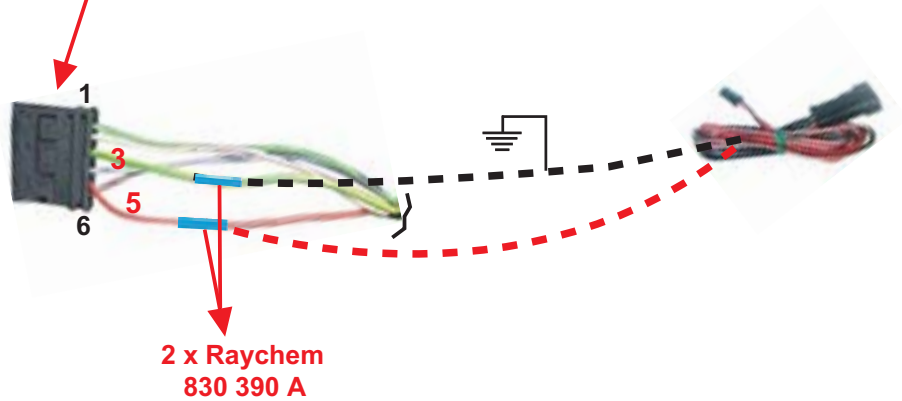
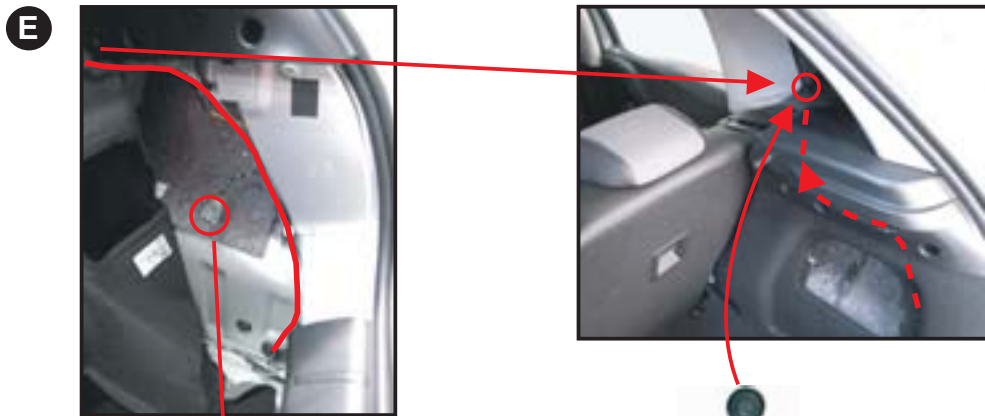





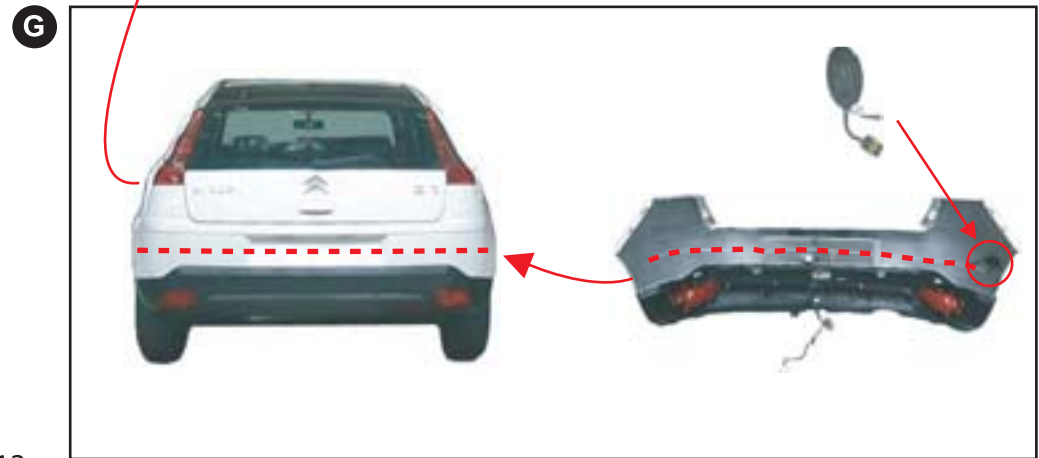
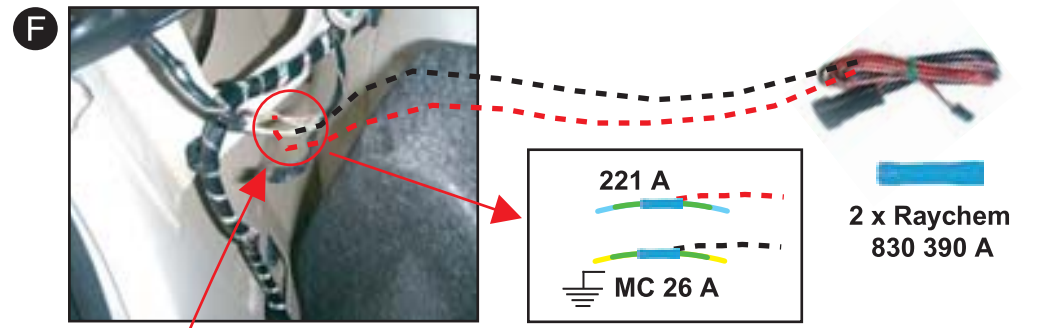
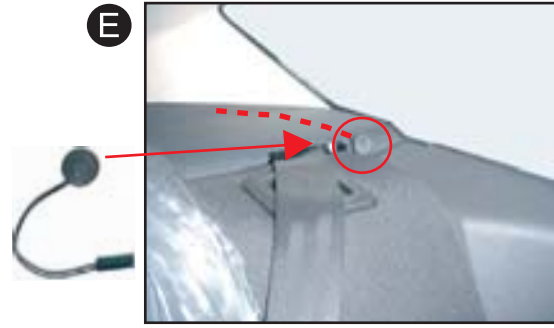
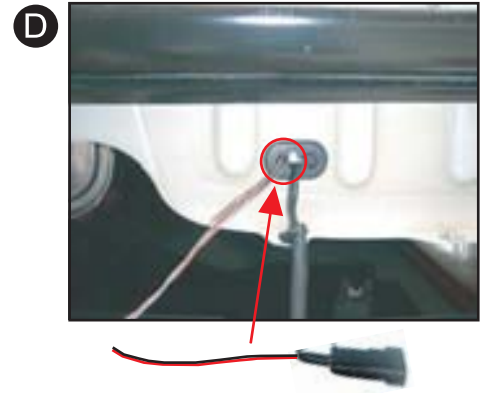
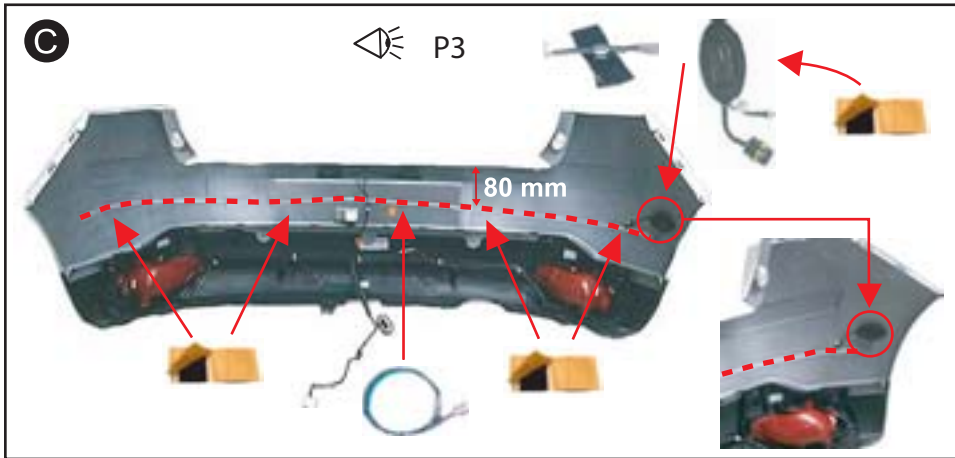
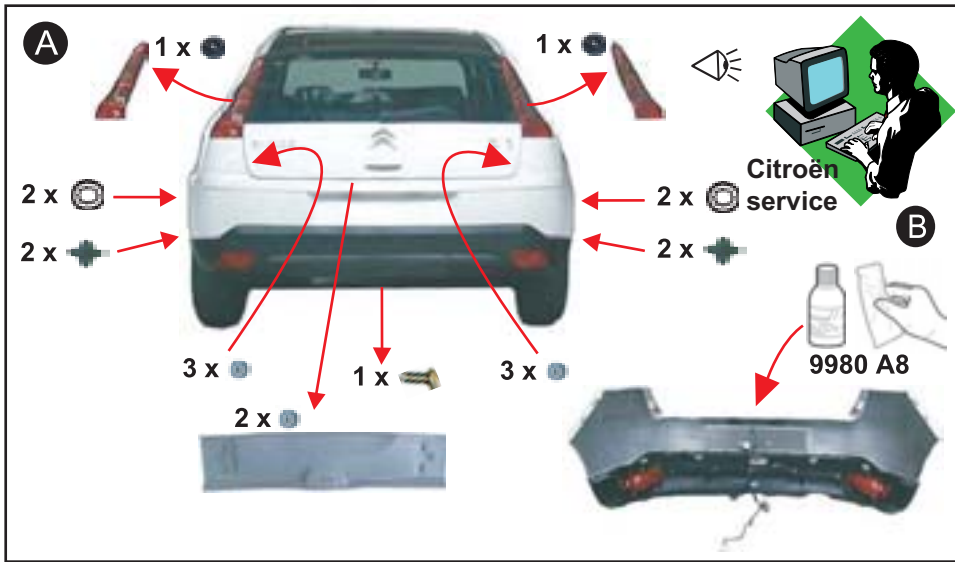

CITROËN **C4 Coupé**  Réf: 9452.71

 **2 H 00**

-    10
-  2 x Raychem 830 390 A





 **C4 5/Portes**  Réf: 9452.71

 **2 H 00**

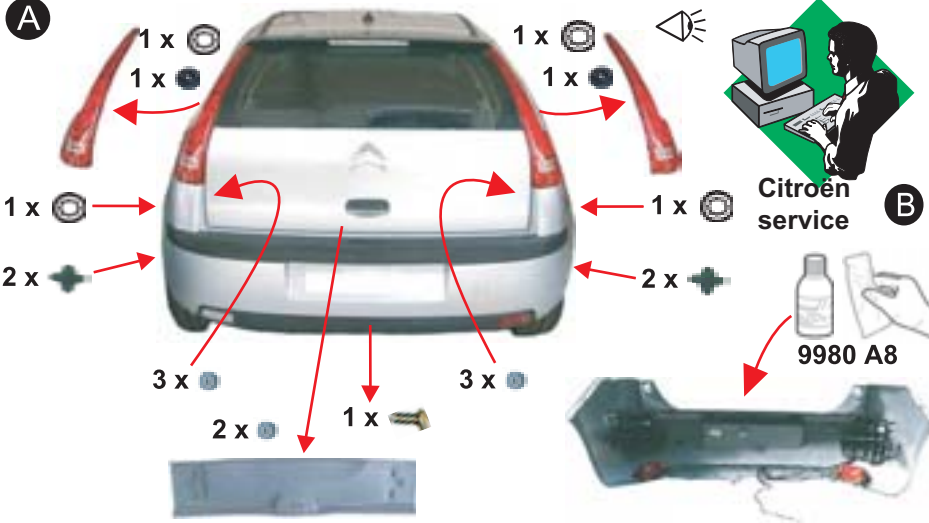
 **T 20**
T 30  **10**  **2 x Raychem 830 390 A**

A 

B  **Citroën service**

 **9980 A8**

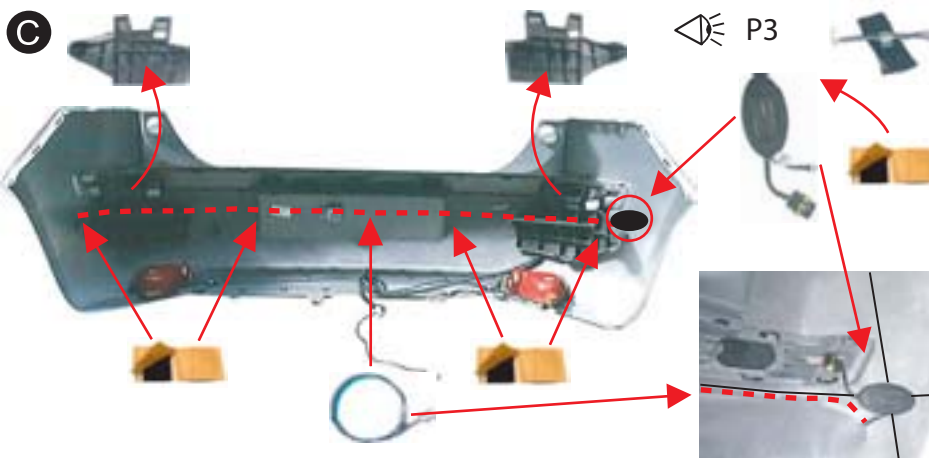
C 

P3

D 

E 

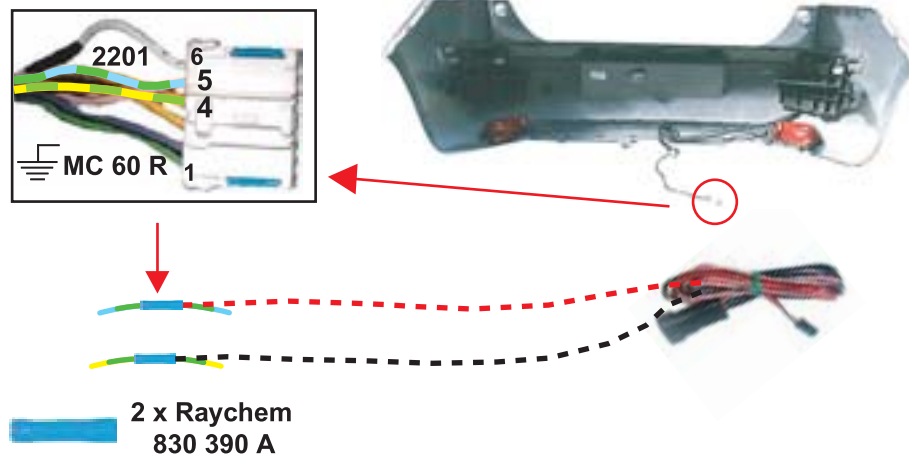

F 

2 x Raychem 830 390 A



G 





 **C4 Picasso**  Réf: 9452.71

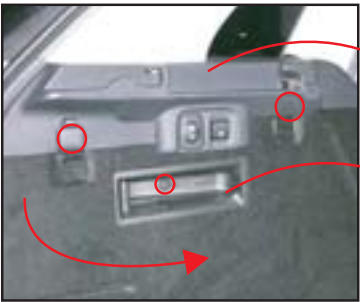

 **2 H 00**

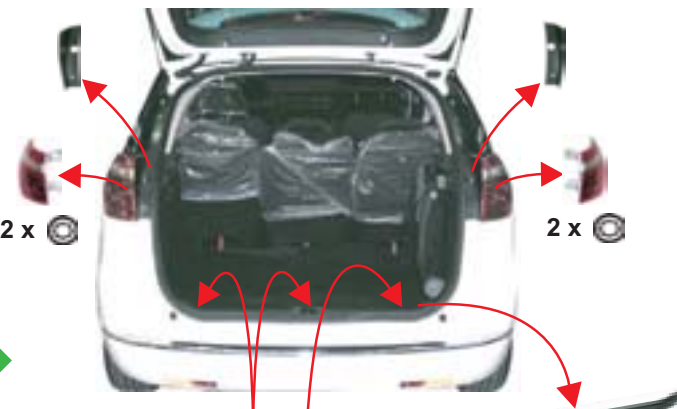





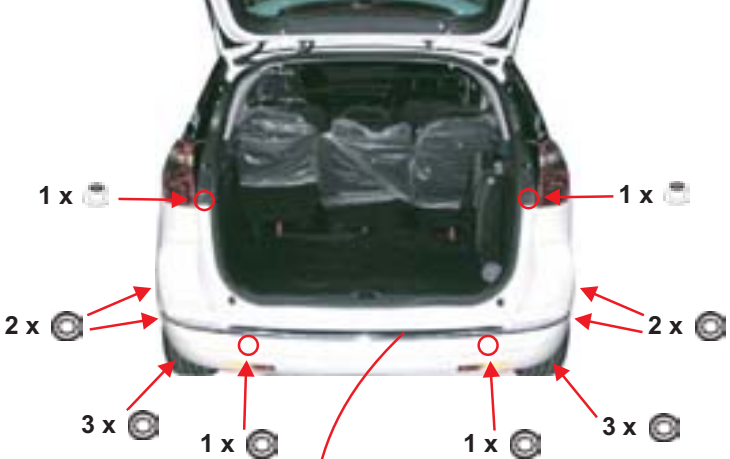

 **T 20/30**  **10** 

 **1** **2 x Raychem 830 390 A**



A  **3 x** 

B  **2 x**  **2 x**  **3 x** 

  **Citroën service**

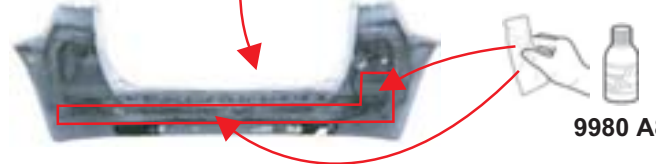
C  **1 x**  **1 x**  **2 x**  **2 x**  **3 x**  **1 x**  **1 x**  **3 x** 

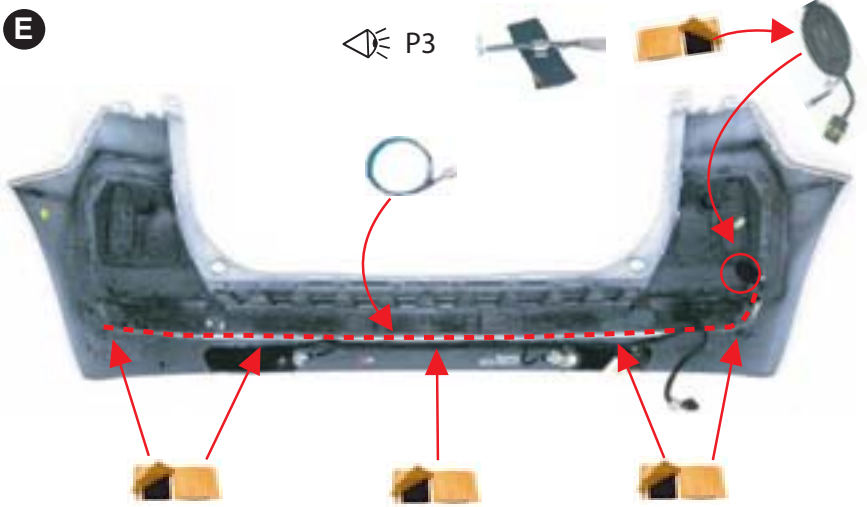
D  **9980 A8**

E  **P3** 

F

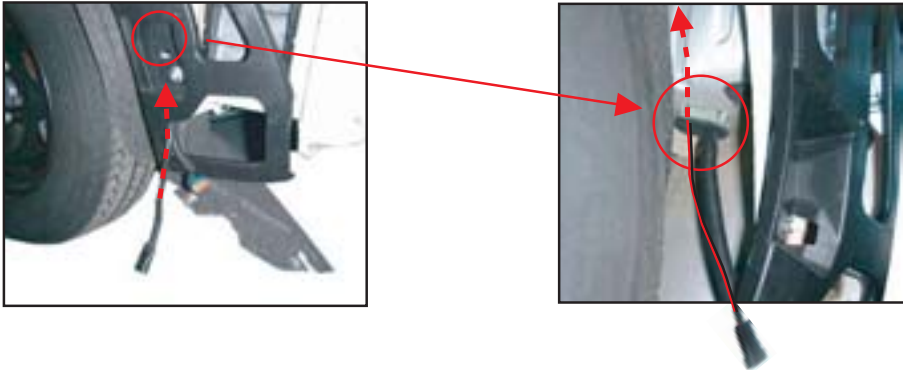

H

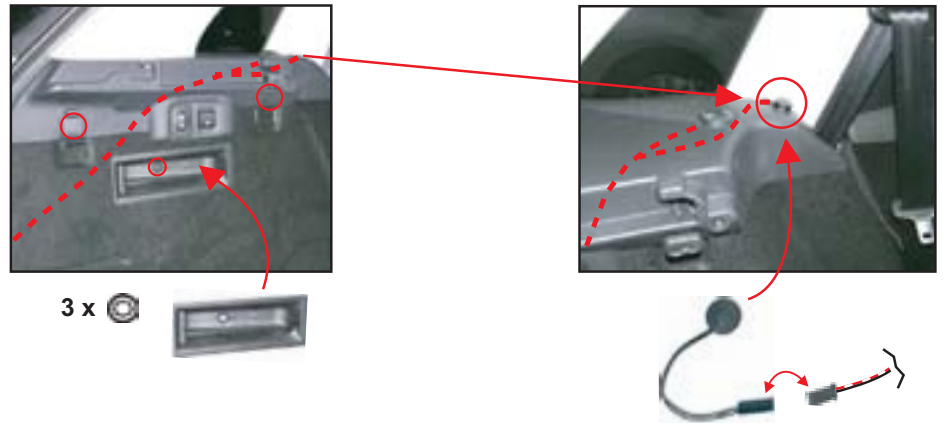

G

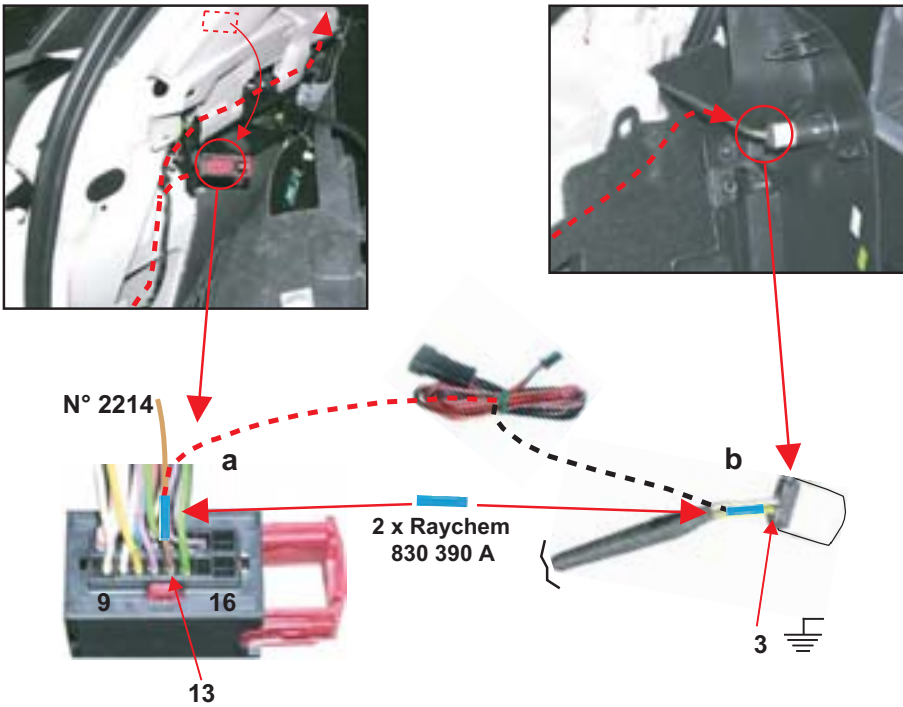



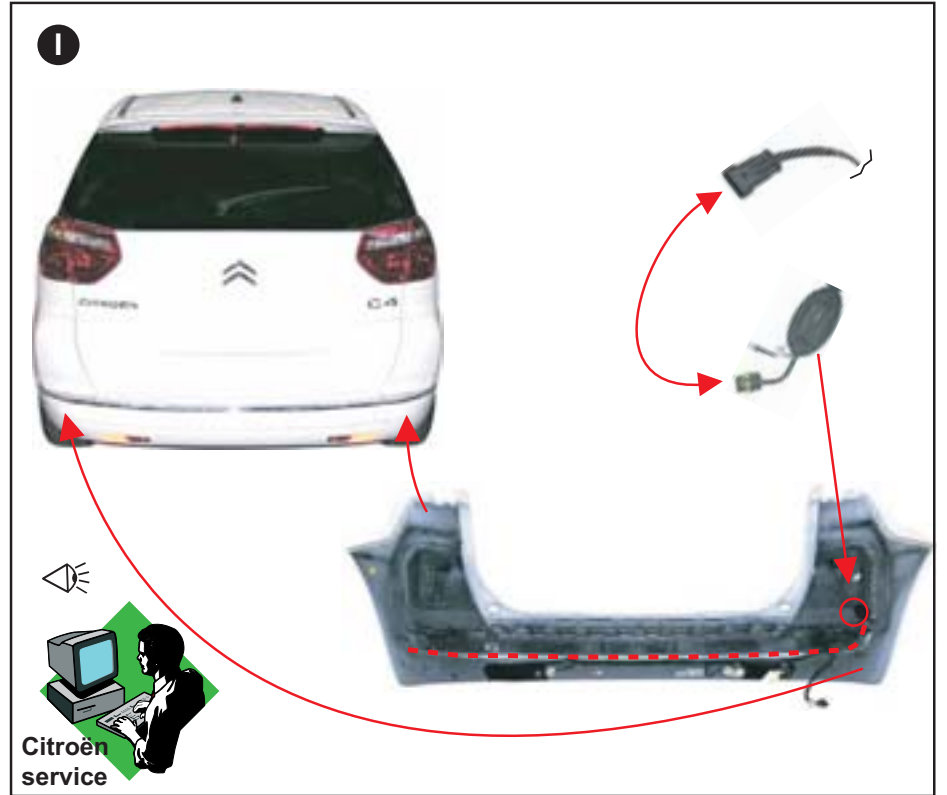

I







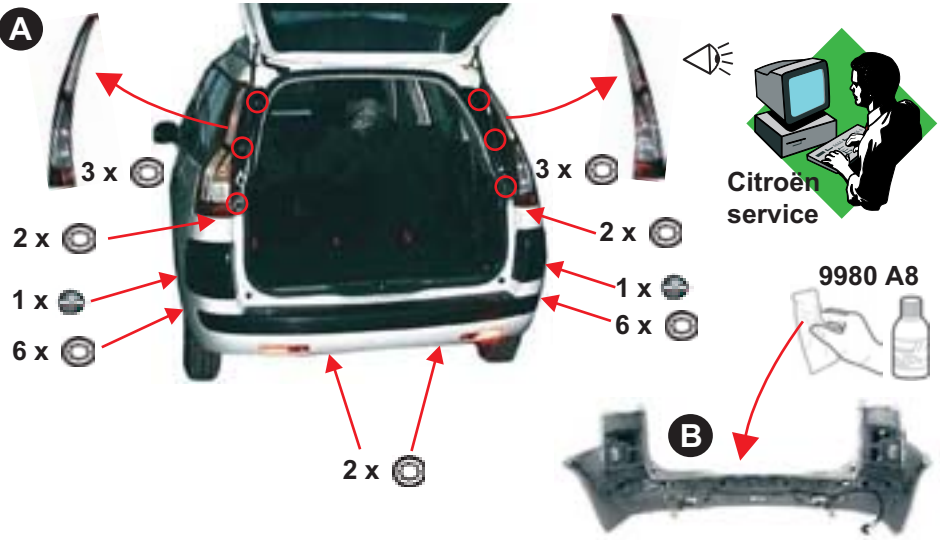



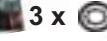

 **GRAND C4 PICASSO**  Réf: 9452.71

 2 H 00



 20/30  ① 2 x Raychem 830 390 A



A    Citroën service

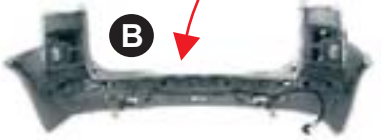

3 x  2 x  1 x  6 x  2 x 

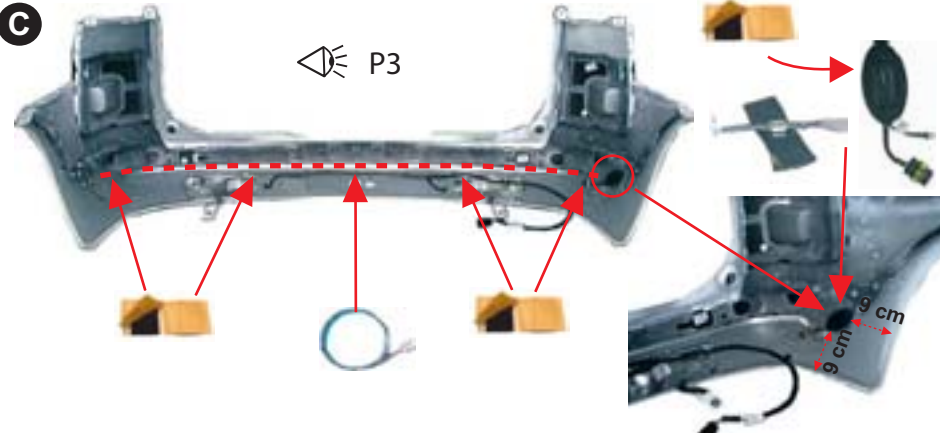

3 x  2 x  1 x  6 x  2 x 

B 

9980 A8  

C   P3

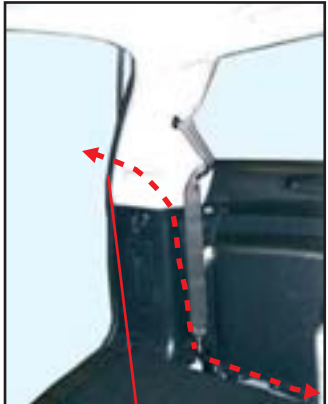
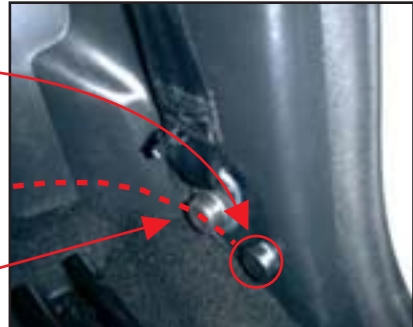

9 cm  9 cm 

D  

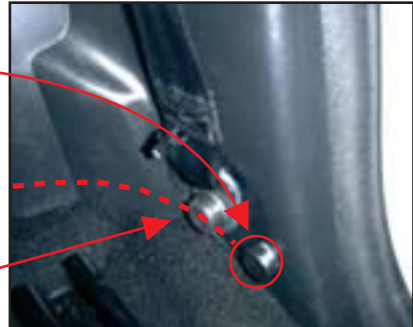
E  

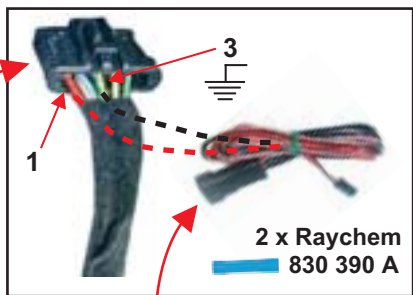
F 

G  

3  1 

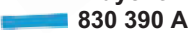
2 x Raychem 830 390 A 

H  



C5 III



Réf: 9452.71

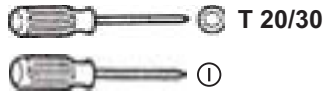

10



1m50

3 x Raychem 830 390 A

A



B

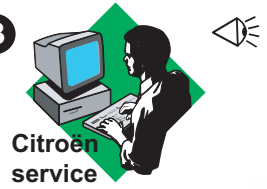

Citroën service



C



D

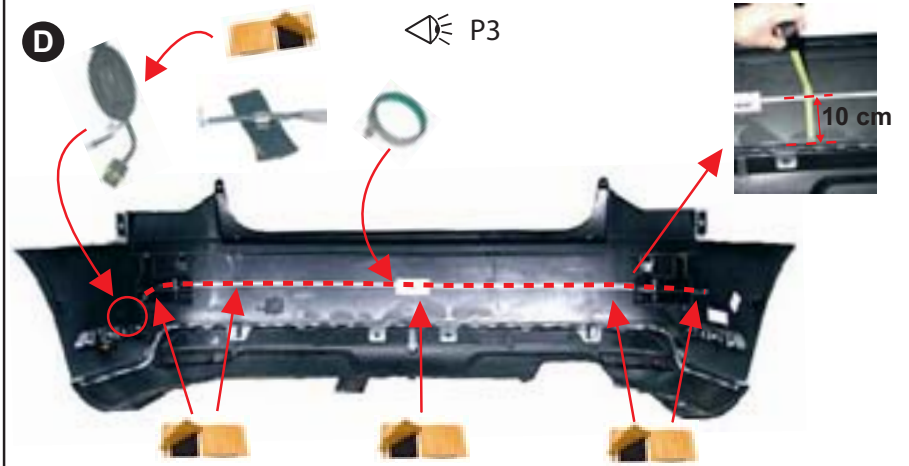

E

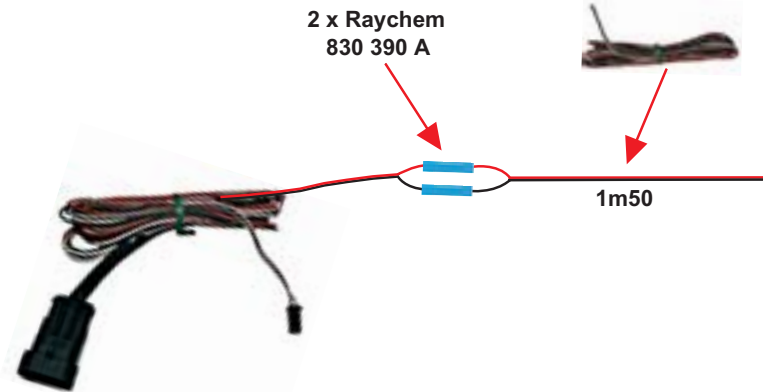

F

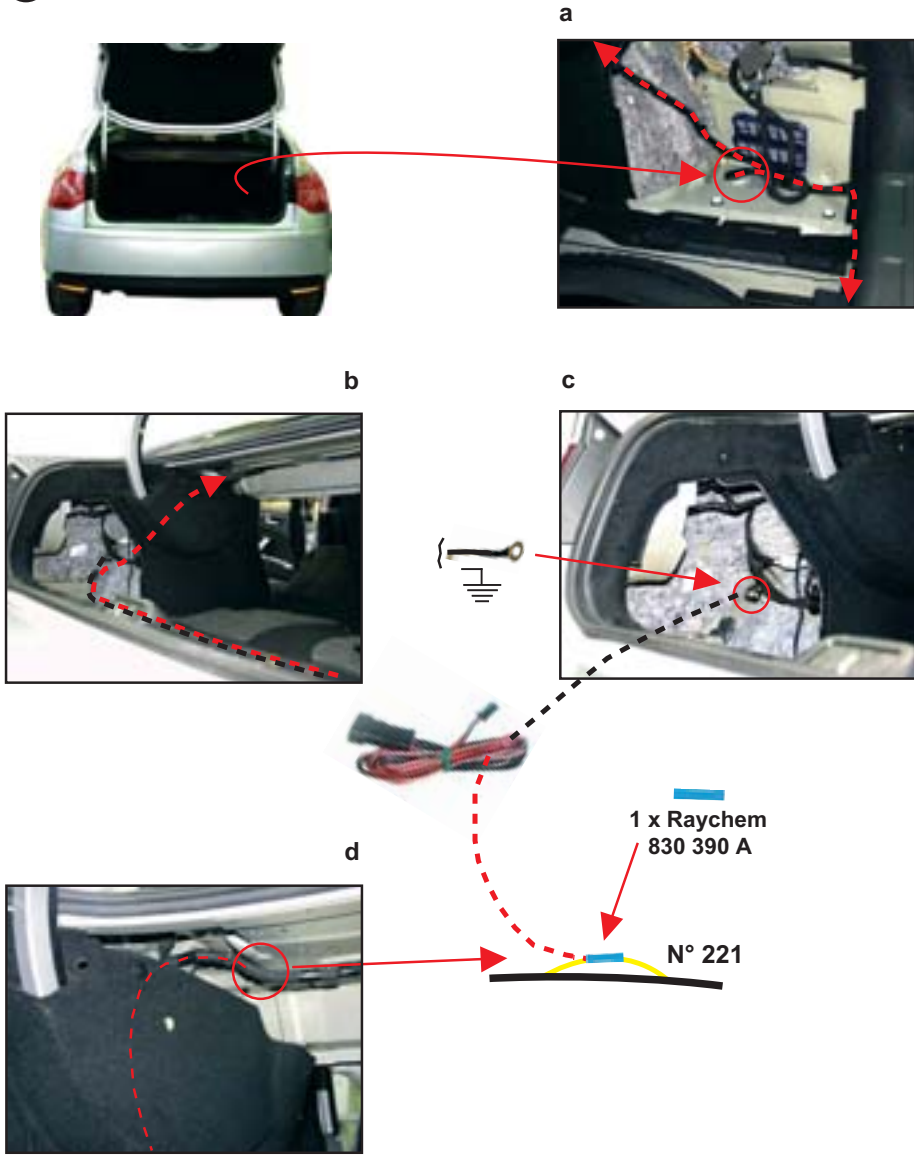

G



H





CITROËN
ACT: 1519

C5 III



Réf: 9452.71



1.50 H





T 20/30

10

1m50

2 x Raychem 830 390 A





Réf: 9452.71
OK



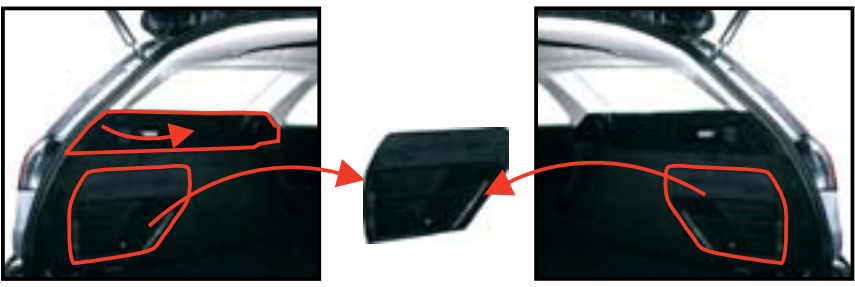

~~**Réf: 9452.71**~~

A



B

2 x

1 x

2 x

1 x

2 x

1 x

C

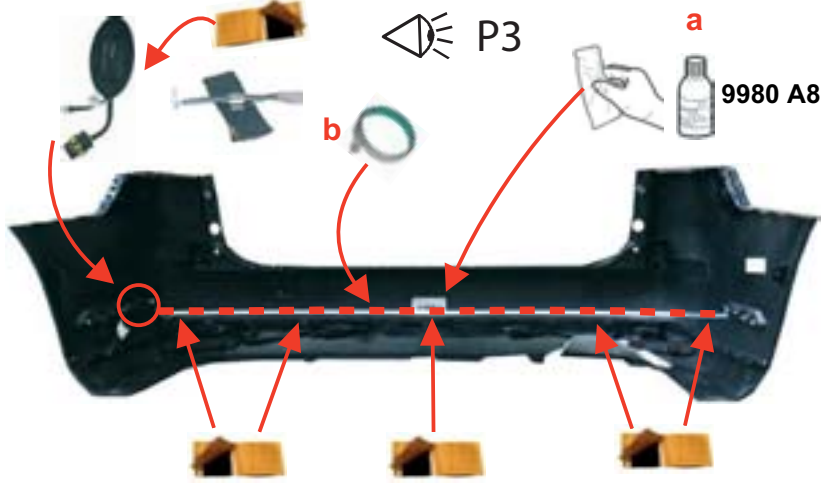

P3

a

9980 A8

b

D

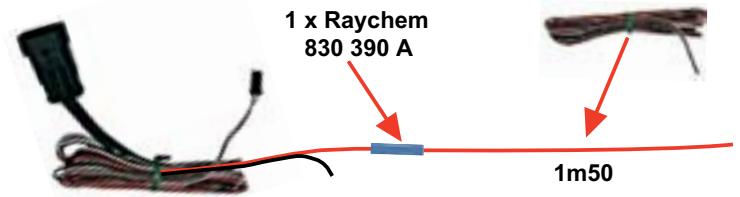

1 x Raychem 830 390 A

1m50

E

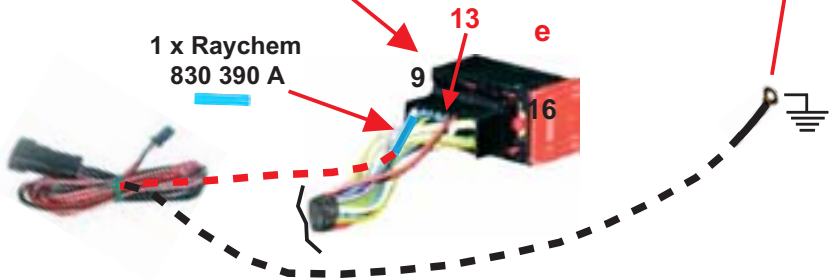
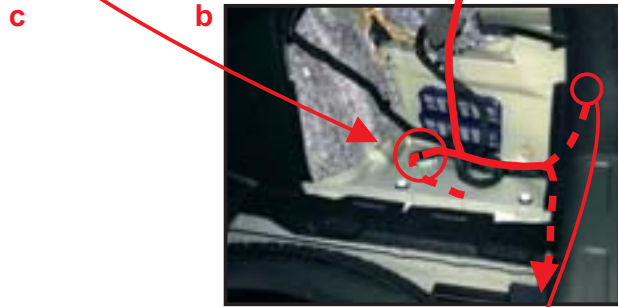

1 x Raychem
830 390 A

F

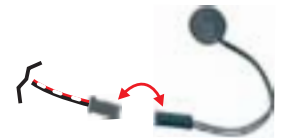
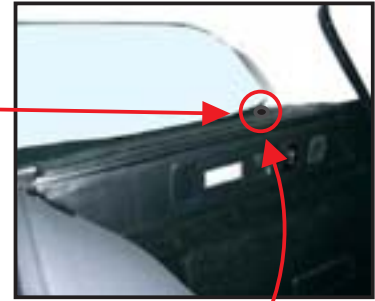

G

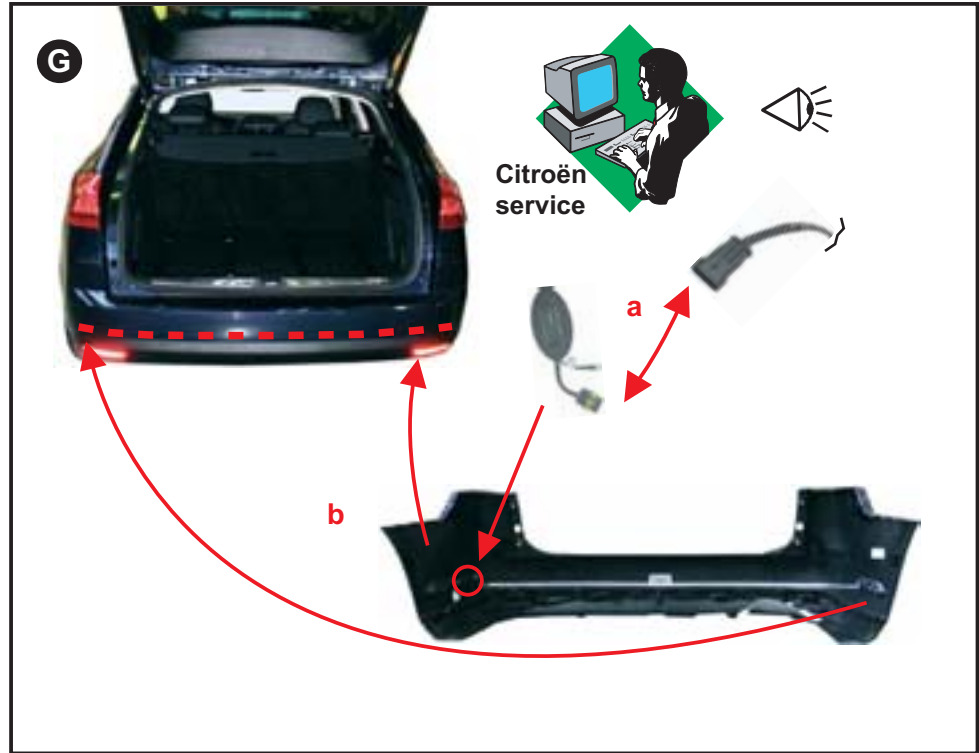

P21

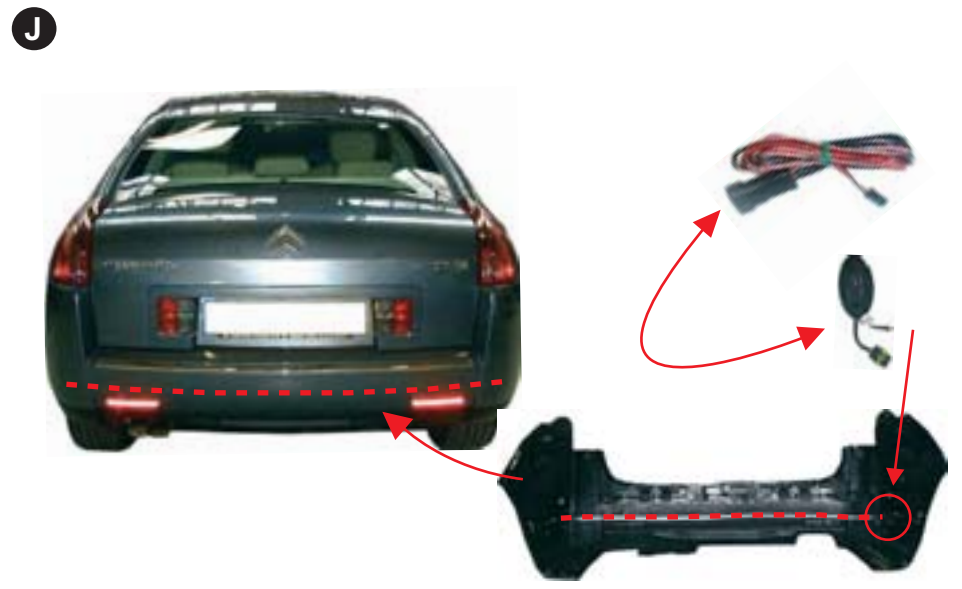
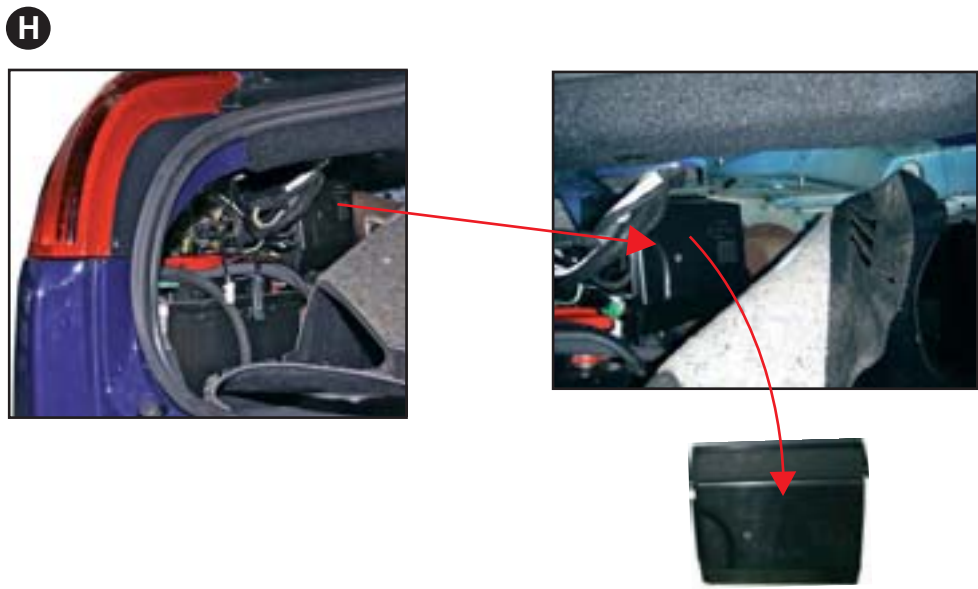
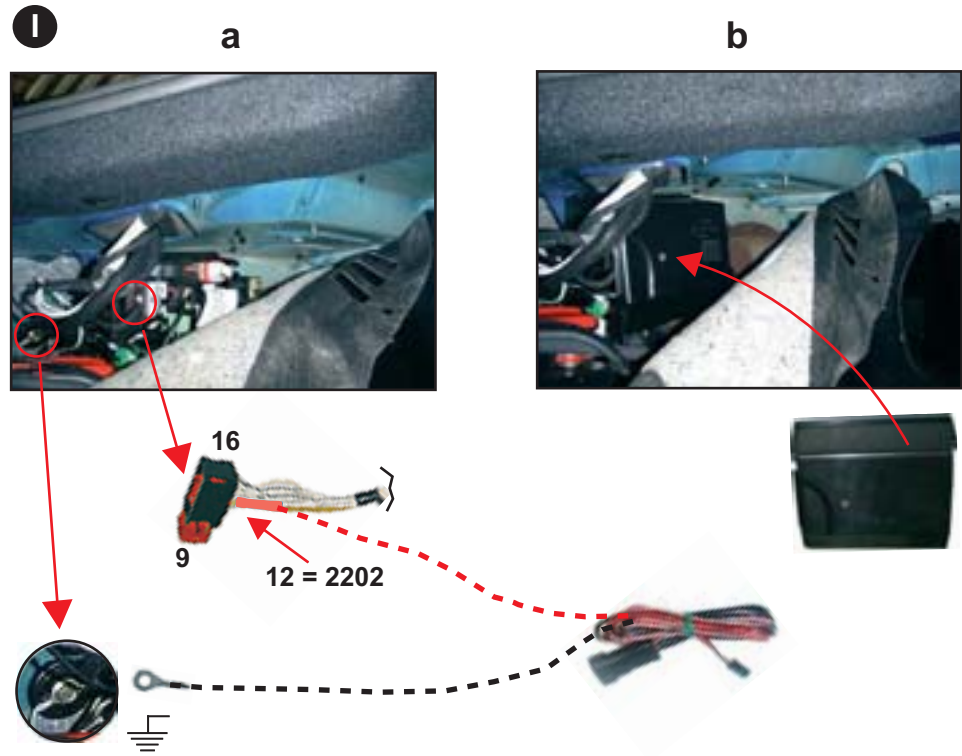
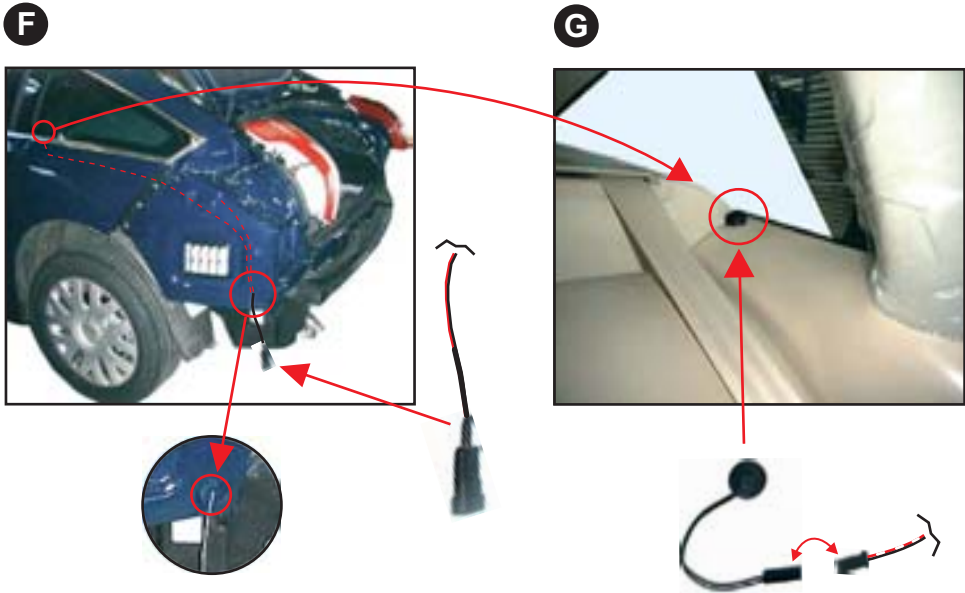



C Crosser



Réf: 9452.71
ACT 697

1.70 H

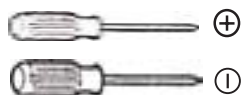

2 x Raychem
830 390 A

A



Citroën
service



2 x ⊕



2 x ⊕



2 x ●

2 x ●

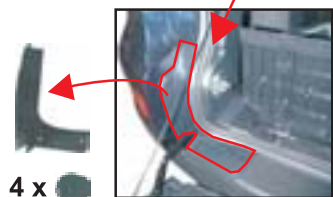

4 x ●



4 x ●

B



1 x ●

1 x ●

2 x ⊕

2 x ⊕

1 x ●

1 x ●

1 x ●

1 x ●

1 x ●

C



9980 A8

D

P3

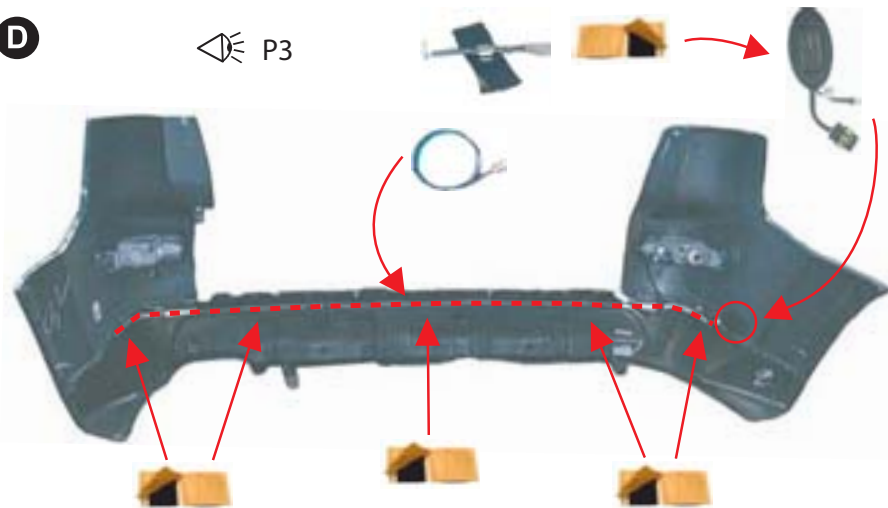

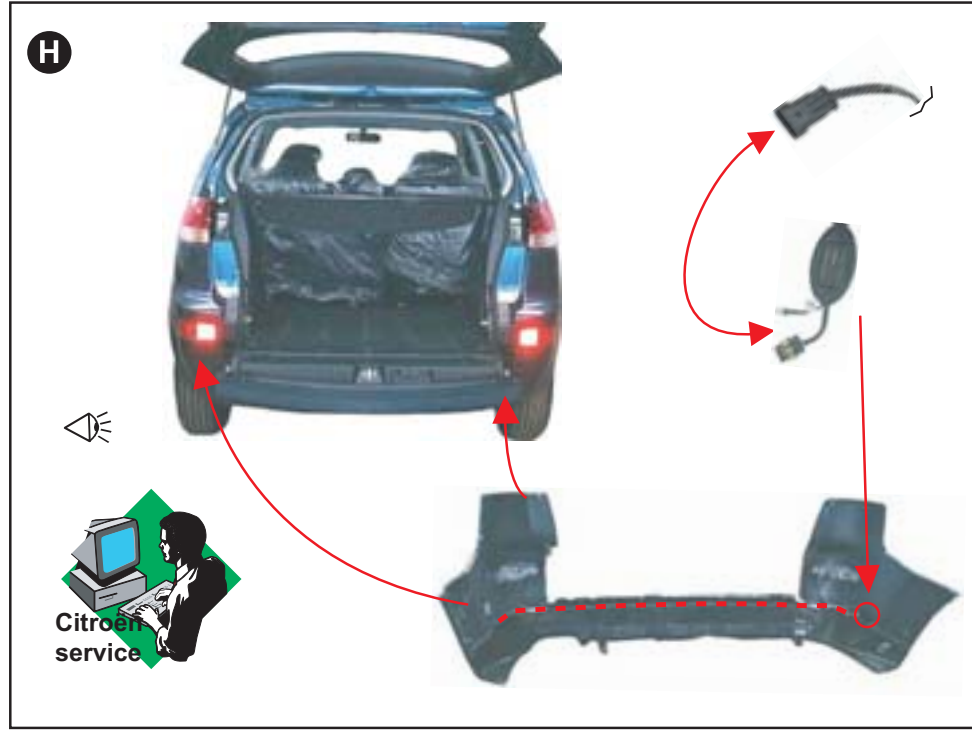
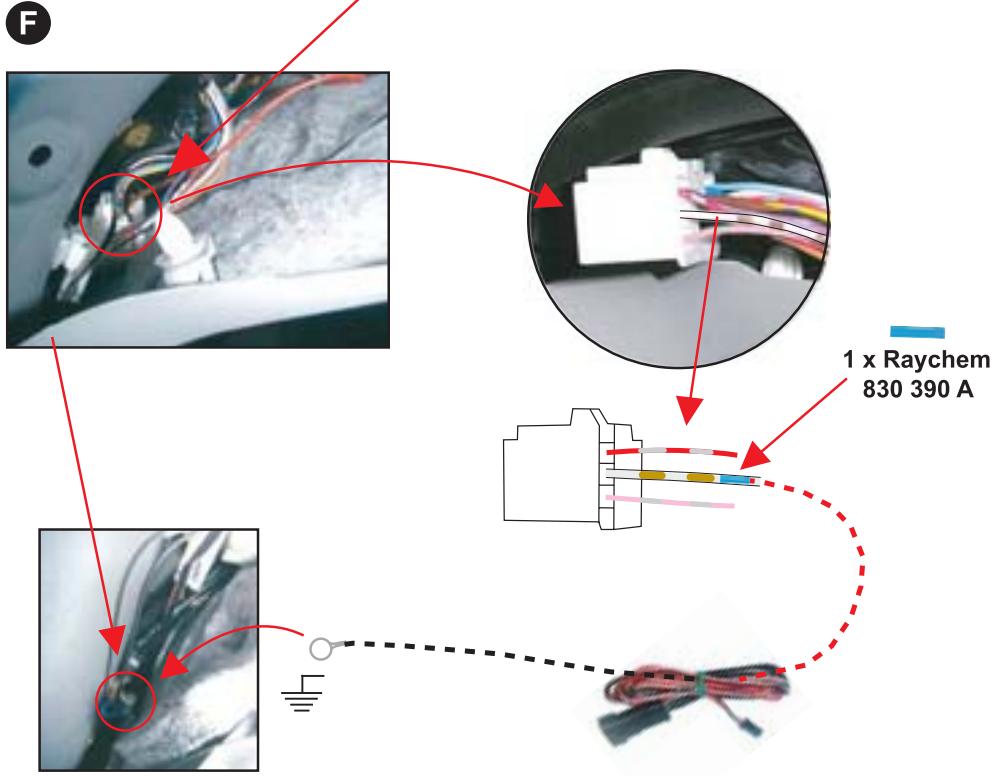
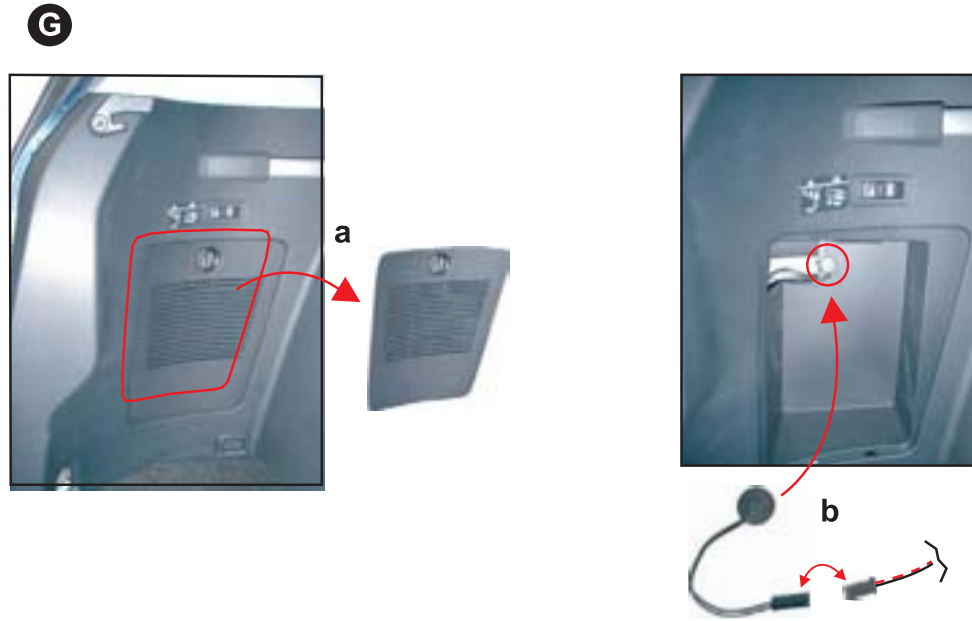
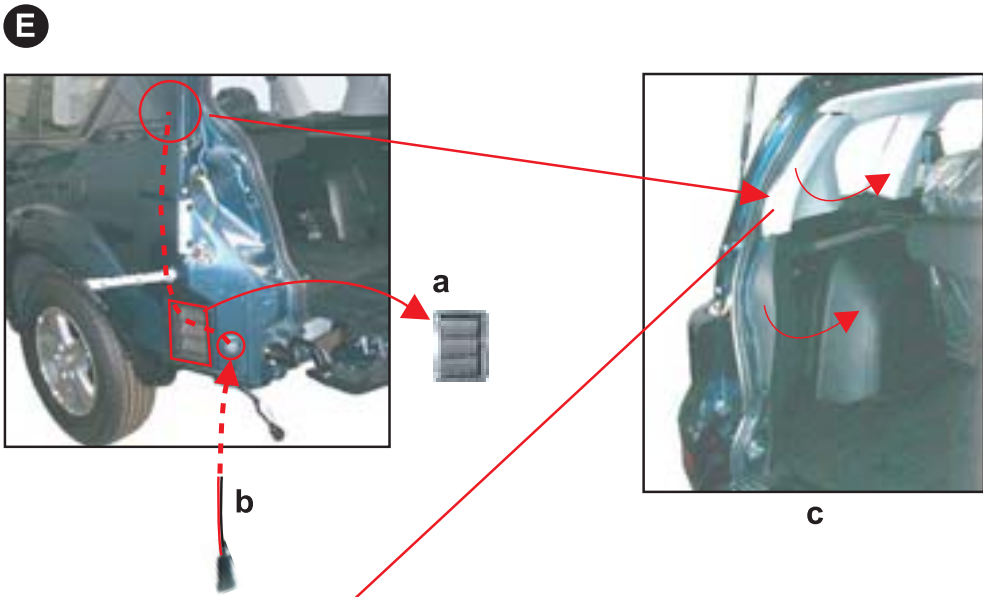

 **Nemo**  Réf: 9452.71



ACT 1440  1.30 H



 T 30  2 x Raychem 830 390 A

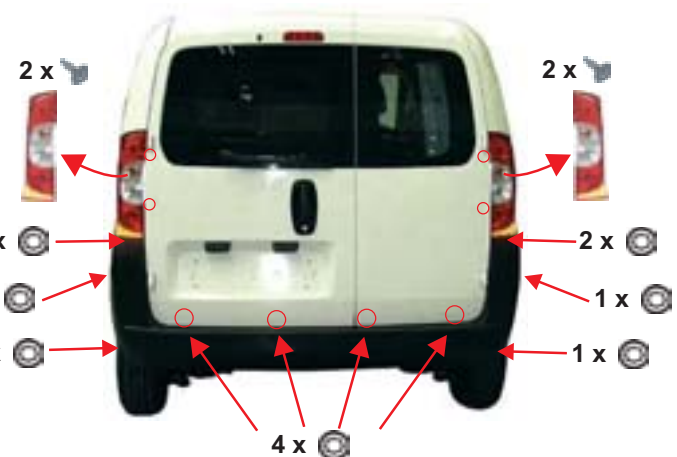

 ①



A  Citroën service







2 x  2 x 

2 x  2 x 



1 x  1 x 

1 x  1 x 

4 x 

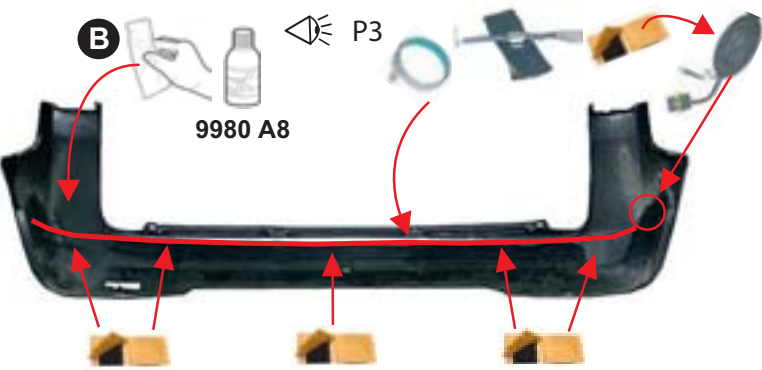
B   9980 A8  P3

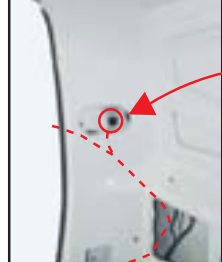
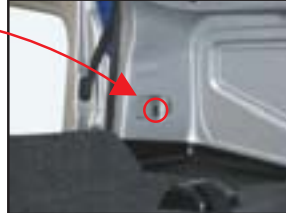

C 

D  **E** 

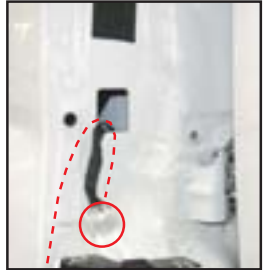
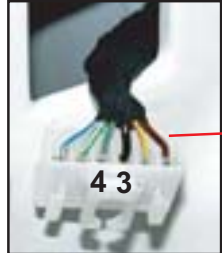
F  

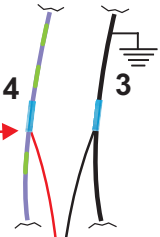
G  

4  3

H   Citroën service 