

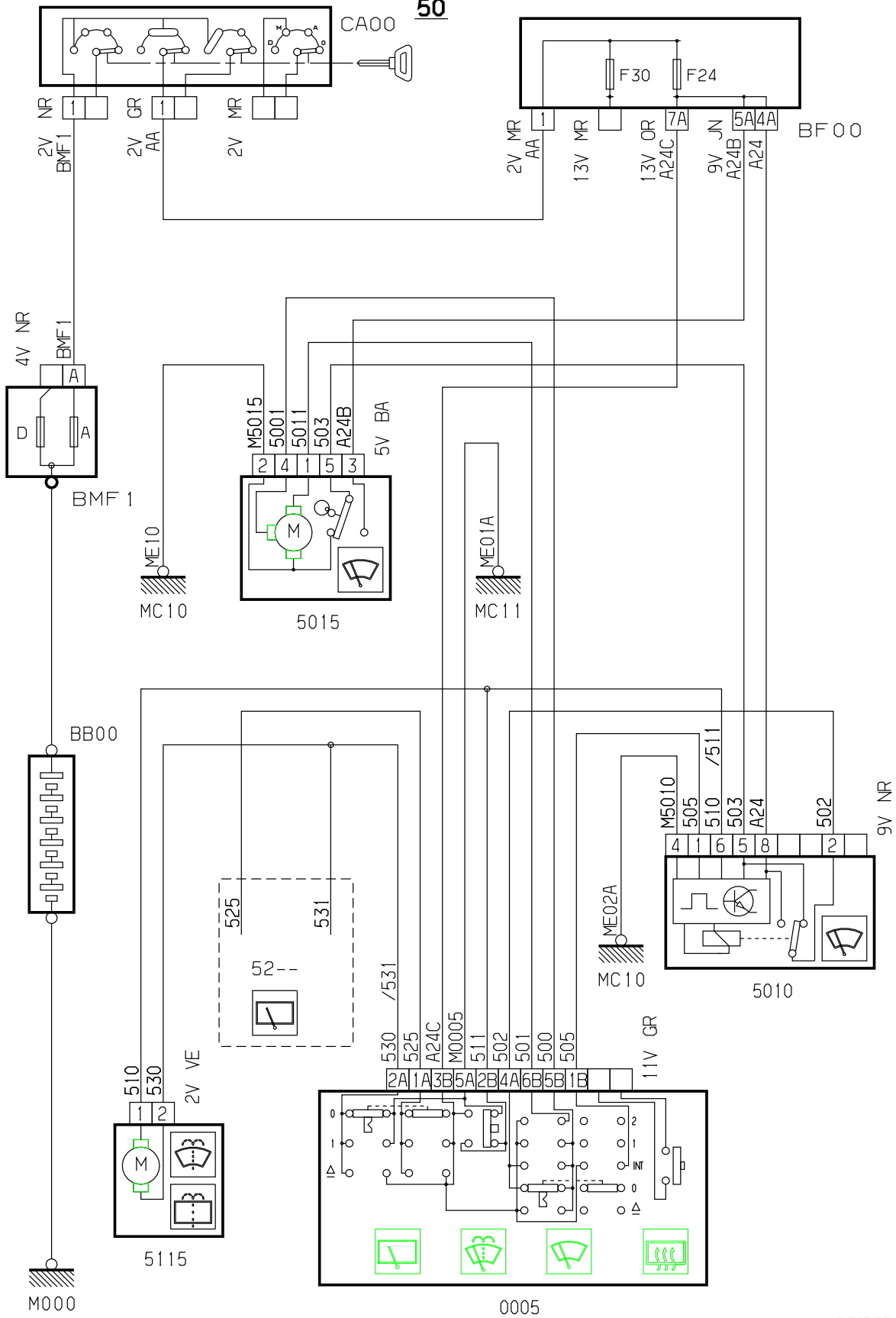



принцип

50



D3AP35YR

прокладка трубопроводов (кабелей, тросов)

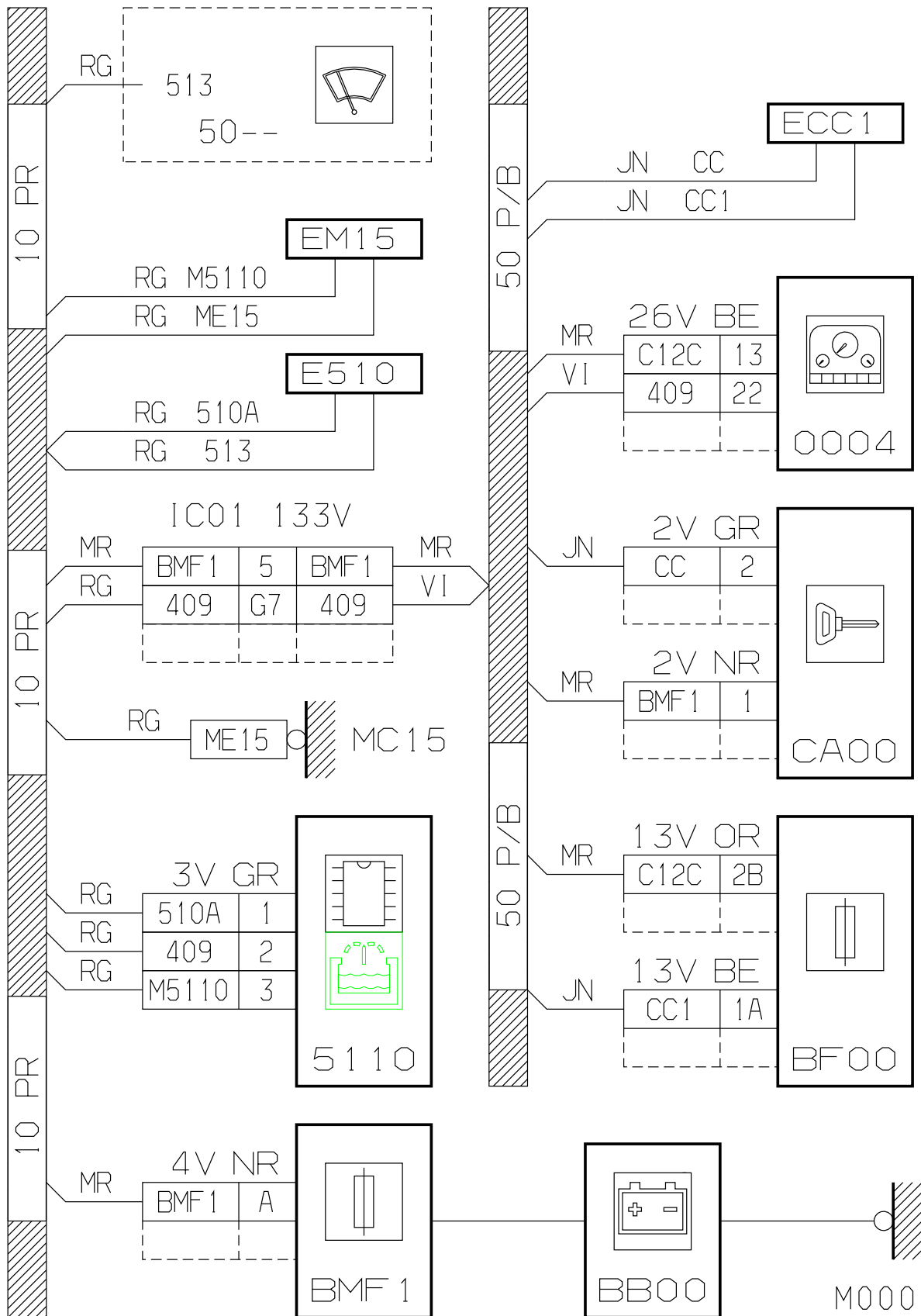

D3AP424G

прокладка трубопроводов (кабелей, тросов)

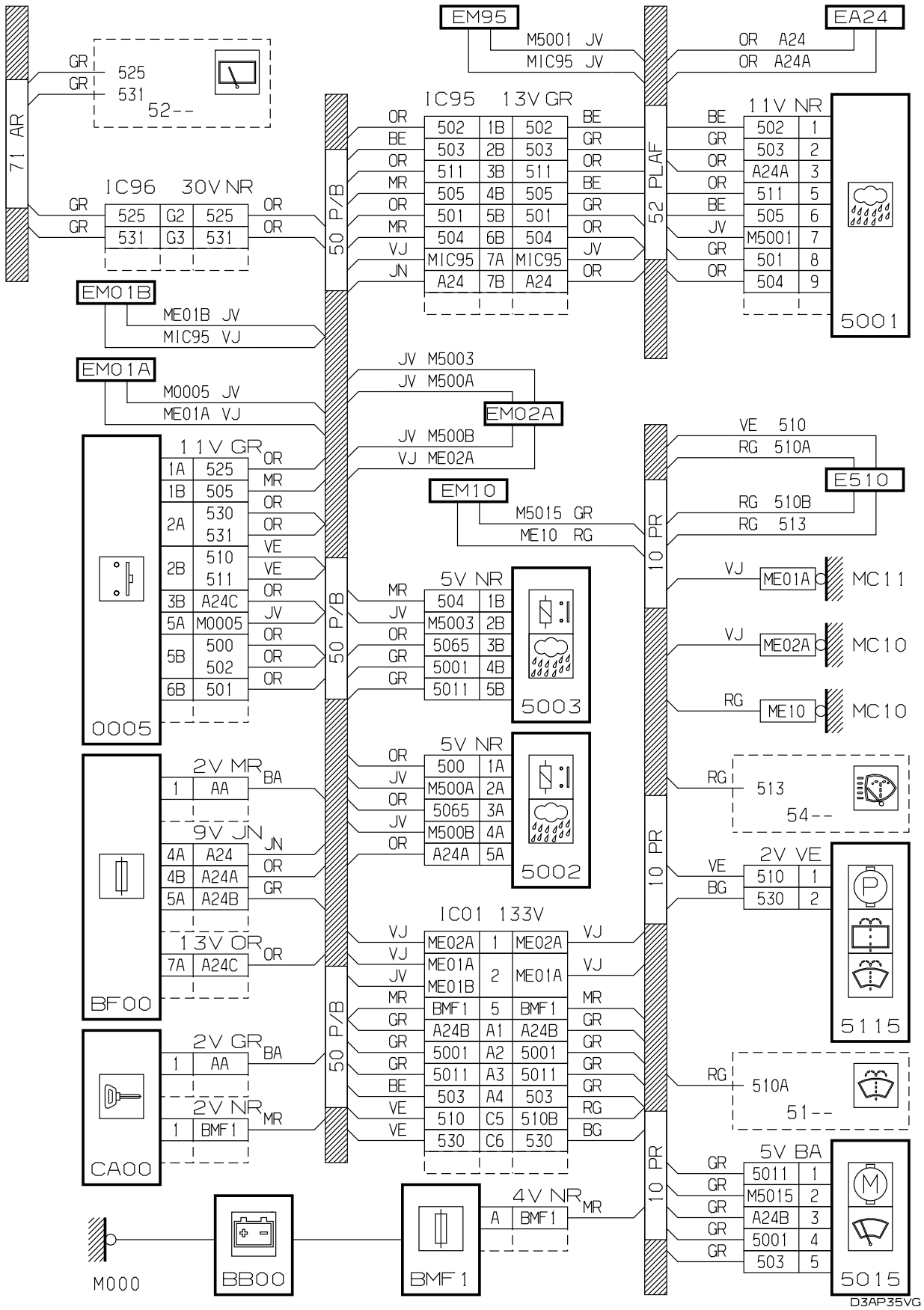

D3AP35VG

прокладка трубопроводов (кабелей, тросов)

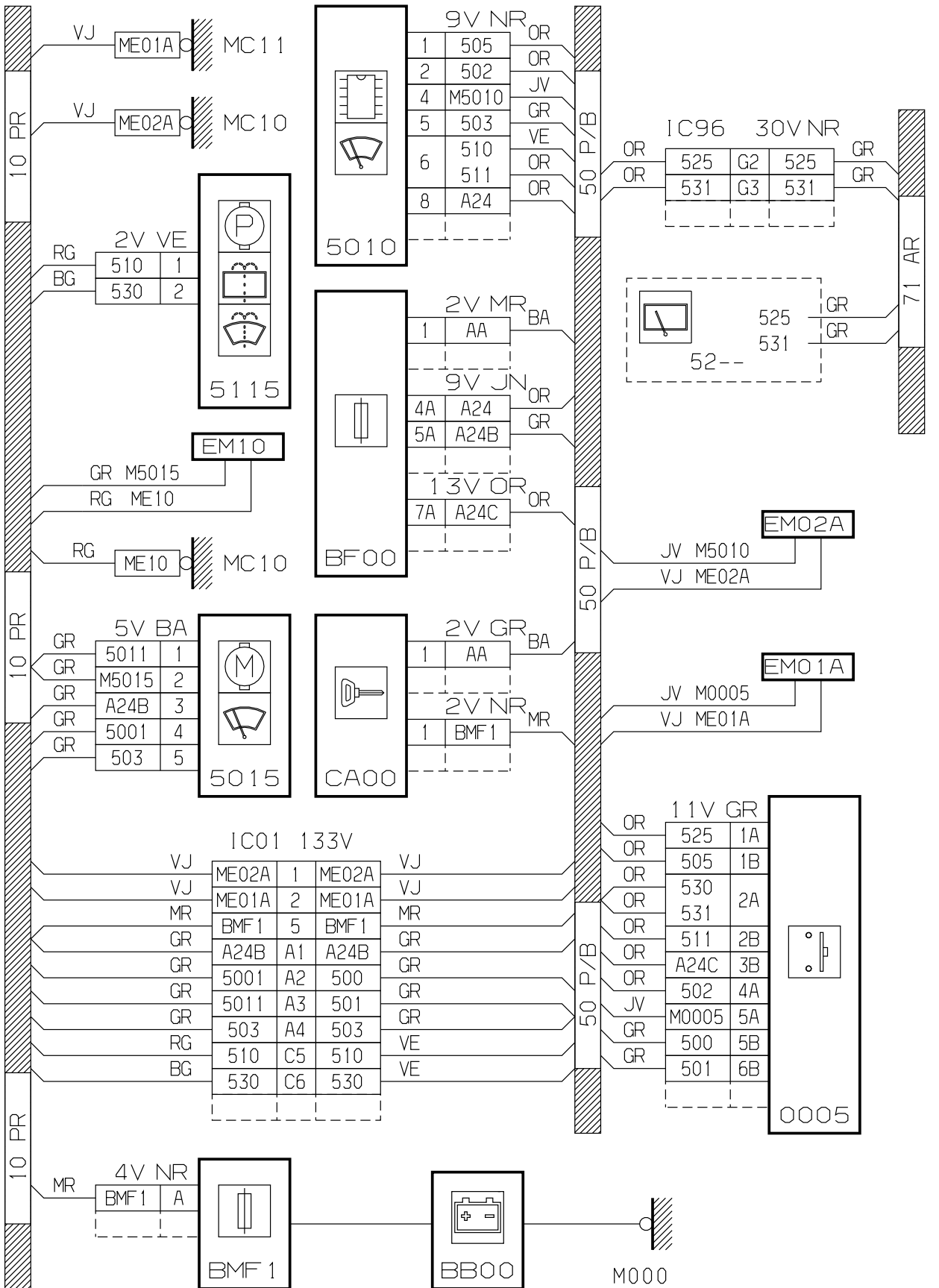

D3AP35YG

null

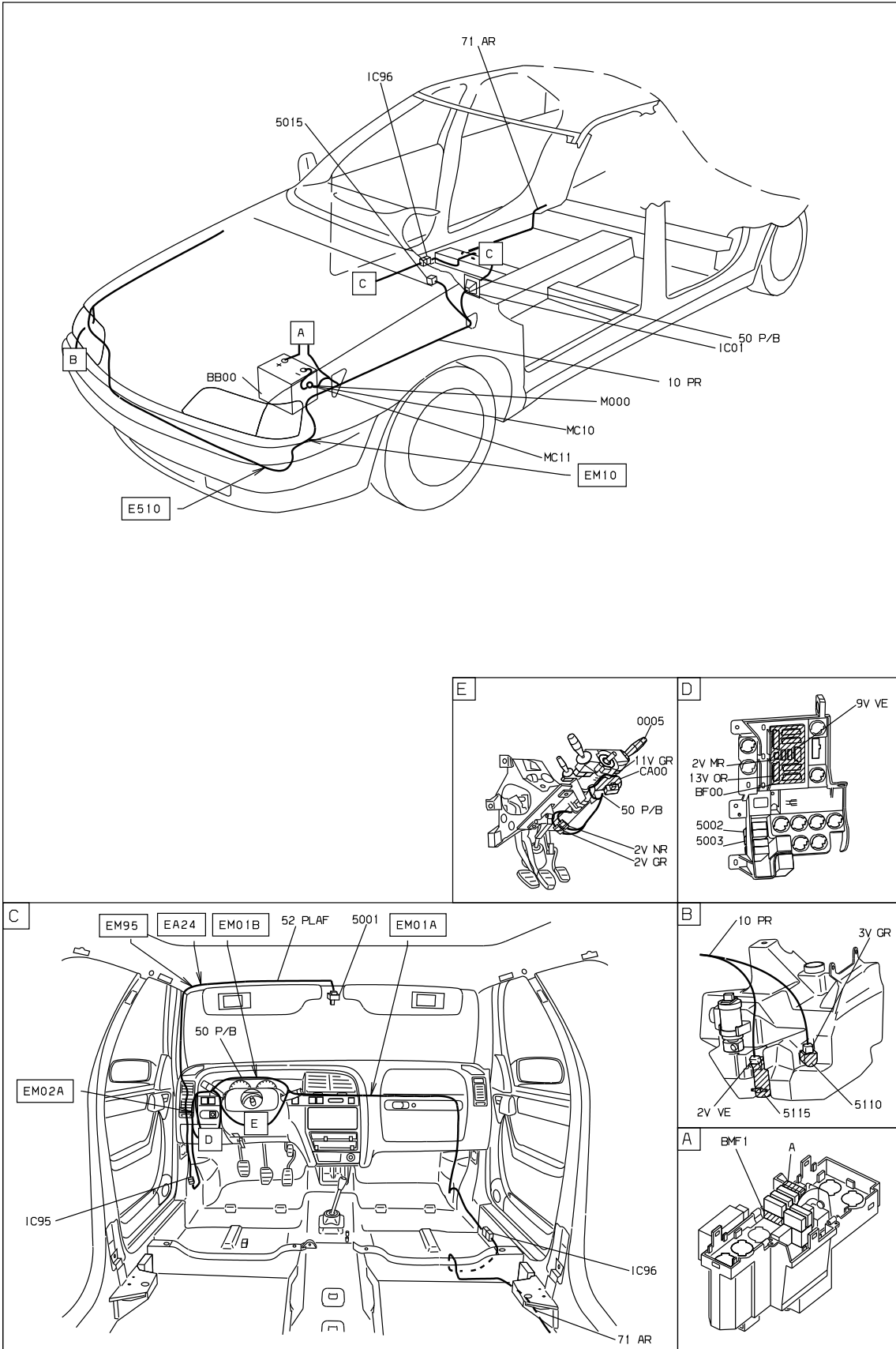

D3AP35V1

null

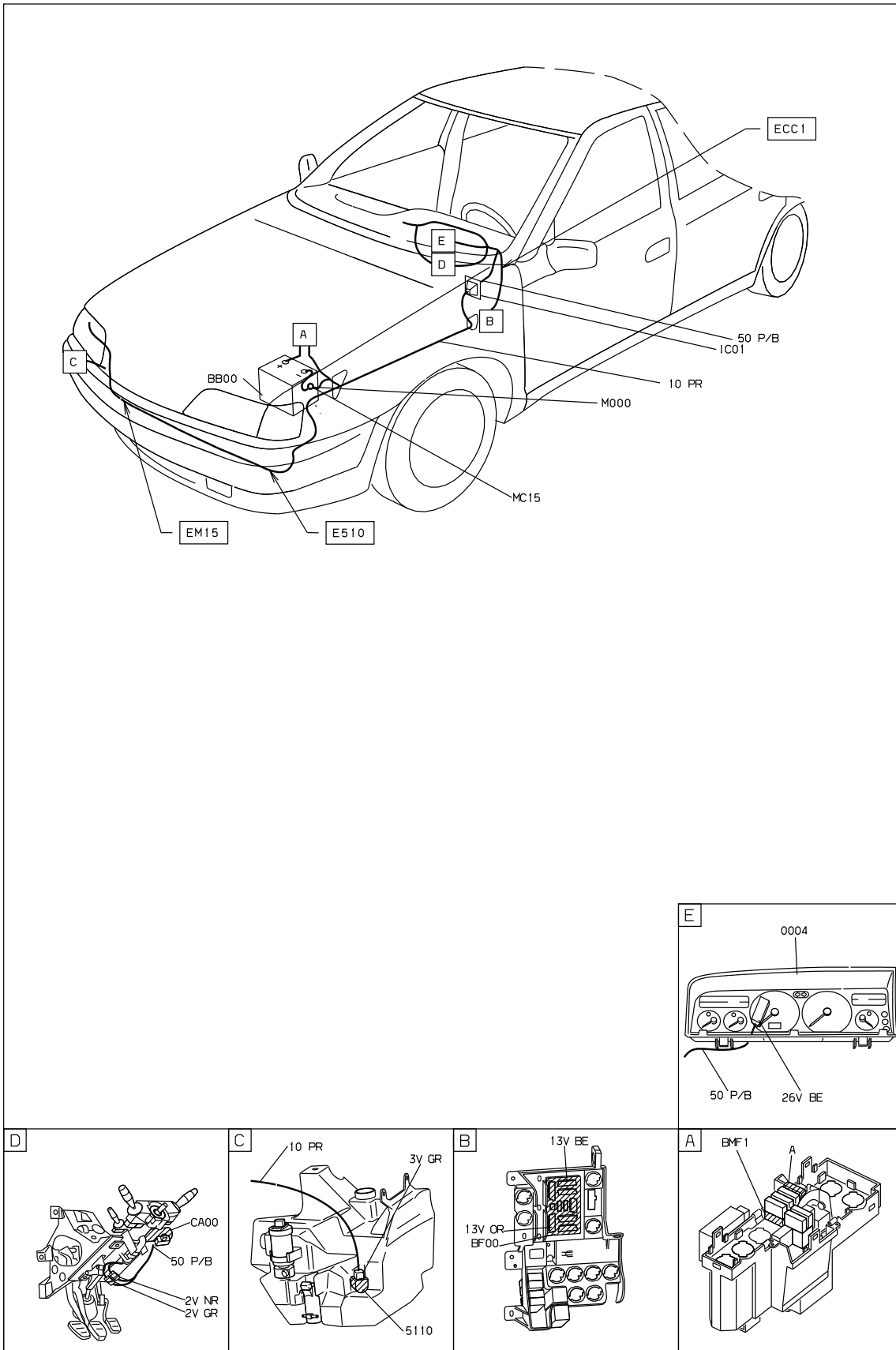

D3AP424 I

null

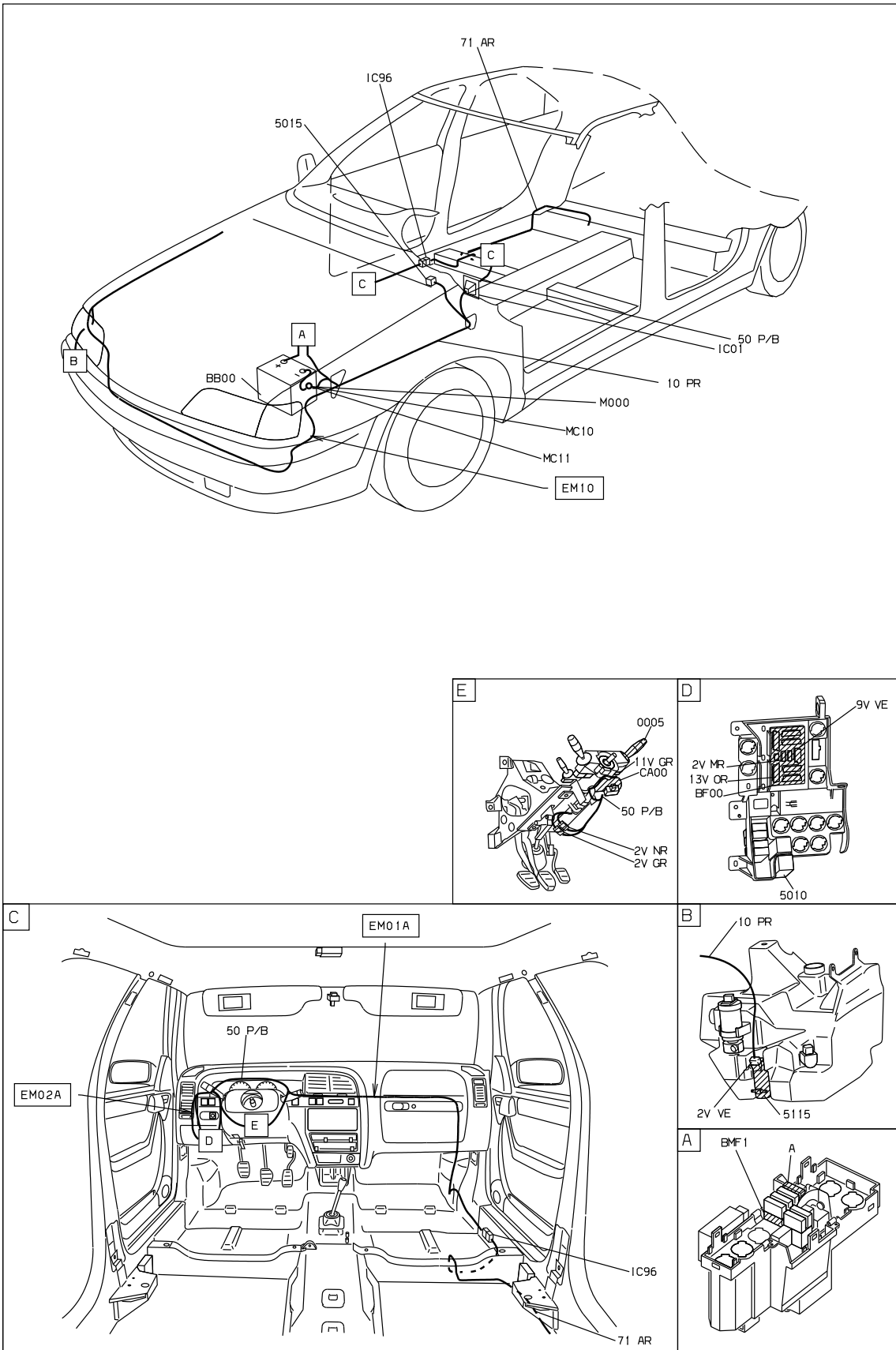

D3AP35Y1

собственность PSA Peugeot Citroen

30/01/2022