

MULTIPLEXED BSI OPERATING PRINCIPLE FOR THE XSARA PICASSO AND XSARA

CITROËN UK LTD
221 BATH ROAD
SLOUGH SL1 4BA

DEALER PERSONNEL
DEVELOPMENT AND
TRAINING

© CITROËN UK LTD. Reproduction whether partial or in full without
written permission from Citroën UK Ltd is forbidden



DOCUMENT SUMMARY

MULTIPLEXED BSI OPERATING PRINCIPLE for the XSARA PICASSO AND XSARA

The aim of this document is to explain certain functions of the BSI (Built-in Systems Interface).

After presenting multiplexing, the following subjects will be dealt with:

Electrical functions of the XSARA and XSARA PICASSO.

- Signalling.
- Interior lighting.
- Driver's information.
- Visibility.
- Locking and unlocking.
- Automatic climate control.
- Immobilisation.
- Radio system.

CONTENTS

PARTS 1 MULTIPLEXING / BSI XSARA AND XSARA PICASSO

CHAPTER 1 : MULTIPLEXING	PAGE 1
I - BRIEF DEFINITION.....	PAGE 1
II - PURPOSE OF MULTIPLEXING	PAGE 1
III - DESIGN OF THE XSARA PICASSO AND XSARA MULTIPLEXED NETWORK.....	PAGE 2
IV - THE VAN PROTOCOL	PAGE 3
V - LOCATION OF MULTIPLEXED ECUS	PAGE 5
CHAPTER 2 : BUILT-IN SYSTEMS INTERFACE	PAGE 7
I - FUNCTIONS CONTROLLED BY THE BSI ON THE XSARA PICASSO AND THE XSARA	PAGE 8
II - BSI LAYOUTS ON THE XSARA PICASSO AND XSARA.....	PAGE 9
III - BSI INPUTS.....	PAGE 11
IV - BSI OUTPUTS	PAGE 13
V - LOCATION AND TYPE OF THE CONNECTORS ON THE BSI	PAGE 16
VI - CHANNEL ALLOCATION ON THE BSI	PAGE 17
VII - OPERATING MODES	PAGE 23
VIII - AFTER-SALES OPERATIONS, ACCESSORIES.....	PAGE 24
CHAPTER 3 : ELECTRICITY	PAGE 29
I - LAYOUT DIAGRAM	PAGE 29
II - PARTS LIST	PAGE 30

MULTIPLEXED BSI - XSARA PICASSO AND XSARA – PART 1

CONTENTS

PART 2 SIGNALLING XSARA AND XSARA PICASSO

CHAPTER 1 : GENERAL	PAGE 33
I - FOREWORD	PAGE 33
II - GENERAL LAYOUT	PAGE 33
CHAPTER 2 : OPERATING PRINCIPLE	PAGE 35
I - INDICATOR FUNCTION.....	PAGE 35
II - HAZARD WARNING LAMPS FUNCTION.....	PAGE 35
III - FAULTY BULB DETECTION FUNCTION	PAGE 36
CHAPTER 3 : ELECTRICITY	PAGE 37
I - LAYOUT DIAGRAM	PAGE 37
II - PARTS LIST	PAGE 38

PART 3 INTERIOR LIGHTING XSARA AND XSARA PICASSO

CHAPTER 1 : GENERAL	PAGE 41
I - FOREWORD	PAGE 41
II - GENERAL LAYOUT	PAGE 43
CHAPTER 2 : OPERATING PRINCIPLE	PAGE 45
CHAPTER 3 : ELECTRICITY	PAGE 47
I - LAYOUT DIAGRAM	PAGE 47
II - PARTS LIST	PAGE 48

CONTENTS

PART 4 DRIVER'S INFORMATION XSARA PICASSO

CHAPTER 1 : GENERAL	PAGE 53
I - FOREWORD	PAGE 53
II - LAYOUT	PAGE 54
III - XSARA PICASSO CONTROL PANEL	PAGE 61
CHAPTER 2 : MESSAGES AND WARNINGS FUNCTION	PAGE 65
I - DISPLAY	PAGE 65
II - PRIORITY LEVELS	PAGE 65
III - WARNINGS FROM WIRE INFORMATION	PAGE 66
IV - WARNINGS FROM THE VAN FRAMES	PAGE 67
CHAPTER 3 : INSTRUMENTATION FUNCTION	PAGE 69
I - COOLANT TEMPERATURE GAUGE AND WARNING FUNCTION..	PAGE 69
II - FUEL LEVEL GAUGE FUNCTION	PAGE 74
III - SPEEDOMETER FUNCTION.....	PAGE 77
IV - MILEOMETER FUNCTION	PAGE 79
V - MAINTENANCE INDICATOR FUNCTION.....	PAGE 80
VI - CLOCK / DATE / TEMPERATURE FUNCTION.....	PAGE 84
CHAPTER 4 : LIGHTING FUNCTION	PAGE 87
I - RHEOSTAT FUNCTION.....	PAGE 87
II - NIGHT DRIVING FUNCTION.....	PAGE 88
CHAPTER 5 : ON-BOARD ECU FUNCTION	PAGE 91
I - GENERAL	PAGE 91
II - LAYOUT	PAGE 92
III - OPERATING MODES	PAGE 93
CHAPTER 6 : ELECTRICITY	PAGE 95
I - LAYOUT DIAGRAM	PAGE 95
II - PARTS LIST	PAGE 98

MULTIPLEXED BSI - XSARA PICASSO AND XSARA – PART 1

CONTENTS

PART 5 DRIVER'S INFORMATION XSARA

CHAPTER 1 : GENERAL	PAGE 103
I - FOREWORD	PAGE 103
II - LAYOUT	PAGE 104
CHAPTER 2 : WARNING FUNCTION	PAGE 107
I - LIST OF LEDS	PAGE 107
II - INTEGRATED BUZZER	PAGE 108
III - WARNING APPEARANCE CONDITIONS	PAGE 108
CHAPTER 3 : INSTRUMENTATION FUNCTION.....	PAGE 111
I - MAINTENANCE INDICATOR.....	PAGE 111
II - OIL LEVEL GAUGE	PAGE 113
III - MILEOMETER	PAGE 114
CHAPTER 4 : REPAIRING THE CONTROL PANEL	PAGE 115
I - READING AND ERASING FAULTS	PAGE 115
II - PROGRAMMING THE MAINTENANCE TYPE.....	PAGE 115
III - ACTUATOR TEST	PAGE 115
IV - READING THE FOLLOWING PARAMETERS	PAGE 116

CONTENTS

PART 6 VISIBILITY XSARA AND XSARA PICASSO

CHAPTER 1 : GENERAL	PAGE 119
I - FOREWORD	PAGE 119
II - GENERAL LAYOUT	PAGE 120
CHAPTER 2 : OPERATING PRINCIPLE	PAGE 123
I - WINDSCREEN WIPER FUNCTION	PAGE 123
II - REAR WIPER FUNCTION	PAGE 125
III - MANAGEMENT OF WIPER PARKED POSITIONS	PAGE 126
IV - WIPER PROTECTION	PAGE 126
V - DE-ICING	PAGE 126
VI - HEADLAMP WASHER TIMER	PAGE 127
CHAPTER 3 : ELECTRICITY	PAGE 129
I - LAYOUT DIAGRAM	PAGE 129
II - PARTS LIST	PAGE 130

PART 7 LOCKING / UNLOCKING XSARA AND XSARA PICASSO

CHAPTER 1 : GENERAL	PAGE 135
I - FOREWORD	PAGE 135
II - GENERAL LAYOUT	PAGE 138
CHAPTER 2 : OPERATING PRINCIPLE	PAGE 141
I - LOCKING / UNLOCKING	PAGE 141
II - DEADLOCKING	PAGE 147

MULTIPLEXED BSI - XSARA PICASSO AND XSARA – PART 1

CONTENTS

PART 8 AUTOMATIC CLIMATE CONTROL XSARA PICASSO

CHAPTER 1 : GENERAL	PAGE 151
I - FOREWORD	PAGE 151
II - GENERAL LAYOUT	PAGE 152
III - LAYOUT DIAGRAM	PAGE 155
IV - DESCRIPTION OF THE USER DISPLAY AND CONTROLS.....	PAGE 156
CHAPTER 2 : OPERATING PRINCIPLE	PAGE 159
I - COMPRESSOR MANAGEMENT FUNCTION.....	PAGE 159
II - ADDITIONAL ELECTRIC HEATING FUNCTION.....	PAGE 164
III - DE-ICING FUNCTION.....	PAGE 164
IV - DOWNGRADED MODES	PAGE 165
V - DIAGNOSTICS	PAGE 166
CHAPTER 3 : ELECTRICITY	PAGE 167
I - LAYOUT DIAGRAM - TU5JP	PAGE 167
III - LAYOUT DIAGRAM - EW7	PAGE 168
V - LAYOUT DIAGRAM - DW10	PAGE 169
IV - PARTS LIST	PAGE 170

CONTENTS

PART 9

VEHICLE IMMOBILISATION XSARA AND XSARA PICASSO

CHAPTER 1 :	TRANSPONDER SYSTEM OPERATING PRINCIPLE	PAGE 175
I -	FOREWORD	PAGE 175
II -	GENERAL LAYOUT	PAGE 176
III -	OPERATION.....	PAGE 177
CHAPTER 2 :	OPERATING PRINCIPLE OF THE FACTORY FITTED ANTI-INTRUSION ALARM.....	PAGE 179
I -	FOREWORD	PAGE 179
II -	GENERAL LAYOUT	PAGE 180
III -	OPERATION.....	PAGE 181
CHAPTER 3 :	OPERATING PRINCIPLE OF THE AFTER-SALES FITTED ANTI-INTRUSION ALARM.....	PAGE 185
I -	FOREWORD	PAGE 185
II -	GENERAL LAYOUT	PAGE 186
III -	OPERATION.....	PAGE 187
CHAPTER 4 :	OPERATING PRINCIPLE OF THE SYSTEM STATUS LED.....	PAGE 191
I -	FUNCTION	PAGE 191
II -	FUNCTIONAL DESCRIPTION	PAGE 191
CHAPTER 5 :	ELECTRICITY	PAGE 193
I -	LAYOUT DIAGRAM	PAGE 193
II -	PARTS LIST	PAGE 194

MULTIPLEXED BSI - XSARA PICASSO AND XSARA – PART 1

CONTENTS

PART 10 RADIO AND COMPACT DISC CHANGER XSARA PICASSO

CHAPTER 1 : GENERAL	PAGE 199
I - FOREWORD	PAGE 199
II - GENERAL LAYOUT	PAGE 200
CHAPTER 2 : RADIO OPERATING PRINCIPLE	PAGE 203
I - SWITCHING ON / OFF	PAGE 203
II - RADIO ANTI-THEFT FUNCTION	PAGE 204
III - CONTROLLING THE BRIGHTNESS	PAGE 204
IV - VOLUME AUTOMATICALLY LINKED TO VEHICLE SPEED	PAGE 204
V - THERMAL PROTECTION	PAGE 205
VI - CONFIGURATION	PAGE 205
CHAPTER 3 : ELECTRICITY	PAGE 207
I - LAYOUT DIAGRAM	PAGE 207
II - PARTS LIST	PAGE 208

PART 1

MULTIPLEXING / BSI
XSARA AND XSARA PICASSO

MULTIPLEXED BSI - XSARA PICASSO AND XSARA – PART 1

MULTIPLEXING

I - BRIEF DEFINITION

Multiplexing is different from previous electrical technology in that it involves transmitting several items of digital information between various devices on a single transmission channel, in the form of 2 wires.

II - PURPOSE OF MULTIPLEXING

Multiplexing is used to:

- simplify electrical harnesses,
- increase functions (for the same number of wires).

MULTIPLEXED BSI - XSARA PICASSO AND XSARA – PART 1

III - DESIGN OF THE XSARA PICASSO AND XSARA MULTIPLEXED NETWORK

XSARA PICASSO design

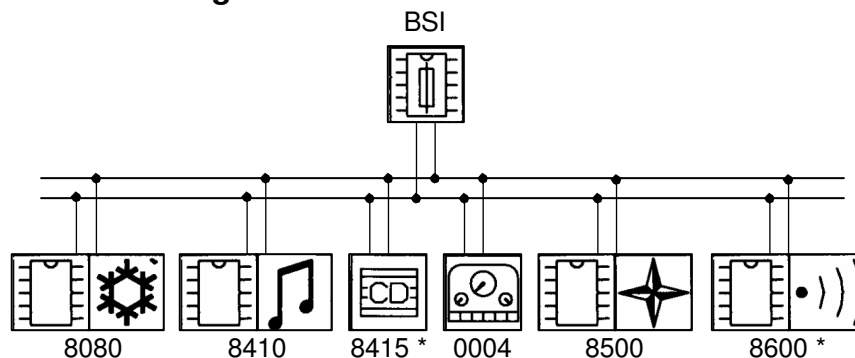

XSARA design

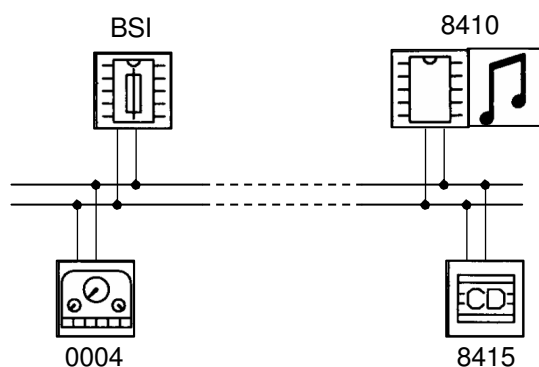

Key: The dotted lines represent a connection used only by the diagnostic function.

*	Available as an accessory	8410	Radio
BSI	Built-in Systems Interface	8415	CD changer
0004	Control panel / Multifunction screen	8500	Navigation
8080	Automatic climate control	8600	Alarm

For the XSARA Picasso, a MultiFunction Screen is incorporated into the control panel:

- MultiFunction Screen type B,
- MultiFunction Screen type C (for navigation option).

There is no MultiFunction Screen on the XSARA.

A communications protocol defines the rules and format of the exchanges between the various ECUs. The communications protocol used on the XSARA and XSARA PICASSO is the VAN.

MULTIPLEXED BSI - XSARA PICASSO AND XSARA – PART 1

IV - THE VAN PROTOCOL

The network consists of 2 wires, called:

- Data,
- Data B (Data bar).

The Data B wire is so called because the voltage at its terminals is always opposite to the voltage on Data.

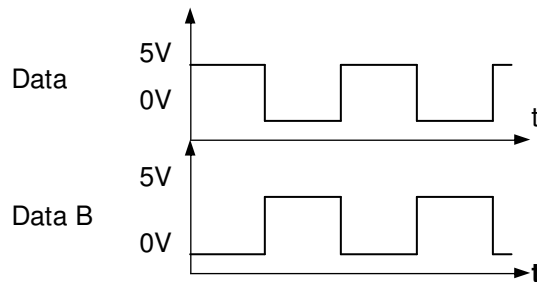

Two current levels are used to encode two distinct logical states.

This process is used to:

- limit the radiation given off,
- provide good resistance to interference.

There is an advantage in using these two wires and electronic circuits for emitting and receiving signals. It allows operation in downgraded mode if one of the wires is broken or short circuited to +12V or to earth.

If a wire breaks, the electronics compares the current level of the signal compared to a reference. The electronics signals the data line faults.

Format of the communications message (frame): Only the rate of the Data line is represented as the Data B line is the opposite.

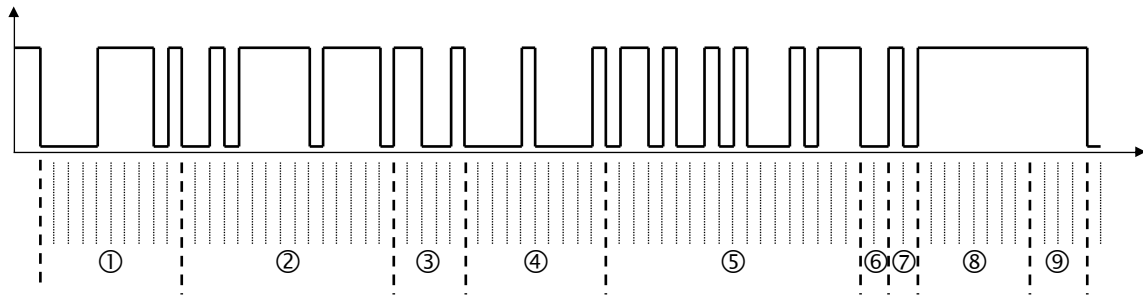

A message in a multiplexed device is unambiguous. It is therefore not possible for an error to occur regarding the recipient nor the nature of the command to be performed.

A frame consists of 9 fields:

- ① a start of message identifier used to locate the start of the message.
- ② an arbitration identification field used to specify the recipient or recipients of the message.
- ③ this field specifies whether an acknowledgement request from the receiver is required, depending on whether it involves a request for or distribution of information.
- ④ a field containing the data of the message.
- ⑤ a validity control field for the message in order to check the integrity of the data upon arrival.
- ⑥ a field marking the end of the actual data to indicate that the message is finished.
- ⑦ an acknowledgement field which allows the receiver to confirm that the message has been correctly received.
- ⑧ an end of frame field.
- ⑨ a frame separator which allows the next frame to use the same sequence of 9 fields.

The electrical signals conveyed by the two wires are square and follow an information encoding sequence. Only the ECUs of the system can interpret them.

IMPORTANT: It is forbidden to connect a measuring device (multimeter, etc) to the VAN network.

Data and Data B wires can be repaired using Raychem connectors.

MULTIPLEXED BSI - XSARA PICASSO AND XSARA – PART 1

V - LOCATION OF MULTIPLEXED ECUS

XSARA PICASSO

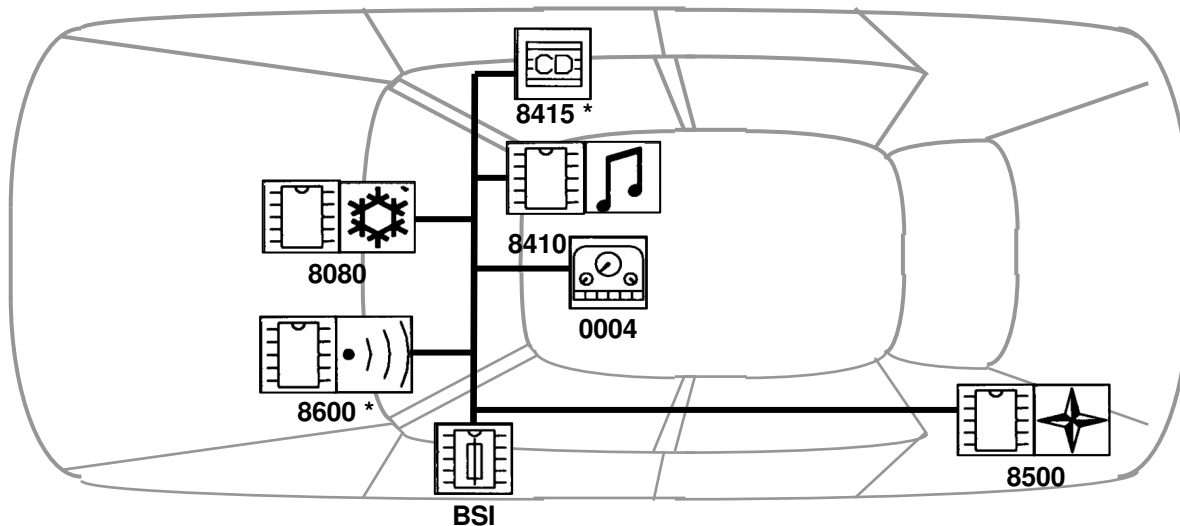

XSARA

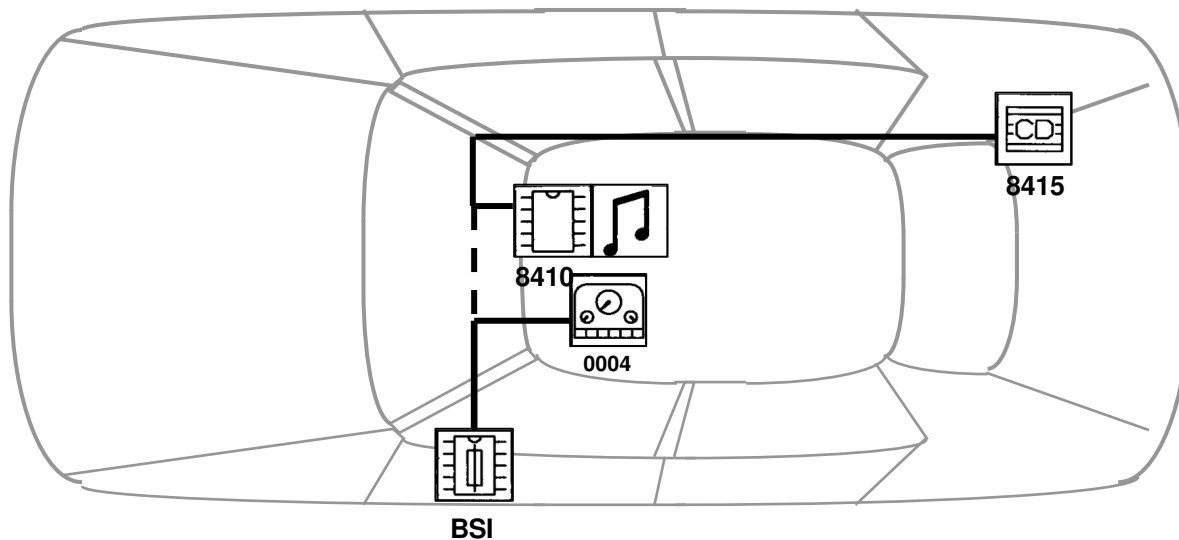

*	Available as an accessory	8410	Radio
BSI	Built-in Systems Interface	8415	CD changer
0004	Control panel / Multifunction screen	8500	Navigation
8080	Automatic climate control	8600	Alarm

MULTIPLEXED BSI - XSARA PICASSO AND XSARA – PART 1

BUILT-IN SYSTEMS INTERFACE

The Built-in Systems Interface (BSI) is an ECU which incorporates:

- **Interface electronics** (relays, fuses, diagnostic socket, HF receiver)
- **Control electronics:** The BSI is one of the masters of the VAN network, on which it controls communications between the ECUs
- **Calculation electronics:** this controls the basic functions in an autonomous manner (locking of the doors, signalling, visibility, interior lighting, engine immobiliser, etc).
- **Information about the vehicle** for the anti-theft protection (vehicle's VIN code, key codes, HF remote control code, radio identification, etc)
- **A program** which is used to control the system and perform diagnostics and configuration procedures.

The BSI acts as a gateway between the VAN network and the diagnostic tool.

In addition, it helps with energy management by controlling reduced consumption modes for itself and the other multiplexed ECUs.

I - FUNCTIONS CONTROLLED BY THE BSI ON THE XSARA PICASSO AND THE XSARA

FUNCTION	DETAILS	XSARA PICASSO	XSARA	
Signalling	Indicator control	X	X	
	Hazard warning lamps button acquisition	X	X	
	Blown bulb detection	X	X	
	Illumination of indicators in the event of an impact	X*		
Locking	Signalling of the locked status of the vehicle	X	X	
	Locking / unlocking using the plip	X	X	
	Locking / unlocking using the interior button	X		
	Unlocking in the event of an impact	X*		
	Rebound function	X	X	
	Boot opening button	X		
	Locking motor protection	X	X	
	Automatic re-locking after 30 seconds of no action	X	X	
	Deadlocking		X	
	Unlocking whilst driving a deadlocked vehicle		X	
	Signalling of the locking status by a system status LED	X		
	Vehicle immobilisation	Encrypted code transponder function	X	X
		BSI - engine management ECU wire connection	X	X
Signalling of engine ECU locked by system status LED		X		
Non multiplexed alarm			X	
Self-powered multiplexed alarm		X	X	
Interior lighting	Timed interior lamps upon opening doors	X	X	
	Progressive extinguishing, progressive illumination	X	X	
	Illumination upon removing the key	X	X	
Windows	Timed supply to electric windows and sunroof	X		
Visibility	Control of normal commands (windscreen washer, etc)	X	X	
	Intermittent wiper function when stationary	X		
	Reduction in wiper speed when stationary	X		
	Rear wiper linked to reverse gear and to windscreen wiper mode	X		
	Automatic windscreen and rear wipers with rain sensor		X	
	Control of wiper parked position	X	X	
	Protection of windscreen and rear wiper motors	X	X	
	Timed de-icing of rear screen and door mirrors	X	X	
	Timed headlamp washers		X	
	Timed extinguishing of headlamps	X		

* Suppressed but may be reinstated

MULTIPLEXED BSI - XSARA PICASSO AND XSARA – PART 1

FUNCTION	DETAILS	XSARA PICASSO	XSARA
Driver's information	Programmable maintenance indicator (through connection on BSI)	X	X
	Acquisition of external temperature	X	
	Time base		X
	Signalling of door status	X	X
	Sidelamps on and key in ignition reminder	X	X
	Automatic gearbox safety warning		X
	Overspeed warning	X	*
	HF remote control battery worn warning	X	X
	Transponder fault warning	X	X
	Driving school pedal set warning		X
	Battery charge, alternator excitation fault warning	X	X
	Acquisition by BSI and transmission of speed information to the control panel	X	X
	Memorising of mileage in the control panel and BSI	X	X
	Memorising of the VIN code and Diagnostic code	X	X
	On-board ECU	X	
Air conditioning	Automatic climate control (RTFA)	X	
	Air conditioning	X	X

RTFA = Refrigeration - Totally Automatic

II - BSI LAYOUTS ON THE XSARA PICASSO AND XSARA

XSARA PICASSO

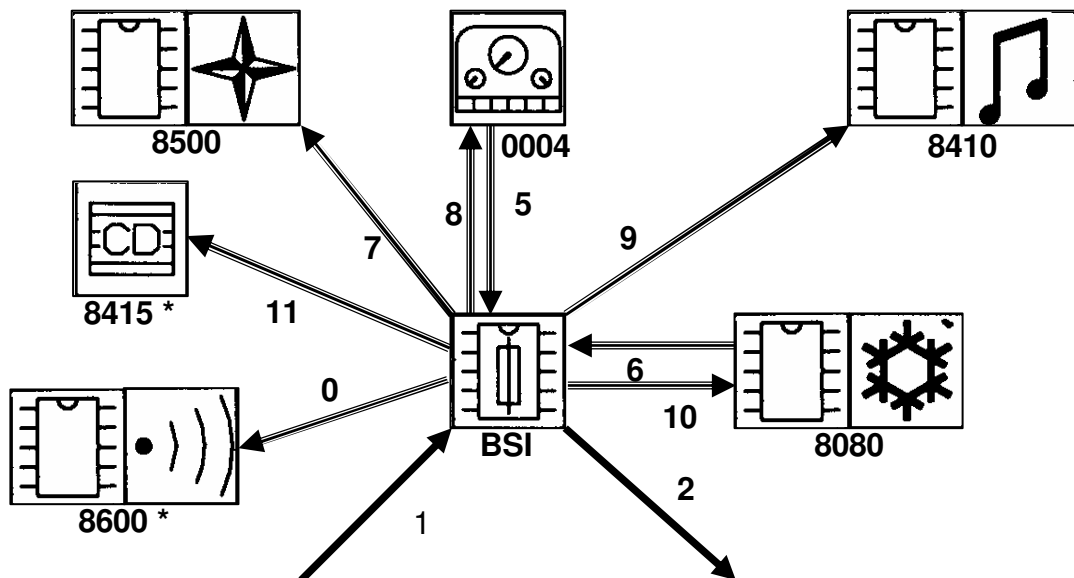

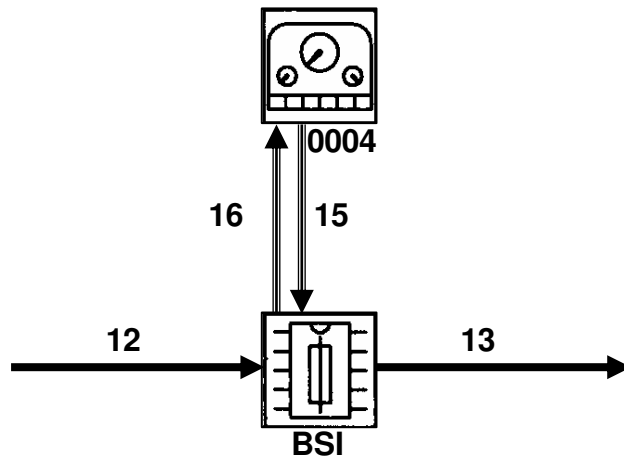

MULTIPLEXED BSI - XSARA PICASSO AND XSARA – PART 1

XSARA



Key:

-  single arrow = wire connection
-  triple arrow = multiplexed connection.

*	Available as an accessory	8410	Radio
BSI	Built-in Systems Interface	8415	CD changer
0004	Control panel / Multifunction screen	8500	Navigation
8080	Automatic climate control	8600	Alarm

Note: The connection numbers are used to associate these diagrams to the input-output tables for the XSARA Picasso (XsP) and the XSARA (Xs).

MULTIPLEXED BSI - XSARA PICASSO AND XSARA – PART 1

III - BSI INPUTS

A - SUPPLIES

DESCRIPTION	EMITTER	TYPE	XSP	XS
+ accessories information Supply to + accessories track for windscreen / rear wash / wipe steering wheel stalk	Ignition switch - accessories - ignition position	All or Nothing Supply	1	12
+ALT permanent power supply	Alternator	Supply	1	12
- +ignition on information - Electronic redundant supply	Ignition switch - ignition - cranking positions	Supply All or Nothing	1	12
+BAT permanent electronic supply, cut off when parked by removing the shunt from the Passenger Compartment Fuse Box	Battery	Supply	1	12
+BAT permanent power supply	Battery	Supply	1	12
+BAT permanent power supply for smartpowers	Battery	Supply	1	12
- Headlamp information - Electrical redundant supply, track for number plate, lighting of buttons	Lighting / headlamp signalling steering wheel stalk	Supply All or Nothing	1	12
Analogue earth for sensors on passenger compartment harness		Earth	1	12
Analogue earth for sensors on main harness		Earth	1	12
ECU earth		Earth	1	12
Power earth		Earth	1	12

B - WIRE INPUTS

DESCRIPTION	ORIGIN	TYPE	XSP	XS
Battery charge / alternator excitation (Input-Output)	Alternator	Analogue	1	12
Air conditioning compressor engaging authorisation	Engine management ECU	All or Nothing	1	12
Rear wiper motor parked position information	Rear wiper motor	All or Nothing	1	12
Windscreen wiper motor parked position information	Windscreen wiper motor	All or Nothing	1	12
Engine coolant temperature warning information	Coolant Temperature Management Unit FRIC Engine management ECU Thermoswitch	All or Nothing	1	12
Impact detection information	Inertia switch	All or Nothing	1	12
Right hand indicators request	Lighting / signalling steering wheel stalk	All or Nothing	1	no
Left hand indicators request	Steering wheel stalk	All or Nothing	1	12
Boot or tailgate not closed switch	Boot switch	All or Nothing	1	no
Central locking request button	Locking information (on dashboard)	All or Nothing	1	12
Driver's door internal opening contact	Driver's door lock	All or Nothing	1	12
Front passenger's door internal opening contact	Passenger's door lock	All or Nothing	1	12
Rear right hand passenger's door open switch	Rear right hand door open switch	All or Nothing	1	12
Rear left hand passenger's door open switch	Rear left hand door open switch	All or Nothing	1	12
Driver's door open switch	Front left hand door open switch	All or Nothing	1	12
Front passenger's door open switch	Front right hand door open switch	All or Nothing	1	12
Bonnet not closed switch	Bonnet switch	All or Nothing	no	12
Fuel flow information	Engine ECU	Frequency	1	12
Engine ECU fault information	Engine ECU	All or Nothing	1	12
On-board ECU scroll request	Steering wheel stalk		1	12
Heated rear screen and door mirrors de-icing request (except RFTA climate control)	De-icing button	All or Nothing	1	12

MULTIPLEXED BSI - XSARA PICASSO AND XSARA – PART 1

DESCRIPTION	ORIGIN	TYPE	XSP	XS
Hazard warning lamps request	Hazard warning lamps button	All or Nothing	1	12
Rear wiper request	Wipers steering wheel stalk	All or Nothing	1	12
Windscreen wipers high speed request	Wipers steering wheel stalk	All or Nothing	1	12
Windscreen wipers intermittent request	Wipers steering wheel stalk	All or Nothing	1	12
Rear screen wash request	Wipers steering wheel stalk	All or Nothing	1	12
Windscreen wash request	Wipers steering wheel stalk	All or Nothing	1	12
Boot open request	Boot opening button	All or Nothing	1	12
Diesel pre-heating information	Engine ECU	All or Nothing	1	12
Air con refrigerant safety information	Pressure switch	All or Nothing	1	12
Windscreen wipers slow speed request	Wipers steering wheel stalk	All or Nothing	1	12
- Reverse gear information - Supply to REVERSE track for reversing lamps	Reverse gear contact	All or Nothing	1	12
Engine speed information	Engine ECU	Frequency	1	12
Air conditioning request (for air con)	Air conditioning panel	All or Nothing	1	12
Locking/unlocking request through lock	Front lock contacts	All or Nothing	1	12
External air temperature information	External air temperature sensor	Analogue	1	12
Engine coolant temperature information (not PSA2000 engine ECU and without FRIC)	Engine coolant temperature sensor	Analogue	1	12
Engine coolant temperature information (PSA2000 engine ECU and with FRIC)	Engine ECU	Frequency	1	12
Air conditioning evaporator temperature information	Evaporator temperature sensor	Analogue	1	12
Vehicle speed information	Speed sensor	Frequency	1	12
Diagnostic serial connector (Input/Output)	Diagnostic tool		1	12

C - MULTIPLEXED INPUTS

DESCRIPTION	ORIGIN	XSARA PIC.	XSARA
Multifunction Screen requests			
Request to reset journey counters	Multifunction screen	5	no
Request to reset tripometers	Multifunction screen C	5	no
Request to maintain +VAN comfort	Multifunction screen	5	no
Control panel status			
Oil pressure warning	Control panel	5	15
Night driving mode	Control panel	5	no
Parking brake	Control panel	5	15
Control panel brightness level	Control panel	5	15
Low fuel information	Control panel	5	15
ABS fault	Control panel	5	15
Electronic brakeforce distribution fault	Control panel	5	15
Brake fluid fault	Control panel	5	15
Automatic gearbox fault	Control panel	no	15
Gross fuel level	Control panel	5	15
Dipped beam	Control panel	5	15
Control panel reading			
Stored mileage	Control panel	5	15
Air conditioning requests			
Air conditioning request	Automatic climate control	6	no
Heated rear screen and door mirrors de-icing request	Automatic climate control	6	no

MULTIPLEXED BSI - XSARA PICASSO AND XSARA – PART 1

IV - BSI OUTPUTS

A - WIRE OUTPUTS

DESCRIPTION	RECEIVER	TYPE	XSP	XS
+ accessories supply for windscreen/rear wash/wipe steering wheel stalk	Steering wheel stalk	All or Nothing	2	13
Air conditioning compressor authorisation	Engine ECU	All or Nothing	2	13
Rear right hand indicator control	Rear right hand indicator	All or Nothing	2	13
Rear left hand indicator control	Rear left hand indicator	All or Nothing	2	13
Front right hand indicator control	Front right hand indicator	All or Nothing	2	13
Front left hand indicator control	Front left hand indicator	All or Nothing	2	13
Right hand repeater indicator control	Right hand repeater indicator	All or Nothing	2	13
Left hand repeater indicator control	Left hand repeater indicator	All or Nothing	2	13
Transponder clock signal	Transponder	Frequency	2	13
Air conditioning compressor clutch control	Air conditioning compressor clutch relay	All or Nothing	2	13
Locking actuator control	Door locks	All or Nothing	2	13
Unlocking actuator control	Door locks	All or Nothing	2	13
Rear wiper motor control	Rear wiper motor	All or Nothing	2	13
Windscreen wiper motor high speed control	Windscreen wiper motor	All or Nothing	2	13
Supply: number plate, button lighting, etc	Items illuminated at night	All or Nothing	2	13
Heated rear screen control	Heated rear screen	All or Nothing	2	13
Supply: front electric window motors, sunroof, rear electric window relay control	Electric window motors, rear electric window relays	All or Nothing	2	13
Low fuel information	Engine ECU	All or Nothing	2	13
Engine running information	Engine running relay	All or Nothing	2	13
Boot opening actuator control	Boot opening lock	All or Nothing	2	13
Rear interior lamp control	Rear interior lamp switch	All or Nothing	2	13
Front interior lamp control	Front interior lamp switch	All or Nothing	2	13
Windscreen wiper motor slow speed control	Windscreen wiper motor	All or Nothing	2	13
Reversing lamps supply	Reversing lamps	All or Nothing	2	13
Sidelamps relay control	Sidelamps relay	All or Nothing	2	no
Heated door mirrors control	Door mirrors relay	All or Nothing	2	13
Engine ECU resupply command for engine immobiliser	Engine ECU double relay	All or Nothing	2	13
Heated rear screen and door mirror lamp control (except RFTA climate control)	De-icing switch	All or Nothing	10	no
Hazard warning lamps button lamp control	Hazard warning lamps button lamp	All or Nothing	2	13
System status LED control	System status LED	All or Nothing	2	no
Supply: VAN bus power on passenger compartment harness	VAN network	All or Nothing	2	13
Supply: VAN bus power on main harness	VAN network	All or Nothing	2	13

MULTIPLEXED BSI - XSARA PICASSO AND XSARA – PART 1

B - MULTIPLEXED OUTPUTS

DESCRIPTION	RECEIVER	XSARA PIC.	XSARA
Fast BSI data			
Engine speed	Control panel/MFS	8	16
Instantaneous vehicle speed	Control panel/MFS, Air conditioning, Radio CD	8, 9, 10	16
Mileage	Control panel/MFS	8	16
Fuel consumption	Control panel/MFS	8	16
Slow BSI data			
Day / Night status	Control panel/MFS, Air conditioning, Radio	8, 9, 10, 11	no
Night driving mode	Control panel/MFS, Air conditioning	8, 10	no
Control panel brightness level (Alarm on stand-by)	Control panel/MFS, Air conditioning Alarm (accessory)	8, 10 0	no no
Factory / Customer mode	MFS, Radio, CD changer	8, 9, 11	16
Reverse gear	Navigation	7	no
Economy mode	Control panel/MFS, Air conditioning, Radio CD	8, 9, 10	16
Set to stand-by in 5 seconds	Control panel/MFS, Air conditioning, Radio, CD changer	8, 9, 10, 11	16
Engine running	Control panel/MFS, Air conditioning	8, 10	16
Position of ignition key	Control panel/MFS, Air conditioning	8, 10	16
Coolant temperature	Control panel/MFS	8	16
Vehicle mileometer	Control panel/MFS	8	16
External temperature	Control panel/MFS, Air conditioning	8, 10	no
BSI configuration			
VIN	Radio	9	no
BSI display			
Coolant temperature warning	Control panel/MFS	8	16
Brake fluid / hydraulic level warning	Control panel/MFS	8	16
Door(s) open, engine running warning	Control panel/MFS	8	16
Oil pressure warning	Control panel/MFS	8	no
Electronic brakeforce distribution fault	Control panel/MFS	8	no
ABS fault	Control panel/MFS	8	16
EOBD fault	Control panel/MFS	8	16
Battery charging fault	Control panel/MFS	8	16
Headlamps left on reminder signal	Control panel/MFS	8	16
Key in ignition reminder signal	Control panel/MFS	8	16
Overspeed signal	Control panel/MFS	8	16
Parking brake	Control panel	8	16
HF plip battery worn	MFS	8	no
Impact sensor signal	MFS	8	no
Electric engine immobiliser system fault	Control panel/MFS	8	16
Vehicle locking status	Control panel/MFS	8	no

MULTIPLEXED BSI - XSARA PICASSO AND XSARA – PART 1

DESCRIPTION	RECEIVER	XSARA PIC.	XSARA
BSI CPL displays			
Front right hand door open	MFS	8	no
Front left hand door open	MFS	8	no
Rear right hand door open	MFS	8	no
Rear left hand door open	MFS	8	no
Boot open	MFS	8	no
Consumption invalid (flowmeter fault)	MFS	8	no
Range invalid (sender fault)	MFS	8	no
Range calculation impossible (fuel level too low)	MFS	8	no
Distance travelled insufficient (less than 400 m since resetting)	MFS	8	no
Journey distance insufficient (less than 400 m since resetting)	MFS C	8	no
Status of on board ECU scroll button	MFS	8	no
Average speed travelled	MFS	8	no
Average journey speed	MFS	8	no
Filtered speed	MFS	8	no
Cumulative distance travelled	MFS	8	no
Average consumption	MFS	8	no
Cumulative journey distance	MFS C	8	no
Average journey consumption	MFS C	8	no
Instant consumption	MFS	8	no
Remaining range	MFS	8	no
BSI event			
Main event present	MFS	8	no
Secondary event present	MFS	8	no
Source of the event	MFS	8	no
Change of signals and modes	MFS	8	no
Change of door status	MFS	8	no
Change of on board ECU data	MFS	8	no
Control panel functions			
Activation of control panel	Control panel	8	16
Pre-heating	Control panel	8	16
Hazard warning lamps	Control panel	8	16
Right hand indicator	Control panel	8	16
Left hand indicator	Control panel	8	16
Air conditioning information			
Air conditioning activation	Automatic climate control	10	no
Compressor authorisation	Automatic climate control	10	no
Heated rear screen operating status	Automatic climate control	10	no
Compressor status	Automatic climate control	10	no
Coolant pressure/temperature, evaporator safety	Automatic climate control	10	no
Evaporator temperature	Automatic climate control	10	no

MULTIPLEXED BSI - XSARA PICASSO AND XSARA – PART 1

V - LOCATION AND TYPE OF THE CONNECTORS ON THE BSI

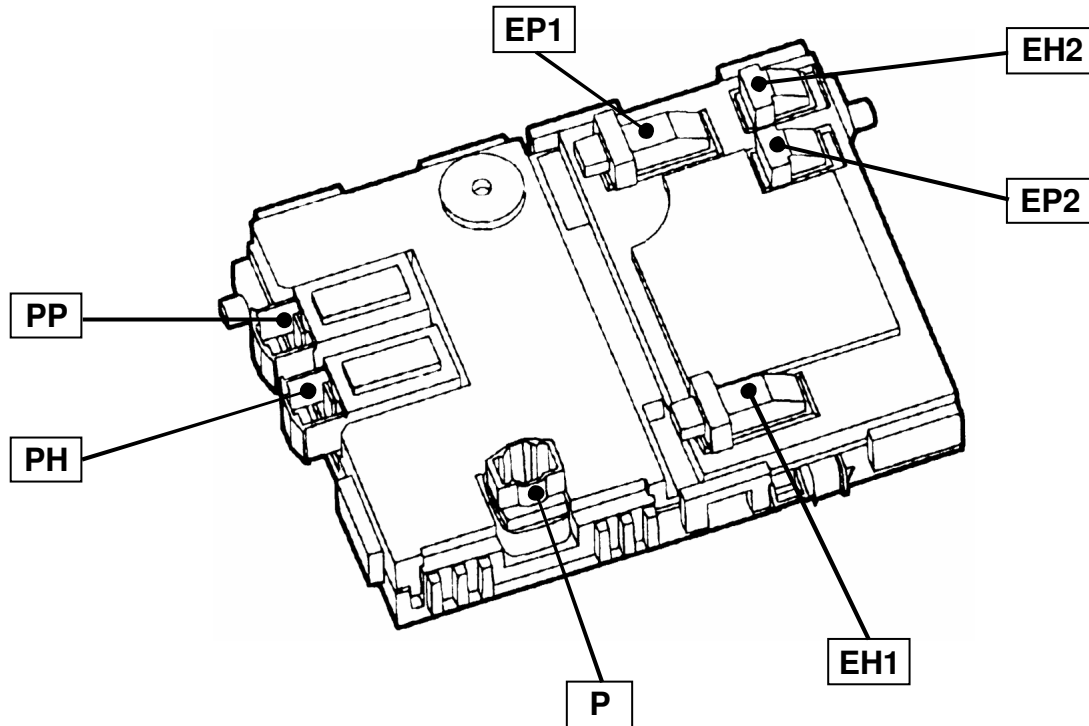

CONNECTOR	DESCRIPTION	CHANNELS	COLOUR
P	Power Supply Connector to main harness	2	GREY
PP	Power Connector to main harness	16	GREEN
PH	Power Connector to passenger compartment harness	16	BLACK
EP1	Electronic Connector to main harness	26	YELLOW
EP2	Electronic Connector to main harness	12	BROWN
EH1	Electronic Connector to passenger compartment harness	26	BLUE
EH2	Electronic Connector to passenger compartment harness	12	BLUE

MULTIPLEXED BSI - XSARA PICASSO AND XSARA – PART 1

VI - CHANNEL ALLOCATION ON THE BSI

BSI inputs/outputs

Power part.

- Allocation of pins of the Grey 2-way NG1 connector of the main harness.

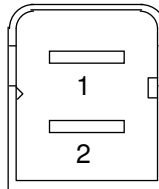

1 - + permanent **+ ПОСТОЯННЫЙ**

2 - + alternator

MULTIPLEXED BSI - XSARA PICASSO AND XSARA – PART 1

- Allocation of pins of the Green 16-way SIGMA connector of the main harness.

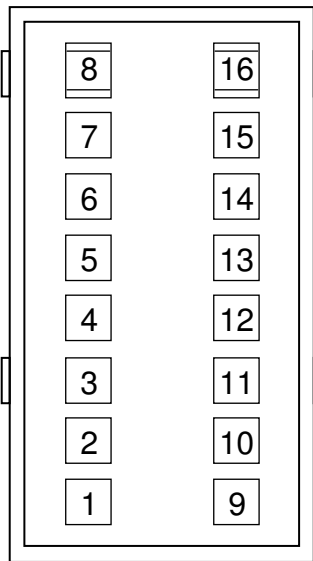

- 8 - Output: Power supply of the VAN bus on main harness
- 7 - Output: Front left hand indicator control
- 6 - Output: Front right hand indicator control
- 5 - Output: + accessories for wash/wipe stalk
- 4 - Input: Lamps
- 3 - Input: Reverse gear switch
- 2 - Power earth **масса**
- 1 - Output: Windscreen wiper slow speed motor control

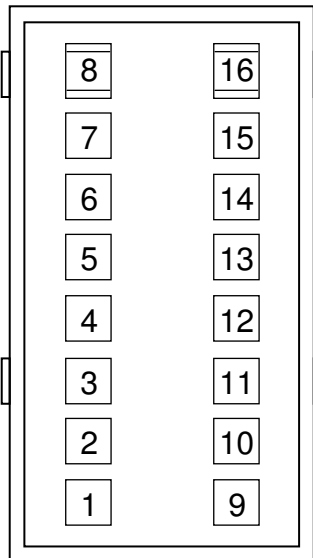

- 16 - + permanent **+ ПОСТОЯННЫЙ**
- 15 - Output: Right hand repeater indicator control
- 14 - Output: Left hand repeater indicator control
- 13 - Output: Air conditioning compressor control
- 12 - Power earth **масса**
- 11 - Spare
- 10 - Spare
- 9 - Output: Windscreen wiper high speed motor control

MULTIPLEXED BSI - XSARA PICASSO AND XSARA – PART 1

- Allocation of pins of the Black 16-way SIGMA 2 connector of the passenger compartment harness.

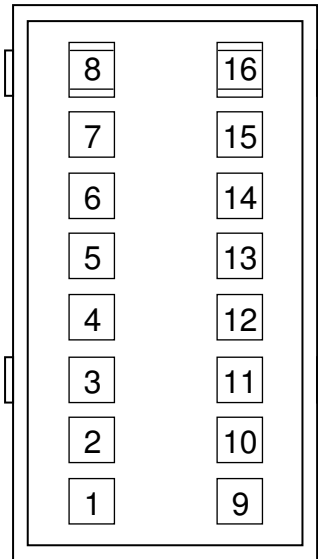

- 8 - Output: Front electric window supply
- 7 - Output: Left hand repeater indicator control
- 6 - Output: Right hand repeater indicator control
- 5 - Output: Rear wiper control
- 4 - Output: Locking motors control
- 3 - Output: Unlocking motors control
- 2 - Output: Heated door mirrors control
- 1 - Output: Heated rear screen control

Выход: Питание шины VAN на в салоне упряжке

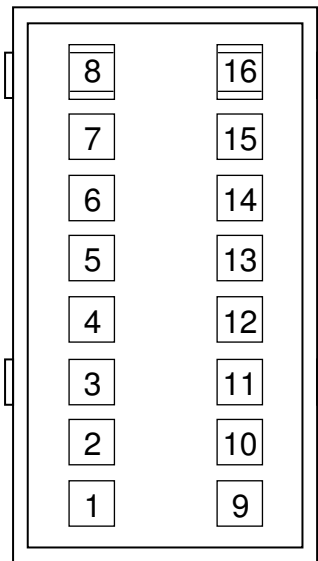

- 16 - Output: Power supply of the VAN bus on passenger compartment harness
- 15 - Output: Rear left hand indicator control
- 14 - Output: Rear right hand indicator control
- 13 - + accessories + после замка AAC
- 12 - Output: Lamps
- 11 - Output: Reversing lamps
- 10 - Output: Deadlocking motors control
- 9 - Output: Heated rear screen control 2

MULTIPLEXED BSI - XSARA PICASSO AND XSARA – PART 1

- Allocation of pins of the Yellow 26-way MQS 26 connector of the main harness.

1	14	1 - K diagnostic line serial connection
2	15	2 - Input: Vehicle speed information
3	16	3 - Input: Engine ECU serial connection for engine immobiliser
4	17	4 - Input: Engine speed information through engine ECU
5	18	5 - Output: Heated rear screen and door mirrors lamp control (except RFTA VAN)
6	19	6 - Output: Engine ECU resupply control for engine immobiliser
7	20	7 - Input: Windscreen wash control
8	21	8 - Input: Wash/wipe control intermittent mode (no rain sensor) auto mode (with rain sensor)
9	22	9 - Output: Low fuel level to engine ECU
10	23	10 - Input: Rear screen wash control
11	24	11 - Input: Rear wiper
12	25	12 - Input: Right hand indicator control
13	26	13 - Input: Windscreen wiper motor parked information
1	14	14 - Input/Output: Battery charge/alternator excitation
2	15	15 - Output: Transponder clock signal
3	16	16 - Output: Engine ECU serial connection for engine immobiliser
4	17	17 - Transponder aerial serial connection for engine immobiliser
5	18	18 - Input: Coolant temperature info by FRIC engine ECU (PWM)
6	19	19 - Input: Windscreen wiper high speed control
7	20	20 - Input: Windscreen wiper slow speed control
8	21	21 - Input: Diesel preheating information
9	22	22 - Input: Inertia switch information
10	23	23 - Input: Coolant temperature warning information through thermoswitch
11	24	24 - Input: Engine ECU fault information
12	25	25 - Input: De-icing button
13	26	26 - Input: Left hand indicator control

MULTIPLEXED BSI - XSARA PICASSO AND XSARA – PART 1

- Allocation of pins of the Brown 12-way MQS connector of the main harness.

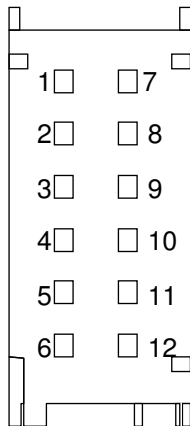

- 1 - Input: On board ECU scroll request
- 2 - Input: Navigation recall last message request
- 3 - For supplier use
- 4 - Output: Headlamp washer relay control
Output: Sidelamp relay control (timed illumination)
- 5 - Output: Air conditioning compressor authorisation request to engine ECU
- 6 - Input: Air conditioning compressor authorisation through engine ECU

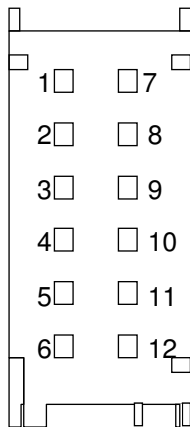

- 7 - Analogue earth
- 8 - Input: Evaporator temperature information
- 9 - Input: Fuel flow information through engine ECU
- 10 - Input: Coolant temperature information through thermistor (analogue)
- 11 - Input: Refrigerant pressure safety information
- 12 - Input: Air conditioning request

- Allocation of pins of the Blue 12-way MQS connector of the passenger compartment.

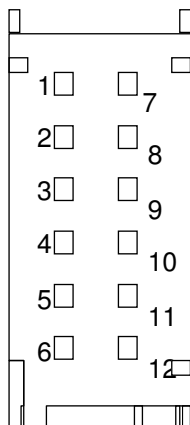

- 1 - Output: Ultra sound module supply
- 2 - Input: Bonnet switch
- 3 - Input/Output: Siren serial connection
- 4 - Output: Close electric windows request when (dead)locking
- 5 - Input: Alarm request through ultrasound module
- 6 - Input: Volumetric suppression request button
- 7 - 12 - Spare

MULTIPLEXED BSI - XSARA PICASSO AND XSARA – PART 1

- Allocation of pins of the Blue 26-way MQS connector of the passenger compartment harness.

1	14	1 - Output: Engine running
2	15	2 - Input: Locking request through lock
3	16	3 - Input: Unlocking request through lock
4	17	4 - Input: Hazard warning lamps request button
5	18	5 - Input: Front right hand door locking button control
6	19	6 - Input: Rear left hand door switch
7	20	7 - Input: Tailgate or boot switch
8	21	8 - Input: Front left hand door locking button control
9	22	9 - Output: System status LED (locking/transponder/alarm function)
10	23	10 - Input: Rear wiper motor parked information
11	24	11 - Input: Front right hand door switch
12	25	12 - Input: Rear right hand door switch
13	26	13 - Input: Front left hand door switch

1	14	14 - Input/Output: Rain sensor serial connection
2	15	15 - Output: Door sill lighting control
3	16	16 - Output: Rear interior lamp control
4	17	17 - Output: Front interior lamp control
5	18	18 - Output: Hazard warning lamps button LED control
6	19	19 - DATA of the SCREEN/COMFORT VAN bus
7	20	20 - Input: External air temperature information
8	21	21 - DATA B of the SCREEN/COMFORT VAN bus
9	22	22 - + ignition on + при зажигании
10	23	23 - + permanent + ПОСТОЯННЫЙ
11	24	24 - Analogue earth of the passenger compartment harness
12	25	25 - Earth
13	26	26 - Earth

MULTIPLEXED BSI - XSARA PICASSO AND XSARA – PART 1

VII - OPERATING MODES

A - NOMINAL MODE OR CUSTOMER MODE

All functions are operational. This is the operating mode designed for normal vehicle use.

B - STAND-BY MODE

In this mode, there is no communications activity and ECU consumption is minimal. The BSI scans its wake-up inputs. Each multiplexed device is able to wake up the network. In each case, it re-supplies all the ECUs by a positive called the +VAN.

ACTION	WAKE-UP NETWORK
IF condition	Ignition on (+accessories or + ignition on)
OR condition	Lamps or hazard warning lamps illuminated
OR condition	HF remote control used
OR condition	Driver's door opened
OR condition	Data B earthed
OR condition	Request to wake-up network by VAN device (radio)

ACTION	SET NETWORK TO STAND-BY
IF condition	Ignition not on
AND condition	No timer
AND condition	No request to maintain network

C - ECONOMY MODE

The BSI cuts the supply to the ECUs (+VAN signal), there are no more communications on the network. Electrical consumption is therefore greatly reduced.

Entry into mode	Engine switched off for more than 30 minutes and +VAN present
Exit from mode	Starting of the engine

Note: A network device can be active and/or communicating, even if it does not appear to be working.

MULTIPLEXED BSI - XSARA PICASSO AND XSARA – PART 1

VIII - AFTER-SALES OPERATIONS, ACCESSORIES

A - GENERAL

In the factory, an initialisation procedure is performed at the end of vehicle assembly in order to allow the various devices to recognise each other:

- ignition key with integrated transponder and BSI,
- HP remote controls and BSI,
- engine management ECU and BSI,
- radio and BSI.

B - ACCESSORIES

All new devices which have not undergone a programming procedure are not recognised by the system and are therefore not operational. It is therefore essential to declare all accessories which are added to or removed from the vehicle. All programming procedures require the use of a diagnostic tool. They must be performed on the vehicle.

Note: The multiplexed self-powered alarm must be disconnected when performing a diagnostic procedure on the vehicle.

	ACCESSORIES	PROGRAMMING IF ADDING/REMOVING
XSARA PICASSO	CD changer	YES > Programming of the control panel
	Alarm	YES > Deactivation of signalling when locking: BSI programming
XSARA	Accessory alarm	YES > BSI programming + deactivation of signalling when locking

C - CUSTOMISATION OF CERTAIN FUNCTIONS

Upon the customer's request, the BSI can be programmed to activate the function or not.

Radio volume linked to vehicle speed: Programming of the radio.

MULTIPLEXED BSI - XSARA PICASSO AND XSARA – PART 1

D - REPLACEMENT OPERATIONS

1 - Customer confidential card

The access code (4 characters) is given to the customer on a confidential card. It can be seen after removing the masking strip on the card. It is required for all maintenance procedures on the system.

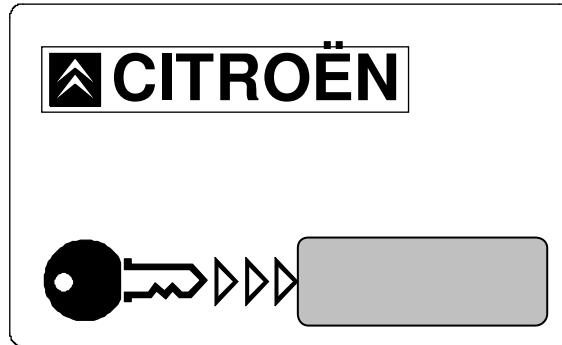

IMPORTANT: Before adding or replacing parts, ensure that the customer is still in possession of his confidential card.

2 - Loss of access code

The access code is linked to a chassis number and managed by the CITROËN network.

3 - Ordering parts

PART TO BE ORDERED	TO BE OBTAINED FROM THE CUSTOMER	TO BE SUPPLIED
BSI	confidential card vehicle registration document form of identity faulty BSI	BSI access code vehicle VIN code
Engine ECU	confidential card vehicle registration document form of identity Faulty engine ECU	BSI access code vehicle VIN code
Key with integrated transponder	1 key	mechanical key code
Key with integrated transponder and HF remote control	1 key	mechanical key code

MULTIPLEXED BSI - XSARA PICASSO AND XSARA – PART 1

4 - Repairs

ITEM TO BE REPLACED	ESSENTIAL ITEMS	OPERATIONS TO BE PERFORMED
BSI ONLY *	Customer's confidential card. All vehicle keys. New BSI. Diagnostic tool.	Programming of access code. Programming of keys and HF remote controls.
ENGINE ECU ONLY	Customer's confidential card. New engine ECU. Diagnostic tool.	Programming of engine ECU code.
KEYS AND/OR REMOTE CONTROLS	Customer's confidential card. All vehicle keys. Diagnostic tool.	Programming of keys and HF remote controls.
BSI * + ENGINE ECU	Customer's confidential card. All vehicle keys. New BSI + engine ECU. Diagnostic tool.	Programming of access code. Programming of keys and/or HF remote controls. Programming of engine ECU code.

* Remember to configure the BSI according to the correct customisation of the functions and accessories fitted on the vehicle.

5 - Interchanging parts

WARNING: Interchanging the BSI and engine ECU with one (or several) components from a different vehicle is strictly forbidden.

The transponder keys, HF remote controls, BSI and engine ECU are linked to the vehicle's VIN.

E - DIAGNOSTIC

The BSI acts as a gateway for the diagnostic tool which is used to identify the faults in certain components of the system.

A fault may be:

- a short circuit to earth or to +12V,
- an open circuit (broken wire),
- an operating fault (invalid value sent by a sensor),
- an ECU which no longer communicates on the network: network isolated or faulty ECU.

MULTIPLEXED BSI - XSARA PICASSO AND XSARA – PART 1

Below is a list of faults which can be returned by the BSI on the XSARA and the XSARA PICASSO:

FAULT	XSARA	XSARA PICASSO
+Accessories stuck on 0	X	X
Ultrasound unit supply - short circuit to earth	X	
Alternator	X	X
+ignition on stuck on 0	X	X
Rain sensor	X	
Air conditioning – Air conditioning compressor - Authorisation	X	X
De-icing - Lamp output short circuited to earth	X	X
Lighting - right hand indicators	X	X
Lighting - left hand indicators	X	X
Engine ECU - error code received	X	X
Engine ECU - reception fault	X	X
Engine ECU - Relays - Short circuited to earth	X	X
Engine ECU or EOBD	X	X
Hazard warning lamps - Input (request) stuck on 1	X	X
Hazard warning lamps - Button LED - Short circuited to earth	X	X
Low fuel - Short circuited to +BAT	X	X
Plip - battery in current key worn	X	X
EEPROM problem	X	X
Engine speed	X	X
Locking motors - Permanent request from ignition key	X	X
Unlocking motors - Permanent request from ignition key	X	X
Siren	X	
Evaporator sensor - Short circuit	X	X
Coolant temperature	X	X
Transponder - Short circuit on connection with ring	X	X
Transponder - Identification	X	X
COMFORT VAN - BSI mute	X	X
COMFORT VAN - Air conditioning mute	X	X
COMFORT VAN - Communication on Data	X	X
COMFORT VAN - Communication on Data B	X	X
COMFORT VAN - Multifunction screen mute	X	X
COMFORT VAN - Wake-up by network prohibited due to short circuit on Data B		X
Vehicle speed - invalid value or sensor connection problem	X	X
System status lamp - Short circuited to +BAT	X	X
COMFORT VAN – Communications fault counter on DATA		X
COMFORT VAN – Communications fault counter on DATA B		X
COMFORT VAN – Frames not sent counter - BSI mute		X
COMFORT VAN – Control panel counter missing		X
COMFORT VAN – Multifunction screen counter missing		X
COMFORT VAN – Air conditioning counter missing		X

MULTIPLEXED BSI - XSARA PICASSO AND XSARA – PART 1

II - PARTS LIST

- BB00 - Battery
- BB12 - + battery connection terminal
- BH12 - 12 fuse box (passenger compartment)
- BH28 - 28 fuse box (passenger compartment)
- BM34 - 34 fuse engine relay unit
- BSI1 - Built-in systems interface
- C001 - Diagnostic connector
- CA00 - Ignition switch
- CT00 - Rotary connector
- 0002 - Signalling/lighting stalk
- 0004 - Control panel
- 0005 - Wiper stalk
- 1010 - Starter motor
- 1020 - Alternator
- 1203 - Inertia switch
- 1211 - Fuel sender pump
- 1220 - Engine coolant temperature sensor
- 1313 - Engine speed sensor
- 1320 - Engine management ECU
- 1620 - Vehicle speed sensor
- 2300 - Danger signal switch
- 2340 - Left hand side repeater
- 2345 - Right hand side repeater
- 2610 - Left hand headlamp
- 2615 - Right hand headlamp
- 2630 - Rear left hand lamp on body
- 2635 - Rear right hand lamp on body
- 3010 - Front interior lamp
- 3020 - Rear interior lamp
- 3050 - Lighting rheostat
- 3054 - Ashtray lighting
- 3105 - Boot (or tailgate) lighting

MULTIPLEXED BSI - XSARA PICASSO AND XSARA – PART 1

- 3110 - Glove box lighting switch
- 3115 - Glove box lighting
- 4010 - Engine coolant level switch
- 4025 - Temperature sensor - engine coolant thermostats (gauge)
- 5015 - Windscreen wiper motor
- 5115 - Windscreen/rear screen washer pump
- 6202 - Front door lock assembly driver's side
- 6207 - Front door lock assembly passenger's side
- 6260 - Boot locking motor
- 8006 - Evaporator thermistor (if separate)
- 8007 - Pressure switch
- 8008 - Air conditioning engine coolant temperature thermistor
- 8010 - Coolant temperature unit
- 8020 - Air conditioning compressor
- 8025 - Air conditioning control panel (if separate)
- 8030 - Passenger compartment air thermistor
- 8031 - Coolant thermistor
- 8045 - Blower control module (if separate)
- 8050 - Blower motor (if separate)
- 8065 - Mixing flap reduction motor
- 8070 - Air input flap reduction motor
- 8071 - Distribution flap reduction motor
- 8220 - Analogue module transponder
- 8410 - Radio
- 8413 - Radio control
- 8415 - Compact disc changer
- 8420 - Loud speakers on front door (driver's side)
- 8425 - Loud speakers on front door (passenger's side)
- 8430 - Loud speaker (rear left hand)
- 8435 - Loud speaker (rear right hand)
- 8440 - Front left hand tweeter speaker
- 8445 - Front right hand tweeter speaker
- 8500 - Navigation ECU

MULTIPLEXED BSI - XSARA PICASSO AND XSARA – PART 1

MULTIPLEXED BSI - XSARA PICASSO AND XSARA – PART 1

PART 2

SIGNALLING

XSARA AND XSARA PICASSO

MULTIPLEXED BSI - XSARA PICASSO AND XSARA – PART 2

GENERAL

I - FOREWORD



The left and right hand indicators and side repeaters can be controlled simultaneously or independently in the following order of priority:

1	Automatic illumination of hazard warning lamps in the event of an impact (XSARA PICASSO only).
2	Locking / unlocking using the HF remote control or the key.
3	Hazard warning lamps.
4	Indicators.

The BSI incorporates the flasher unit and the internal relays. The indicators are therefore connected DIRECTLY to an output of the BSI. The LEDs and buzzer on the control panel are activated through the Comfort VAN network.

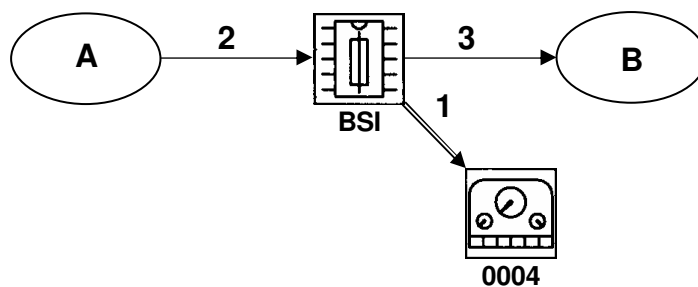
II - GENERAL LAYOUT



Key:  single arrow = wire connection
 triple arrow = multiplexed connection

MULTIPLEXED BSI - XSARA PICASSO AND XSARA – PART 2

COMPONENTS	
BSI	Built-in Systems Interface
0004	Control panel
A	Steering wheel stalk
	Hazard warning lamps button
	Inertia switch
B	Indicators and side repeaters
	Hazard warning lamps button LED

CONNECTIONS		
N°	SIGNAL	TYPE
1	Control of the lamp and buzzer	VAN
2	Indicators activation request	All or Nothing
	Hazard warning lamps activation request	All or Nothing
	Impact detection	All or Nothing
3	Indicators and side repeaters control	All or Nothing
	Hazard warning lamps button LED control	All or Nothing

MULTIPLEXED BSI - XSARA PICASSO AND XSARA – PART 2

OPERATING PRINCIPLE

I - INDICATOR FUNCTION

Function

The BSI controls the direction indicators, the side repeaters and the LEDs on the control panel.

Functional description

The driver's request is acquired by the right or left hand indicator contacts when the ignition is on.

II - HAZARD WARNING LAMPS FUNCTION

A - ILLUMINATION OF THE HAZARD WARNING LAMPS BY PRESSING THE HAZARD WARNING LAMPS BUTTON

Function:

The BSI controls the direction indicators, the side repeaters, the danger signal warning LED and the LEDs on the control panel.

Functional description:

The driver's request is acquired by the hazard warning lamps button contact, located on the instrument panel. The function can always be activated, whether the ignition is on or off, except for the LEDs on the control panel which are only activated if the + accessories or + ignition are on.

Note: Pressing this button can wake up the VAN network.

Display:

The danger warning LED is activated by connecting an output of the BSI to +BAT.

The LED on the control panel will not be activated if the + accessories is not on.

MULTIPLEXED BSI - XSARA PICASSO AND XSARA – PART 2

B - AUTOMATIC ILLUMINATION OF HAZARD WARNING LAMPS IN THE EVENT OF AN IMPACT

Note: This function is only available on the XSARA PICASSO

Function:

The BSI controls the hazard warning lamps when an impact is detected.

Functional description:

Action	Illumination of hazard warning lamps.
IF condition	the ignition is on
AND condition	the impact detection input is activated (connected to +BAT).

The impact is detected by the inertia switch mounted on a rigid part of the vehicle's structure (mechanical switch). The hazard warning lamps can be switched off after an impact by pressing the button.

Note: This function is not totally reliable. It depends on the size and type of the impact. The fact that the hazard warning lamps have illuminated in the event of an impact should therefore not be communicated.

III - FAULTY BULB DETECTION FUNCTION

Function:

The aim of this function is to double the illumination frequency of the indicators (left or right hand) if at least one blown bulb is detected.

Functional description:

Detection is performed whilst the indicators and side repeaters (left or right hand) are operating, by reading the control current of the indicators.

If the current supplied by the BSI is greater than the current consumed by an indicator or a side repeater bulb, operation is normal. If not, the illumination frequency is doubled.

All operating faults are recorded by the BSI so that they can be read by the diagnostic tool.

Note: When a tow bar is fitted, 2 bulbs must have blown for detection to occur.

MULTIPLEXED BSI - XSARA PICASSO AND XSARA – PART 2

ELECTRICITY

I - LAYOUT DIAGRAM

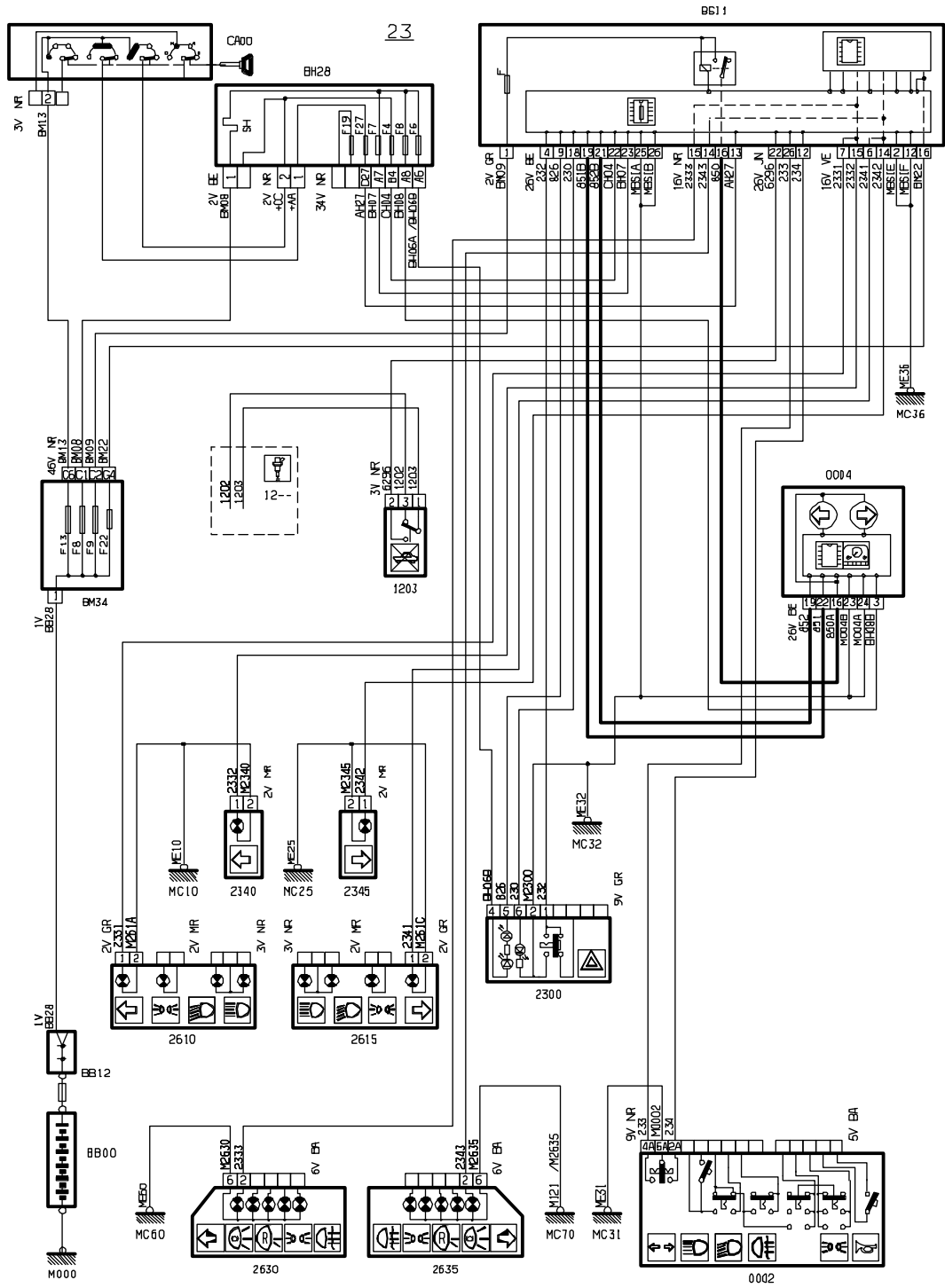

PFM002P

MULTIPLEXED BSI - XSARA PICASSO AND XSARA – PART 2

II - PARTS LIST

- BB00 - Battery
- BB12 - + battery connection terminal
- BH12 - 12 fuse box (passenger compartment)
- BH28 - 28 fuse box (passenger compartment)
- BM34 - 34 fuse engine relay unit
- BSI1 - Built-in systems interface
- C001 - Diagnostic connector
- CA00 - Ignition switch
- CT00 - Rotary connector
- 0002 - Signalling/lighting stalk
- 0004 - Control panel
- 0005 - Wiper stalk
- 1010 - Starter motor
- 1020 - Alternator
- 1203 - Inertia switch
- 1211 - Fuel sender pump
- 1220 - Engine coolant temperature sensor
- 1313 - Engine speed sensor
- 1320 - Engine management ECU
- 1620 - Vehicle speed sensor
- 2300 - Danger signal switch
- 2340 - Left hand side repeater
- 2345 - Right hand side repeater
- 2610 - Left hand headlamp
- 2615 - Right hand headlamp
- 2630 - Rear left hand lamp on body
- 2635 - Rear right hand lamp on body
- 3010 - Front interior lamp
- 3020 - Rear interior lamp
- 3050 - Lighting rheostat
- 3054 - Ashtray lighting
- 3105 - Boot (or tailgate) lighting

MULTIPLEXED BSI - XSARA PICASSO AND XSARA – PART 2

- 3110 - Glove box lighting switch
- 3115 - Glove box lighting
- 4010 - Engine coolant level switch
- 4025 - Temperature sensor - engine coolant thermostats (gauge)
- 5015 - Windscreen wiper motor
- 5115 - Windscreen/rear screen washer pump
- 6202 - Front door lock assembly driver's side
- 6207 - Front door lock assembly passenger's side
- 6260 - Boot locking motor
- 8006 - Evaporator thermistor (if separate)
- 8007 - Pressure switch
- 8008 - Air conditioning engine coolant temperature thermistor
- 8010 - Coolant temperature unit
- 8020 - Air conditioning compressor
- 8025 - Air conditioning control panel (if separate)
- 8030 - Passenger compartment air thermistor
- 8031 - Coolant thermistor
- 8045 - Blower control module (if separate)
- 8050 - Blower motor (if separate)
- 8065 - Mixing flap reduction motor
- 8070 - Air input flap reduction motor
- 8071 - Distribution flap reduction motor
- 8220 - Analogue module transponder
- 8410 - Radio
- 8413 - Radio control
- 8415 - Compact disc changer
- 8420 - Loud speakers on front door (driver's side)
- 8425 - Loud speakers on front door (passenger's side)
- 8430 - Loud speaker (rear left hand)
- 8435 - Loud speaker (rear right hand)
- 8440 - Front left hand tweeter speaker
- 8445 - Front right hand tweeter speaker
- 8500 - Navigation ECU

MULTIPLEXED BSI - XSARA PICASSO AND XSARA – PART 2

PART 3

INTERIOR LIGHTING

XSARA AND XSARA PICASSO

MULTIPLEXED BSI - XSARA PICASSO AND XSARA – PART 3

MULTIPLEXED BSI - XSARA PICASSO AND XSARA – PART 3

GENERAL

I - FOREWORD

The interior lighting consists of 2 interior lamps. They are activated by:

- the 4 vehicle doors,
- the tailgate on the XSARA PICASSO,
- the interior lamp switches.

Positions of an interior lamp switch:

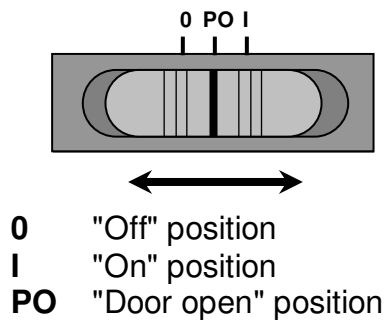

Progressive illumination and extinguishing of the interior lamps

The interior lamps always illuminate and extinguish progressively. The aim of this function is to protect passengers against a sudden change in lighting.

Layout diagram:

Below is the illumination and extinguishing cycle for each interior lamp:

- transitions to an illuminated state have priority,
- progressive illumination / extinguishing transitions are possible,
- there is no perceptible discontinuity.

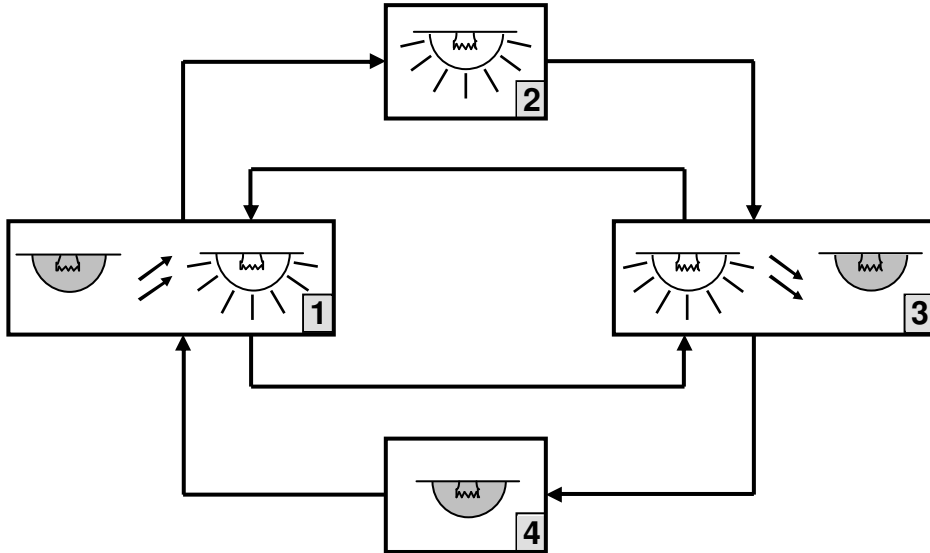



KEY	
1	Progressive illumination of interior lamp
2	Interior lamp illuminated
3	Progressive extinguishing of interior lamp
4	Interior lamp extinguished

ACTION	TIMER
Progressive illumination	1 second
Progressive extinguishing	4 seconds

MULTIPLEXED BSI - XSARA PICASSO AND XSARA – PART 3

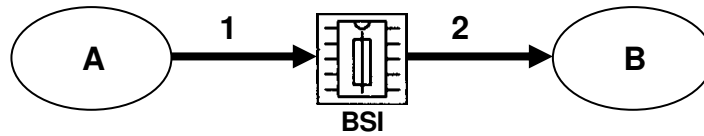
II - GENERAL LAYOUT



Key:  single arrow = wire connection
 triple arrow = multiplexed connection

COMPONENTS	
BSI	Built-in Systems Interface
A	Switches of the 4 doors (and tailgate on the Xsara Picasso). Interior lamp switches Ignition switch
B	Front and rear interior lamps

CONNECTIONS		
N°	SIGNAL	TYPE
1	Status of doors/tailgate	All or Nothing
	Change of interior lamp status request	-----
	Presence of ignition key	All or Nothing
	Presence of + accessories	All or Nothing
2	Timed illumination control	Analogue

MULTIPLEXED BSI - XSARA PICASSO AND XSARA – PART 3

MULTIPLEXED BSI - XSARA PICASSO AND XSARA – PART 3

OPERATING PRINCIPLE

Interior lamp timer

Function:

To control:

- the illumination duration of the interior lamps (10 minutes or 10 seconds),
- the extinguishing of the interior lamps.

Functional description:

	10 minute timer		10 second timer			Extinguishing								
Door/tailgate status	X	opening	X	X	closing	X	closed	closed	closed	closing	closed	closed	closed	X
+ accessories	X	X	X	X	missing	X	+ ACC on	X	X	present	X	X	X	X
Locking	X	X	X	X	X	X	X	yes	X	X	X	X	X	X
Unlocking	X	X	yes	X	X	X	X	X	X	X	X	X	X	X
Switch position	X→a	X	X	X	b	X	b	b	b	b	a→b	a→c	X	X
Removal of ignition key	X	X	X	yes	X	X	X	X	X	X	X	X	X	X
10 second timer	X	X	X	X	X	no	X	X	end	X	X	X	X	X
10 minute timer	X	X	X	X	X	end	X	X	no	X	X	X	X	X
Economy mode	no	no	no	no	X	X	X	X	X	X	X	X	X	Entry into mode

X = Neutral status.

MULTIPLEXED BSI - XSARA PICASSO AND XSARA – PART 3

MULTIPLEXED BSI - XSARA PICASSO AND XSARA – PART 3

ELECTRICITY

I - LAYOUT DIAGRAM

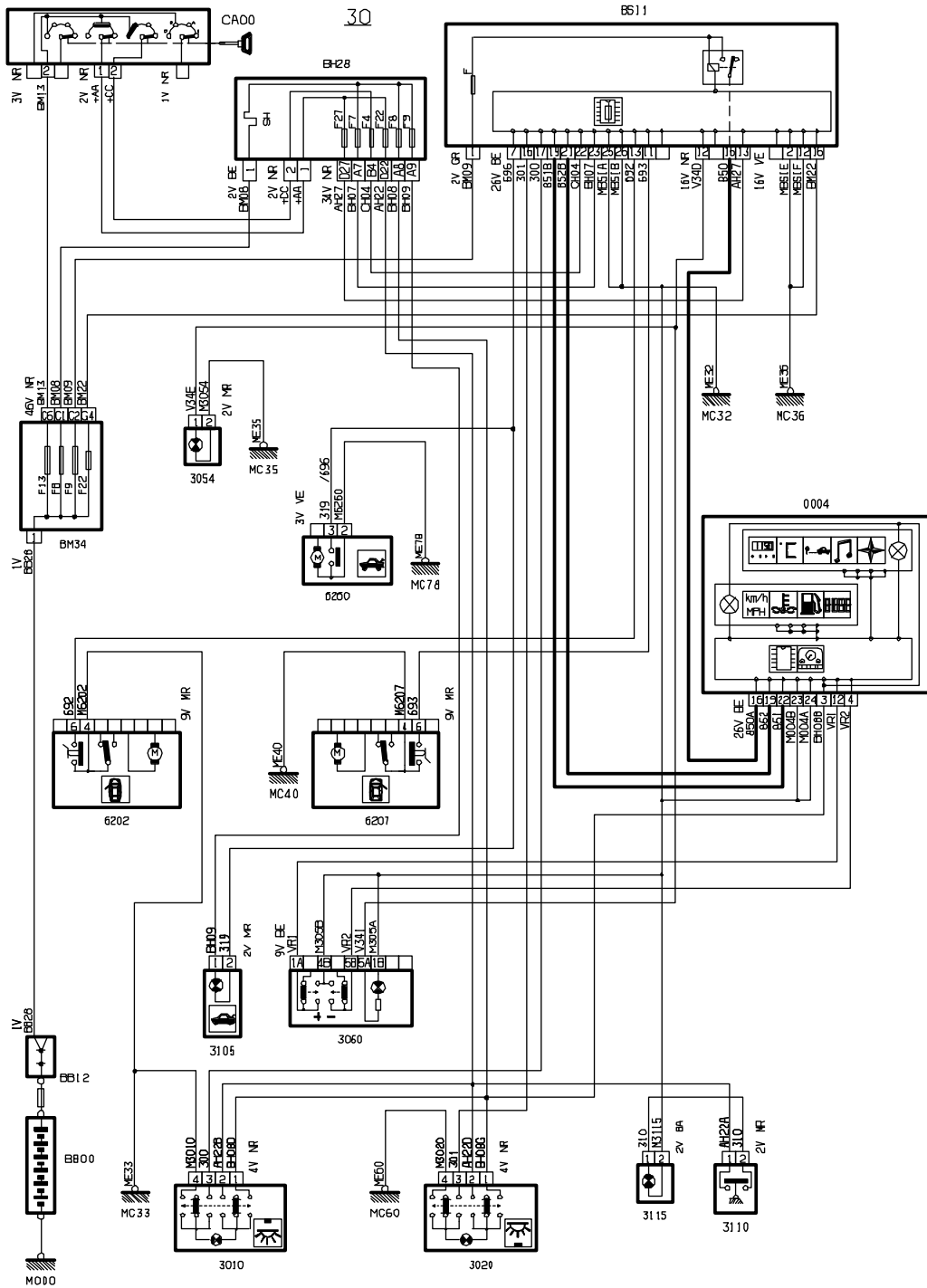

PFM003P

MULTIPLEXED BSI - XSARA PICASSO AND XSARA – PART 3

II - PARTS LIST

- BB00 - Battery
- BB12 - + battery connection terminal
- BH12 - 12 fuse box (passenger compartment)
- BH28 - 28 fuse box (passenger compartment)
- BM34 - 34 fuse engine relay unit
- BSI1 - Built-in systems interface
- C001 - Diagnostic connector
- CA00 - Ignition switch
- CT00 - Rotary connector
- 0002 - Signalling/lighting stalk
- 0004 - Control panel
- 0005 - Wiper stalk
- 1010 - Starter motor
- 1020 - Alternator
- 1203 - Inertia switch
- 1211 - Fuel sender pump
- 1220 - Engine coolant temperature sensor
- 1313 - Engine speed sensor
- 1320 - Engine management ECU
- 1620 - Vehicle speed sensor
- 2300 - Danger signal switch
- 2340 - Left hand side repeater
- 2345 - Right hand side repeater
- 2610 - Left hand headlamp
- 2615 - Right hand headlamp
- 2630 - Rear left hand lamp on body
- 2635 - Rear right hand lamp on body
- 3010 - Front interior lamp
- 3020 - Rear interior lamp
- 3050 - Lighting rheostat
- 3054 - Ashtray lighting
- 3105 - Boot (or tailgate) lighting

MULTIPLEXED BSI - XSARA PICASSO AND XSARA – PART 3

- 3110 - Glove box lighting switch
- 3115 - Glove box lighting
- 4010 - Engine coolant level switch
- 4025 - Temperature sensor - engine coolant thermostats (gauge)
- 5015 - Windscreen wiper motor
- 5115 - Windscreen/rear screen washer pump
- 6202 - Front door lock assembly driver's side
- 6207 - Front door lock assembly passenger's side
- 6260 - Boot locking motor
- 8006 - Evaporator thermistor (if separate)
- 8007 - Pressure switch
- 8008 - Air conditioning engine coolant temperature thermistor
- 8010 - Coolant temperature unit
- 8020 - Air conditioning compressor
- 8025 - Air conditioning control panel (if separate)
- 8030 - Passenger compartment air thermistor
- 8031 - Coolant thermistor
- 8045 - Blower control module (if separate)
- 8050 - Blower motor (if separate)
- 8065 - Mixing flap reduction motor
- 8070 - Air input flap reduction motor
- 8071 - Distribution flap reduction motor
- 8220 - Analogue module transponder
- 8410 - Radio
- 8413 - Radio control
- 8415 - Compact disc changer
- 8420 - Loud speakers on front door (driver's side)
- 8425 - Loud speakers on front door (passenger's side)
- 8430 - Loud speaker (rear left hand)
- 8435 - Loud speaker (rear right hand)
- 8440 - Front left hand tweeter speaker
- 8445 - Front right hand tweeter speaker
- 8500 - Navigation ECU

MULTIPLEXED BSI - XSARA PICASSO AND XSARA – PART 3

PART 4

DRIVER'S INFORMATION XSARA PICASSO

MULTIPLEXED BSI - XSARA PICASSO AND XSARA – PART 4

GENERAL

I - FOREWORD

This function is shared between four sub-functions:



- Instrumentation function,
- Messages and Warnings function,
- Lighting function,
- On-board ECU function.

The control panel is at the centre of the Driver's Information function. The basic control panel (type B) is described in this section.

II - LAYOUT

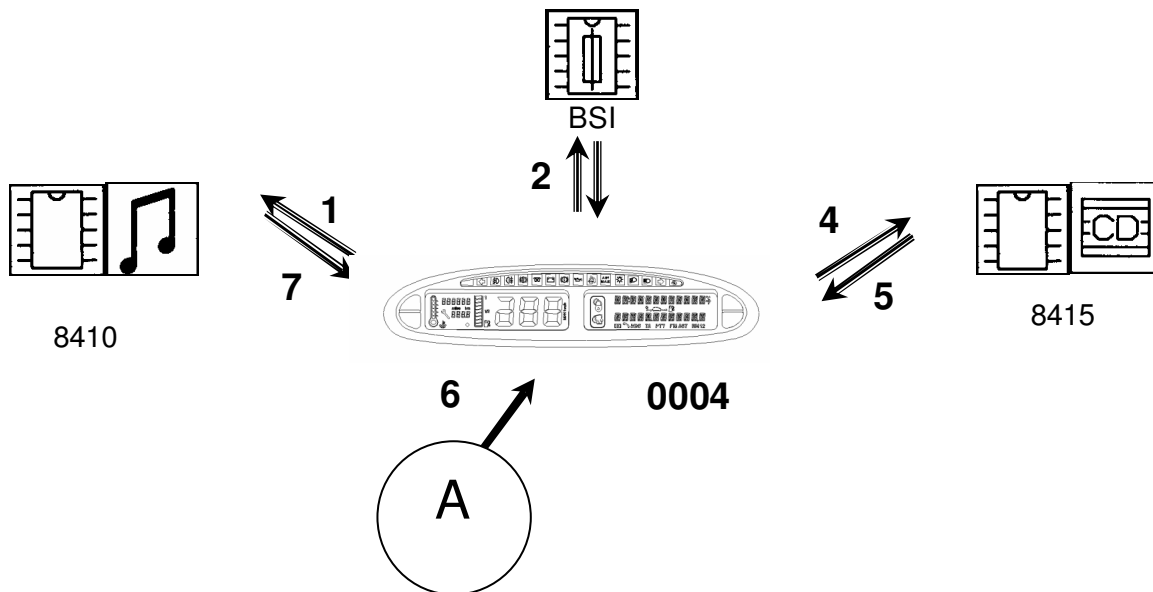
The control panel receives information along the wires and by communicating with the ECUs via the VAN network.



Key:  single arrow = wire connection
 double arrow = multiplexed connection

COMPONENTS	
BSI	Built-in Systems Interface
0004	Control panel / MFS (LEDs + microprocessor)
8410	Radio
8415	CD changer available as an option
A	pressure switch
	electrodes
	Parking brake switch
	Steering wheel stalk
	Airbag ECUs
	Fuel sender
	Child safety switch
	ABS valve block
	Brake fluid gauge
	+ rheostat button
	- rheostat button

MULTIPLEXED BSI - XSARA PICASSO AND XSARA – PART 4

A - INPUTS TO THE CONTROL PANEL/MULTIFUNCTION SCREEN (MFS)

Wire inputs

DESCRIPTION	ORIGIN	TYPE	N°
Low coolant level	Level sensor	All or nothing	6
Parking brake status	Switch	All or nothing	
Mainbeam status	Steering wheel stalk	All or nothing	
Dipped beam status	Steering wheel stalk	All or nothing	
Side airbags fault	Side airbags ECUs	All or nothing	
Front airbag fault and passenger's airbag status	Airbag ECU	All or nothing and frequency depending on fault	
Fuel level	Fuel sender	Analogue	
RH and LH child safety	Child safety switch	All or nothing	
ABS fault	ABS valve block	Lamp active	
Electronic brakeforce distributor fault	ABS valve block	All or nothing	
Radio and CD changer status change request	Steering wheel stalk	All or nothing Analogue	
Front and rear fog lamps control	Steering wheel stalk	All or nothing	
Brake fluid level	Brake fluid gauge	All or nothing	
Increase brightness	Rheostat	All or nothing	
Decrease brightness	Rheostat	All or nothing	
Min oil pressure	Pressure sensor	All or nothing	

MULTIPLEXED BSI - XSARA PICASSO AND XSARA – PART 4

Multiplexed inputs

BSI ⇒ CONTROL PANEL MFS

Fast BSI data

DESCRIPTION	N°
Engine speed	3
Instantaneous vehicle speed	
Distance travelled	
Fuel consumption	

Slow BSI data

DESCRIPTION	N°
Day / night status	3
Night driving mode	
Control panel brightness level	
(Alarm on stand-by)	
Factory / Customer mode	
Reverse gear	
Economy mode	
Set to stand-by within 5 seconds	
Engine running	
Position of ignition key	
Coolant temperature	
Vehicle mileometer	
External temperature	

BSI configuration

DESCRIPTION	N°
VIN	3

MULTIPLEXED BSI - XSARA PICASSO AND XSARA – PART 4

BSI display

DESCRIPTION	N°
Coolant temperature warning	3
Brake fluid / hydraulic level warning	
Door(s) open warning, engine running	
Oil pressure warning	
Electronic brakeforce distributor (EBD) fault	
ABS fault	
EOBD fault	
Battery charge fault	
Headlamps left on reminder warning signal	
Key left in ignition reminder warning signal	
Overspeed warning signal	
Parking brake	
HF plip battery worn	
Impact sensor warning signal	
Electric engine immobiliser system fault	
Vehicle locking status	

BSI events

DESCRIPTION	N°
Main event present	3
Secondary event present	
Source of the event	
Change of signals and modes	
Change of door status	
Change of on board ECU data	

MULTIPLEXED BSI - XSARA PICASSO AND XSARA – PART 4

Additional BSI display

DESCRIPTION	N°
Front right hand door open	3
Front left hand door open	
Rear right hand door open	
Rear left hand door open	
Boot open	
Consumption invalid (flowmeter fault)	
Range invalid (sender fault)	
Range calculation impossible (fuel level too low)	
Distance travelled insufficient (less than 400 m since resetting)	
Journey distance insufficient (less than 400 m since resetting)	
Status of on board ECU scroll button	
Average speed travelled	
Average journey speed	
Filtered speed	
Cumulative distance travelled	
Average consumption	
Cumulative journey distance	
Average journey consumption	
Instantaneous consumption	
Remaining range	

Control panel functions

DESCRIPTION	N°
Activation of control panel	3
Pre-heating	
Hazard warning lamps LED	
Right hand indicator	
Left hand indicator	

MULTIPLEXED BSI - XSARA PICASSO AND XSARA – PART 4

CD changer ⇒ CONTROL PANEL/MFS

DESCRIPTION	N°
CD changer event	5
CD changer status	

Radio ⇒ CONTROL PANEL/MFS

DESCRIPTION	N°
Radio event	7
General radio status	
Specific radio status	

Multiplexed outputs

Control panel/MFS ⇒ BSI

Control panel status

DESCRIPTION	N°
Oil pressure warning	7
Night driving mode	
Parking brake	
Control panel brightness level	
Low fuel information	
ABS fault	
Electronic brakeforce distributor (EBD) fault	
Brake fluid fault	
Automatic gearbox fault	
Gross fuel level	
Dipped beam	

Control panel reading

DESCRIPTION	N°
Saved mileage	2

MULTIPLEXED BSI - XSARA PICASSO AND XSARA – PART 4

MFS request

DESCRIPTION	N°
Request to reset cumulative distance	2
Request to reset cumulative journeys	
Request to maintain + comfort VAN	

MFS/CONTROL PANEL ⇒ radio

DESCRIPTION	N°
Radio control	1

MFS/CONTROL PANEL ⇒ CD changer

DESCRIPTION	N°
CD changer control	4

III - XSARA PICASSO CONTROL PANEL

A - FUNCTION

The control panel has the following functions:

- Acquisition of information from the sensors and VAN network,
- Sending of data on the VAN network,
- Display of on board ECU parameters on the multifunction screen (type B),
- Warning to the driver of the vehicle status (noise, message, maintenance information, LEDs),
- Operation of radio and CD changer,
- Storing of distance travelled,
- Overspeed detection.

B - GENERAL DESCRIPTION

The control panel consists of the following components:

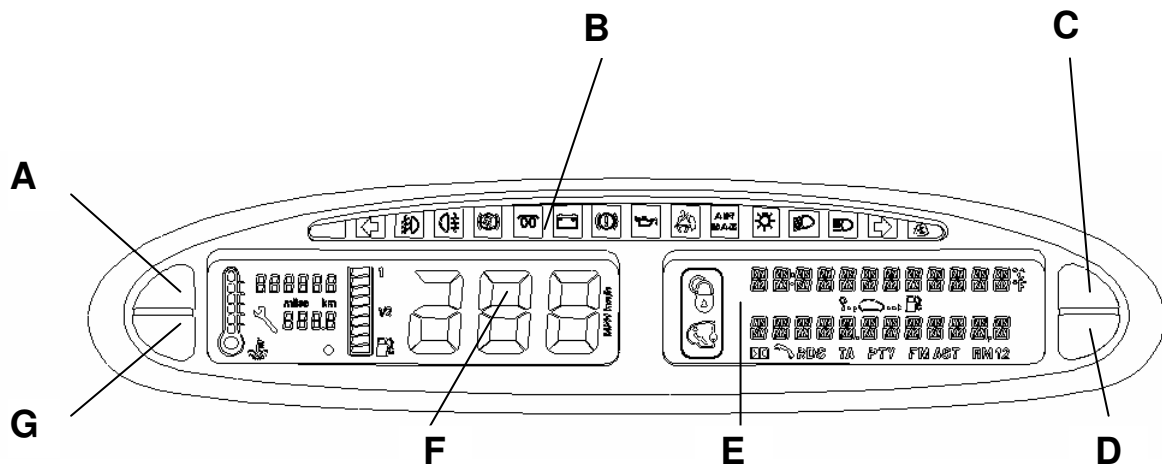

- Strip of LEDs; zone "b",
- Instrumentation screen; zone "f",
- Multifunction screen, type B; zone "e",
- Integrated buzzer,
- "Night driving" push button; button "a",
- "Tripometer" reset push button; button "g",
- "Access to adjustment menu" push button; button "c",
- "Incrementation in adjustment menu" push button; button "d"

MULTIPLEXED BSI - XSARA PICASSO AND XSARA – PART 4

C - LEDS

The control panel contains the following strip of LEDs:

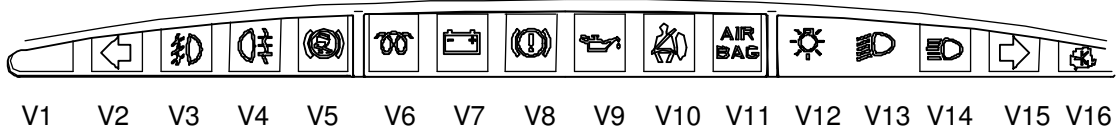

LED	FUNCTION
V1	Not used
V2	Left hand indicator LED
V3	Front fog lamp
V4	Rear fog lamp
V5	ABS fault
V6	Diesel pre-heating
V7	Battery charge
V8	Brake fault
V9	Oil pressure
V10	Diagnostic: side AIRBAG
V11	Front AIRBAG + pyrotechnic seatbelts diagnostic or passenger AIRBAG deactivated
V12	Headlamps
V13	Dipped beam
V14	Main beam
V15	Right hand indicator LED
V16	Engine management LED

D - INSTRUMENTATION SCREEN

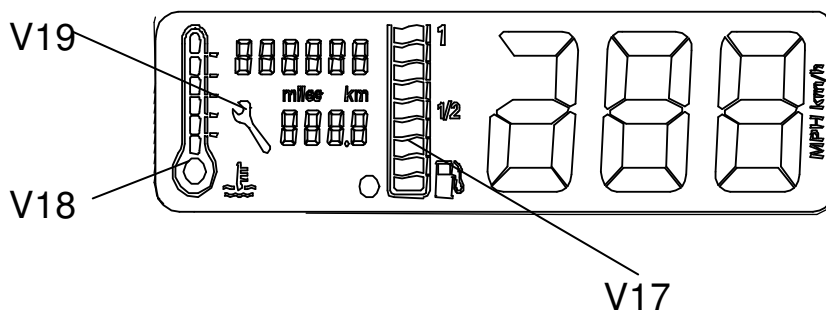

The instrumentation screen includes:

- A speedometer,
- A mileometer (incorporating the main mileometer, tripometer and maintenance indicator LED V19 functions),
- A coolant temperature gauge with a coolant temperature warning (LED V18),
- A fuel level gauge with a low fuel warning (LED V17).

MULTIPLEXED BSI - XSARA PICASSO AND XSARA – PART 4

E - MULTIFUNCTION SCREEN, TYPE B

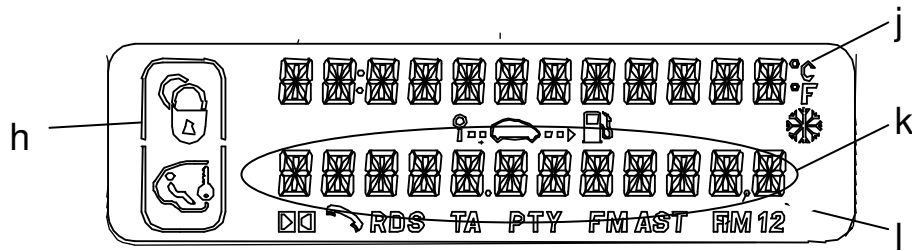

The display is divided into four zones:

Zone "j": display of the time and external temperature and other messages,

Zone "k": display of the audio, CD changer and on board ECU settings,

Zone "h": display of the "central locking" and "child safety" symbols,

Zone "l": display of the symbols linked to the radio information.

The functions associated to the multifunction screen B are:

- Display of the time, date and external temperature,
- Display of the information linked to the radio and CD changer,
- On board ECU,
- Vehicle warnings.

F - INTEGRATED BUZZER

The buzzer integrated into the control panel produces 5 types of sound:

- "Flashing" type sound **D1**,
- "Overspeed" type 2 tone sound **D2.a**,
- "Headlamps left on" type 2 tone sound **D2.b**,
- "Key left in ignition" type 3 tone sound **D2.c**,
- "Warning beep" type sound **D3**.

A sound is emitted in the following situations:

- when certain messages appear on the multifunction screen,
- when certain LEDs illuminate,
- when a warning not associated to a message or an LED appears.

MULTIPLEXED BSI - XSARA PICASSO AND XSARA – PART 4

MESSAGES AND WARNINGS FUNCTION

I - DISPLAY

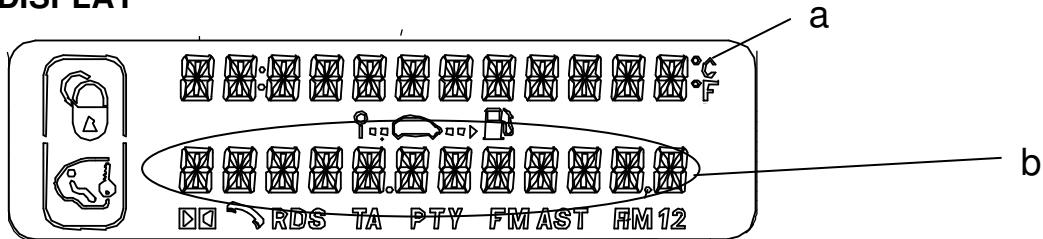

Long messages are displayed in two stages in zones "a" and "b". Sequence 1 (called SEQ1) is displayed followed by sequence 2 (called SEQ2).

The time for which the messages are displayed depends on their appearance priority.

II - PRIORITY LEVELS

Three display priorities are defined for warnings on the control panel:

- P0: Warning which cannot be acknowledged by the driver, displayed until the fault disappears or the ignition is switched off,
- P1: Warning which can be acknowledged by the driver, displayed until the fault disappears or the ignition is switched off or by pressing one of the buttons on the control panel,
- P2: Timed warning, displayed until the fault disappears or the ignition is switched off or the end of the 6 second timer or by pressing one of the buttons on the control panel. This degree of priority is only valid if the associated warning is unique.

III - WARNINGS FROM WIRE INFORMATION

TYPE OF WARNING	SEQ	ASSOCIATED MESSAGE		LED PRIORITY; BUZZER	APPEARANCE CONDITIONS
		ZONE "a"	ZONE "b"		
Brake fluid / hydraulic level warning	1 2	TOP_UP	BRAKE_FLUID	P1;V8;D3 single sound	+ig on* (V≥0) AND fluid level low
Oil pressure warning	1 2	STOP OIL_PRESSURE	LOW	P1;V9;D3* repetitive sound	+ig on* AND Oil pressure low
Brake distributor fault		WARNING	BRAKE_FAULT	P1;V8;D3 single sound	+ig on* AND braking system faulty
Passenger's AIRBAG deactivated				P1;V11;D3 single sound	+ig on* (V≥0) AND passenger's airbag deactivated by key
Parking brake on		PARKING	BRAKE	P1;V8;D3 repetitive sound 10s max	+ig on* AND parking brake on AND V > 10 Km/h
Coolant level warning (DW10 engine only)		TOP_UP	WATER_LEVEL	P1;D3 single sound	+ig on* AND coolant level low
Low fuel		WARNING	LOW_FUEL	P2;V17	+ig on* AND low level reached
Front airbag fault				P1;V11;D3* single sound	+acc/+ig on* AND airbag fault
Side airbag fault				P1;V10;D3* single sound	+acc/+ig on* AND airbag fault
ABS fault		ABS_FAULT	NON_FUNCTION	P1;V5;D3 single sound	+ig on* AND ABS fault
Maintenance		ARRANGE	SERVICE	P2;V19	+acc AND key flashing
External temperature warning		RISK	OF_ICE	P2;D3 single sound	+acc AND -3°C < T < +3°C
Overspeed warning		PROG_SPEED	XXX_KM/H	P2;D2a single	V ≥ 130 Km/h (programmable)

* Engine running or not

MULTIPLEXED BSI - XSARA PICASSO AND XSARA – PART 4

IV - WARNINGS FROM THE VAN FRAMES

TYPE OF WARNING	SEQ	ASSOCIATED MESSAGE		LED PRIORITY; NOISE	APPEARANCE CONDITIONS
		ZONE" a"	ZONE" b"		
Coolant temperature warning	1 2	STOP ENGINE	TEMPERATURE	P1;V18;D3 (repetitive sound)	+acc/+ig on* AND $T \geq 118^{\circ}\text{C}$
Battery charging fault	1 2	BATTERY	FAULT	P1;V7;D3*	+acc/+ig on*/+cranking AND +EXC \leq +BAT-2.5V
Boot open		BOOT	OPEN	P1;D3*	Boot open AND +acc/+ig on*
Rear RH door open		RR RH DOOR	OPEN	P1;D3*	
Rear LH door open		RR LH DOOR	OPEN	P1;D3*	
Bonnet open		BONNET	OPEN	P1;D3*	
Front RH door open		FT RH DOOR	OPEN	P1;D3*	
Front LH door open		FT LH DOOR	OPEN	P1;D3*	
Engine immobiliser system fault	1 2	ENGINE IMMOBILISER	FAULT	P1	+ig on/+cranking AND system faulty
HF plip battery worn		CHANGE REMOTE	BATTERY CONTROL	P1	+acc/+ig on* AND battery low
Impact sensor	1 2	RE-ARM INERTIA	SENSOR	P0	+acc/+ig on AND impact detected
Headlamps left on reminder warning		HEADLAMPS	LEFT ON	P1;V12;D2b (repetitive sound emitted 10 min max)	Headlamps on AND Driver's door open (+acc/+ig on missing)
Key left in ignition reminder warning		KEY LEFT IN	IGNITION	P1;D2c repetitive	Key present (+acc/ +ig on missing 2s) AND Driver's door open
Overspeed warning active	1 2	WARNING SPEED	ACTIVE	P1	Overspeed activation in on-board ECU
Overspeed warning inactive	1 2	WARNING SPEED	INACTIVE	P1	Overspeed deactivation in on-board ECU
"Economy mode" active		ECONOMY MODE	ACTIVE	P1	The engine does not run for 30 mins

- engine running or not

MULTIPLEXED BSI - XSARA PICASSO AND XSARA – PART 4

MULTIPLEXED BSI - XSARA PICASSO AND XSARA – PART 4

INSTRUMENTATION FUNCTION

I - COOLANT TEMPERATURE GAUGE AND WARNING FUNCTION

A - GENERAL

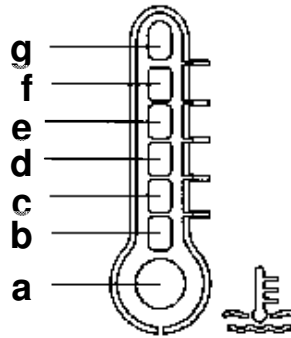

Table of correspondence between Coolant temperature / zone illuminated:

ZONE	a	b	c	d	e	f	g
TEMPERATURE °C	FIXED	$T \geq 60$	$T \geq 75$	$T \geq 100$	$T \geq 110$	$T \geq 115$	Warning

MULTIPLEXED BSI - XSARA PICASSO AND XSARA – PART 4

B - LAYOUTS

1 - EW7J4, DW10TD and TU5JPL4 engines

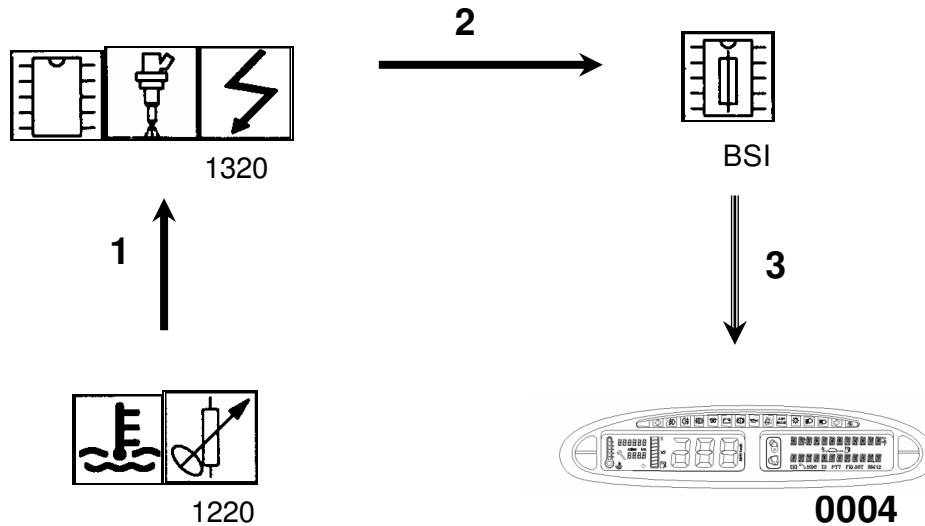

Key:

- Single arrow → wire connection
- Triple arrow → multiplexed connection

COMPONENTS	
BSI	Built-in systems interface
0004	Control panel (LEDs + microprocessor)
1220	Temperature sensor
1320	Engine management ECU



Signal type:

- 1 - Current depending on temperature.
- 2 - Square signal (PWM) for the temperature and All or nothing for the warning.
- 3 - VAN frame containing the temperature and possibly the warning information.

MULTIPLEXED BSI - XSARA PICASSO AND XSARA – PART 4

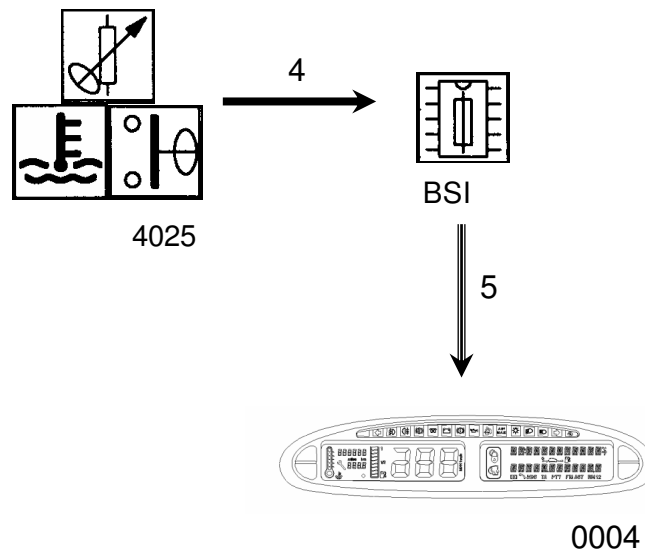
2 - TU5JPL3 engine without air conditioning



Key:  single arrow = wire connection
 triple arrow = multiplexed connection

COMPONENTS	
BSI	Built-in systems interface
0004	Control panel (LEDs + microprocessor)
4025	Temperature sensor + coolant thermosth

Signal type:

4 - Current depending on temperature.



All or nothing signal (possible warning).

5 - VAN frame containing the temperature and possibly the warning information.

MULTIPLEXED BSI - XSARA PICASSO AND XSARA – PART 4

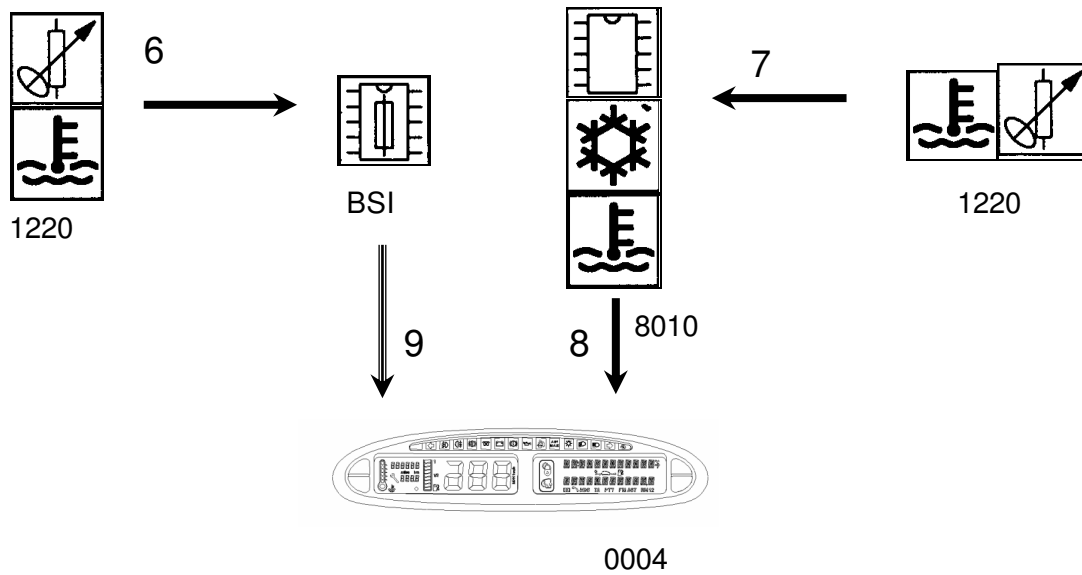
3 - TU5JPL3 engine with air conditioning



Key:  single arrow = wire connection
 triple arrow = multiplexed connection

COMPONENTS	
BSI	Built-in systems interface
0004	Control panel (LEDs + microprocessor)
1220	Temperature sensor
8010	Coolant temperature housing

Signal type:

- 6 - Current depending on temperature
- 7 - Current depending on temperature
- 8 - All or nothing signal (warning)
- 9 - VAN frame containing the temperature information

MULTIPLEXED BSI - XSARA PICASSO AND XSARA – PART 4

C - OPERATING MODES

1 - Operating phases

Nominal operation: see layouts and correspondence table.

- DW10TD, EW7J4 and TU5JPL4 engines:

The engine coolant temperature sensor (variable resistor) is connected to the engine management ECU. This converts the signal from the sensor into a variable frequency signal and sends it to the BSI. The engine management ECU also transmits the warning signal to the BSI.

The BSI encodes this information in a VAN frame to be sent to the control panel.

The coolant temperature gauge illuminates the corresponding temperature segments.

- TU5JPL3 engine

The temperature sensor supplies its current directly to the BSI. In AIR CONDITIONING mode, the temperature warning is given by an engine coolant temperature management unit.

2 - Specific operating cases

- Overheating warning

The BSI encodes a sound and a warning message in the VAN frame in addition to the temperature.

The 6 zones and the warning LED "g" are illuminated, a "warning beep" type sound is emitted repeatedly and the following message is displayed "STOP ENGINE TEMPERATURE".

- Downgraded mode

If the temperature sensor develops a fault, the BSI places a specific temperature code value in the VAN frame.

In the event of an invalid value, the control panel only illuminates zone "a".

II - FUEL LEVEL GAUGE FUNCTION

A - GENERAL

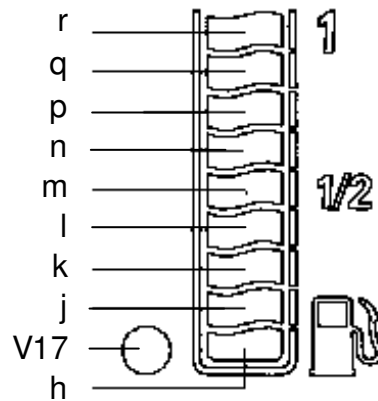

The following table gives the amount of fuel remaining as a function of the segment illuminated on the gauge:

⇒ petrol vehicle

ZONE	h	V17: WARNING	j	k	l
LITRES	$0 \leq V$	$V < 6$	$6 \leq V$	$12.5 \leq V$	$18.5 \leq V$
ZONE	m	n	p	q	r
LITRES	$24.5 \leq V$	$30.5 \leq V$	$36.5 \leq V$	$42.5 \leq V$	$49 \leq V$

⇒ diesel vehicle



ZONE	h	V17: WARNING	j	k	l
LITRES	$0 \leq V$	$V < 5$	$6.5 \leq V$	$13.5 \leq V$	$20 \leq V$
ZONE	m	n	p	q	r
LITRES	$26.5 \leq V$	$33.5 \leq V$	$40 \leq V$	$46.5 \leq V$	$53.5 \leq V$

MULTIPLEXED BSI - XSARA PICASSO AND XSARA – PART 4

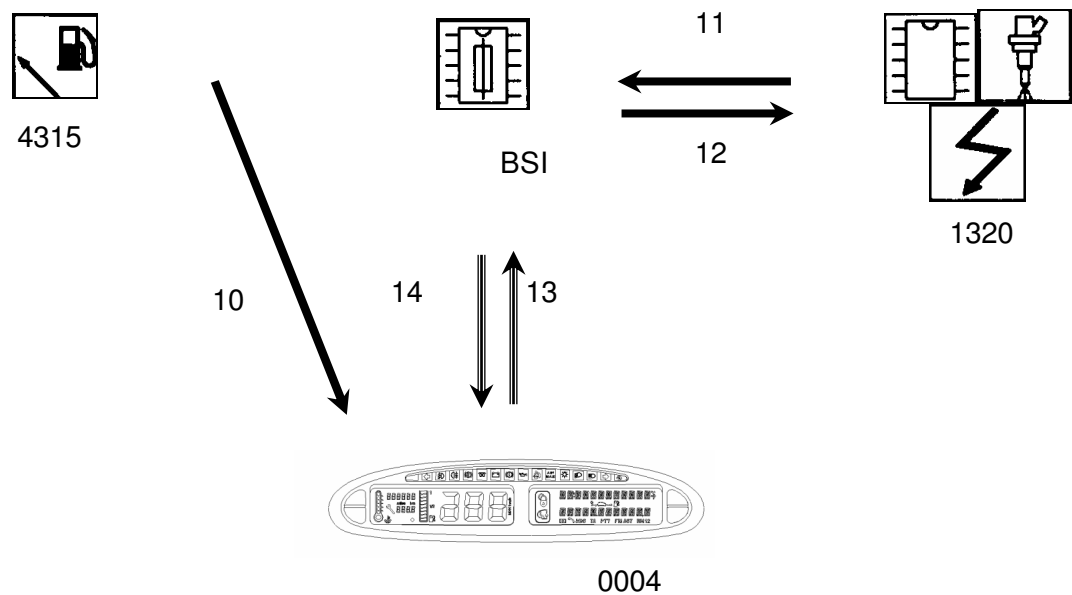
B - LAYOUT



Key:

 single arrow = wire connection
 triple arrow = multiplexed connection

COMPONENTS	
BSI	Built-in systems interface
0004	Control panel (LEDs + microprocessor)
1320	Engine management ECU
4315	Fuel sender

Signal type:

- 10 - Current depending on level of fuel in the tank
- 11 - Variable frequency signal depending on fuel flow
- 12 - Low fuel information signal
- 13 - VAN frame containing the gross fuel level given by the sender, the fuel level calculated by the control panel and the low fuel information
- 14 - VAN frames containing the vehicle consumption information

MULTIPLEXED BSI - XSARA PICASSO AND XSARA – PART 4

C - OPERATING MODES

1 - Operating phases

- When the ignition is switched on.

The control panel compares the last fuel level displayed with the level indicated by the fuel sender (variable resistor fitted with a float).

In the event of a significant difference, the gross level information is displayed otherwise the last fuel level displayed is given.

- When driving.

The fuel sender is no longer used.

The engine management ECU supplies the fuel flow information to the BSI.

The BSI calculates the vehicle's fuel consumption and encodes this information in a VAN frame.

The control panel takes this consumption information into account in order to calculate the fuel level. Finally, it transmits this level to the BSI via the VAN.

2 - Specific operating cases

- Low fuel warning

From a certain sender value, the control panel transmits the low fuel information to the BSI via the VAN in addition to the fuel level with the aim of warning the engine management ECU.

In addition, it displays the warning message "WARNING LOW FUEL". LED V17 is illuminated.

Note: The fuel capacity can be programmed depending on the vehicle engine (petrol or diesel).

III - SPEEDOMETER FUNCTION

A - GENERAL



The instantaneous speed of the vehicle is displayed on the digital displays of the instrumentation screen.

The driver can access the choice of measurement units (KM/H or MILES). The units are changed using the menu of the multifunction screen (refer to the Clock/Date/Temperature function). The units selected by the driver are stored and recalled the next time the ignition is switched on.

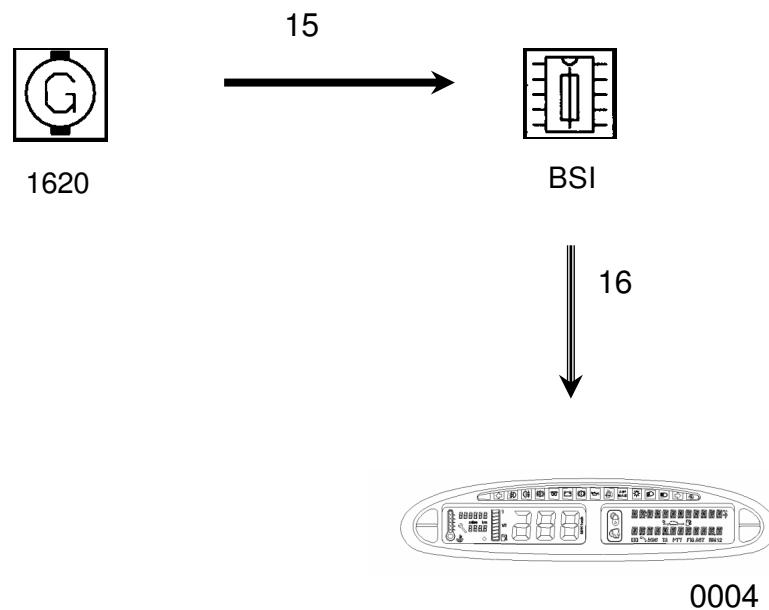
B - LAYOUT



Key:

 single arrow = wire connection
 triple arrow = multiplexed connection

COMPONENTS	
BSI	Built-in systems interface
0004	Control panel (LEDs + microprocessor)
1620	Vehicle speed sensor

Signal type:

15 - variable frequency signal proportional to the speed of the front wheels.

16 - VAN frame containing the instantaneous speed information.

MULTIPLEXED BSI - XSARA PICASSO AND XSARA – PART 4

C - OPERATING MODE

1 - Operating phase

Nominal operation: see layout

The speed sensor (located on the gearbox) supplies the BSI with a variable frequency signal.

The BSI calculates the instantaneous speed of the vehicle and encodes it in a VAN frame.

The control panel takes this information from the VAN network and displays it.

Specific operating cases

2 - Overspeed warning

The driver can access the choice of overspeed limit and does this using the menu of the multifunction screen on the control panel.

When the vehicle reaches this speed, the multifunction screen on the control panel displays the message: "PROG_SPEED XXX_KM/H". A two tone sound is emitted.

Note: this function is deactivated by default.

IV - MILEOMETER FUNCTION

A - GENERAL

Role: mileometer

The mileometer consists of two digital displays:

- the main mileometer,
- the tripometer.

B - LAYOUT

Refer to the speedometer layout.

C - OPERATING MODE

The BSI calculates the total distance travelled since the vehicle was first used from a signal supplied by the speed sensor. It then encodes the value in a VAN frame and sends it to the control panel.

The main mileometer displays the total distance travelled. The control panel calculates the distance travelled by the vehicle since the last time the tripometer was reset and displays this on the tripometer.

Note: The tripometer is reset when the ignition is on by pressing the button at the bottom left of the control panel (RESET).

D - SAVING THE DISTANCE TRAVELLED

The distance travelled is memorised in the control panel.

When the ignition is switched on, the BSI reads the distance memorised in the control panel and compares it with its own stored mileage. The BSI and the control panel store the largest of the two figures.

IMPORTANT: it is forbidden to perform diagnostics by substituting parts!

MULTIPLEXED BSI - XSARA PICASSO AND XSARA – PART 4

V - MAINTENANCE INDICATOR FUNCTION

A - GENERAL

1 - Role

The aim of the maintenance indicator is to improve the service to the customer by automatically showing when the next servicing operation is due.

Interval between maintenance operations.

Engine	Usage mode	frequency of maintenance operations*
Petrol	Normal	20000 Km or 12500 miles or 1 year
	Severe	15200 Km or 10000 miles or 1 year
Diesel HDI	Normal	20000 Km or 12500 miles or 1 year
	Severe	15200 Km or 10000 miles or 1 year

* The frequency of maintenance operations (in distance or time) can be programmed by the diagnostic tool.

2 - Display

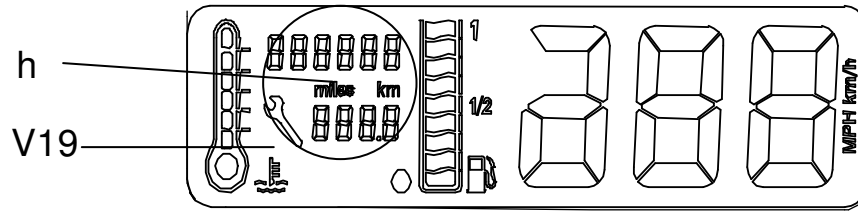

Zone "h": maintenance indicator.

Every time the engine is started, the distance remaining is displayed on the mileometer. LED V19 either illuminates or not.

	Service interval >2000 Km		Service interval <2000 Km		Service interval exceeded	
	0 - 2s	More	0 - 5s	More	0 - 5s	More
Display						
Mileometer and tripometer		X		X		X
Distance remaining or exceeded	X		X		X	
Key (LED V19)	X		X		X (flashing)	X
Message	X		X	X	X	X

Note: The message can be acknowledged by the driver or disappears itself 12 seconds after LED V19 starts flashing.

B - LAYOUT

Refer to the speedometer layout.

MULTIPLEXED BSI - XSARA PICASSO AND XSARA – PART 4

C - OPERATING MODES

1 - Nominal mode

The BSI calculates the total distance travelled from the signal supplied by the speed sensor. It then encodes the value in a VAN frame and sends it to the control panel.

The control panel calculates the distance remaining to be travelled before the next service using the following parameters:

- the maintenance frequency stored in the control panel (this is decremented as miles are driven),
- the time elapsed (incrementation of the number of days).

As soon as one of these parameters (time or remaining miles) becomes due, the multifunction screen indicates that the servicing date has been exceeded (LED V19 flashes, remains illuminated and the message remains displayed).

2 - Configuring the usage mode

The following procedure is used to select the Severe or Normal usage mode of the vehicle.

- 1 - Press the Tripometer reset button.
- 2 - Switch on the ignition.
- 3 - Release the button within 10 seconds.

The instrumentation screen displays a key (LED V19) and the current configuration of the vehicle, directly displaying the frequency of maintenance operations.

Pressing the reset button briefly switches between the configuration modes.

- 4 - Press for 10 seconds to validate.

The procedure exits automatically.

- 5 - Switch off the ignition.

3 - Initialising the maintenance indicator

The initialisation procedure is used to assign a new mileage value and a new time value to the system.

The procedure is as follows:

1 - Press the Tripometer reset button.

2 - Switch on the ignition.

The display shows a key (LED V19) and a 10 second counter starts to count down.

3 - Keep the Reset button pressed during these 10 seconds.

The key disappears and the reading "=0" appears. The operation is validated.

4 - Switch off the ignition to quit initialisation.

VI - CLOCK / DATE / TEMPERATURE FUNCTION

A - GENERAL

When these parameters are lost (i.e. after disconnecting the battery), the time displayed starts at "12: 00 PM" and the date displayed by default is 01 - 01 - 99. Each item (time and/or date) flashes until adjustment mode has been selected. By default, the language is French and the units are degrees Celsius and KM/H.

B - ADJUSTING SCREEN B

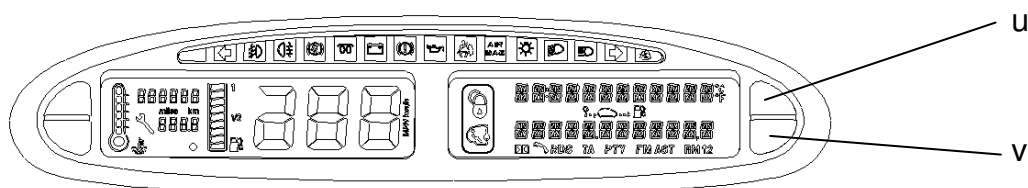

Buttons "u" and "v" located on the right hand side of the control panel are used to do this.

When the display is normal (no warnings, etc), pressing button "u" briefly changes the display to the date.

Pressing this button at any time for a long period returns to adjustment mode.

Every time this button is pressed again briefly, the parameter to be adjusted changes until adjustment mode is exited.

Conditions for exiting adjustment mode:

- Button not pressed for 6 seconds,
- Pressing button "u" for a long time.

MULTIPLEXED BSI - XSARA PICASSO AND XSARA – PART 4

Parameters (in the scrolling order):

Parameters	Description of the parameter to be displayed	Value of the parameter to be displayed
Languages	FRANCAIS; ENGLISH; DEUTSCH; ITALIANO; ESPANOL; etc.	
Hours (tens then units): 0 (or 12 AM depending on configuration)	HOUR	12 AM (or 12 for 24H configuration)
Minutes (tens then units): 00	MINUTES	01
Year (tens then units) 1998 (parameter: 98)	YEAR	2000
Month (tens then units): 01	MONTH	01
Day (tens then units): 01	DAY	01
Time format (12h / 24h)	12H/24H	12H (or 24H)
Temperature units (°C / °F)	°C/°F	°C (or °F)
Speedometer and mileometer units (KM/H - MPH)	KM/H-MPH	KM/H (or MPH)
Exit adjustment mode		

After the language has been selected, the HOUR, MINUTES, YEAR, MONTH and DAY parameters will be displayed in the configured language.

The possible languages are:

French, Spanish, Italian,
English, Portuguese, German,
Dutch.

Every time button "v" is pressed, the parameter to be adjusted is incremented.

Note: For the YEAR parameter, switching from 1900 to 2000 will occur automatically for all parameter values less than 99.

MULTIPLEXED BSI - XSARA PICASSO AND XSARA – PART 4

MULTIPLEXED BSI - XSARA PICASSO AND XSARA – PART 4

LIGHTING FUNCTION



I - RHEOSTAT FUNCTION

A - GENERAL

The + and - rheostat buttons are used to vary the brightness level of the lighting of the displays, except that of the warning LEDs.

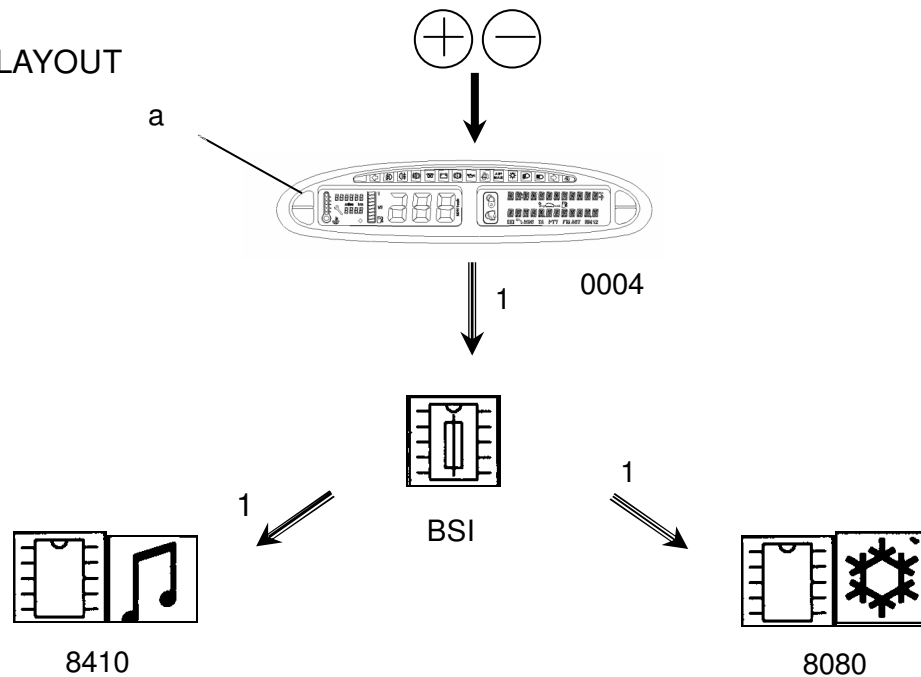
B - LAYOUT



Key:  single arrow = wire connection
 triple arrow = multiplexed connection

COMPONENTS	
BSI	Built-in systems interface
0004	Control panel (LEDs + microprocessor)
8080	Air conditioning compressor
8410	Radio
a	"Night driving" push button

Signal type:

1 - VAN frames containing the brightness status of the LEDs

MULTIPLEXED BSI - XSARA PICASSO AND XSARA – PART 4

C - OPERATING MODES

1 - Principle

The control panel encodes the brightness level in a VAN frame to be sent to the BSI.

The BSI transmits the information to the air conditioning and radio ECUs (RD2 only).

2 - downgraded mode

If one of the buttons is jammed, an intermediate brightness level is used by default.

II - NIGHT DRIVING FUNCTION

A - GENERAL

This function is used to extinguish all the LEDs on the control panel as well as the air conditioning display which generate light which may be tiring at night. Only the vehicle speed remains illuminated.

Warnings automatically cause the corresponding LED to illuminate.

B - LAYOUT

Refer to the rheostat function layout.

C - OPERATING MODES

- PRINCIPLE

The control panel encodes the status of the night driving function in a VAN frame to be sent to the BSI.

The BSI transmits the information to all the ECUs involved.

- ACTIVATION

This function is activated using button "a".

MULTIPLEXED BSI - XSARA PICASSO AND XSARA – PART 4

- DEACTIVATION

If an event occurs, this causes the zone in question to be re-illuminated in accordance with the table below:

EVENT	DISPLAY	DURATION
Brief press on one of the 4 buttons (user request)	All information on the control panel and multifunction screen	Until button "a" is pressed again
Engine overheating	Coolant temperature gauge	event duration
Fuel level < 15 litres	Fuel level gauge	Until the ignition is switched off or fuel added
Warning	Screen message without displaying the time, temperature, etc	Until the ignition is switched off or end of message timer (see message function)
Action on radio	Screen display	Timed for 6 seconds after last user action
Action on on-board ECU	Screen display	Timed for 6 seconds after last user action

MULTIPLEXED BSI - XSARA PICASSO AND XSARA – PART 4

ON-BOARD ECU FUNCTION

I - GENERAL

A - ROLE



The on-board ECU controls the display of the following information:

- Instantaneous consumption,
- Average consumption,
- Range,
- Average speed,
- Total distance travelled,
- Overspeed warning.

B - DISPLAY

Pressing the on-board ECU button briefly (located on the end of the stalk on the steering wheel) is used to switch to the next display.

The display is in digital form combined with a combination of icons on the multifunction screen to specify the type of information displayed.

ICONS	DESCRIPTION
	a vehicle coming from a round sign showing the last time the parameters were reset for the journey parameters (average speed, average consumption)
	a vehicle going towards a petrol pump for the range
	a vehicle on its own for the instantaneous consumption

MULTIPLEXED BSI - XSARA PICASSO AND XSARA – PART 4

II - LAYOUT

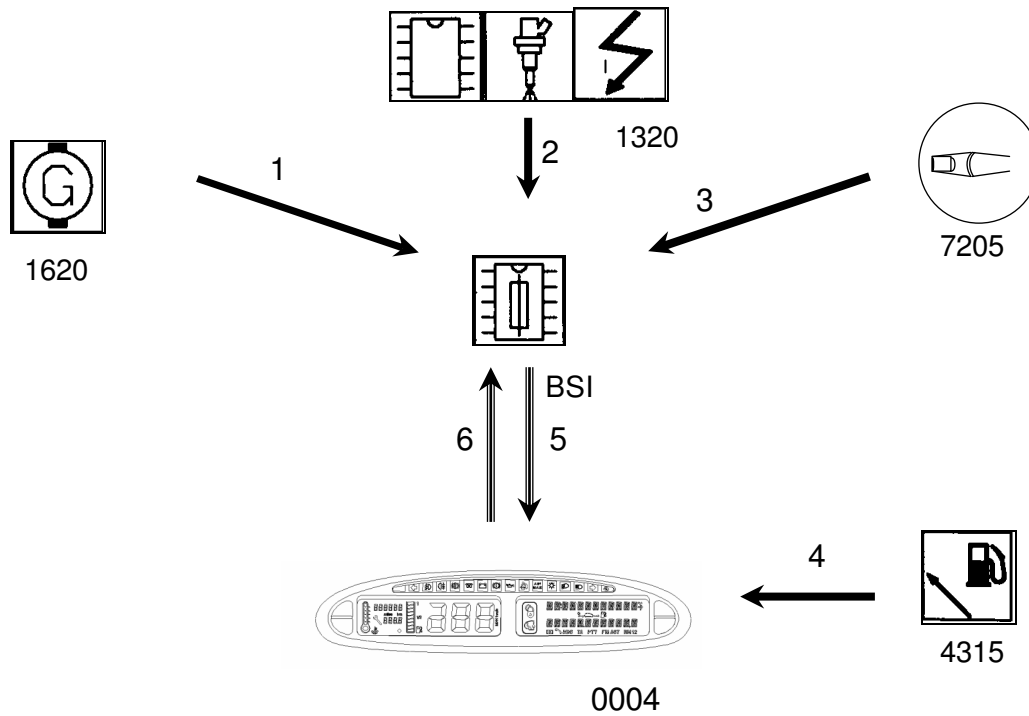

Key:

→ single arrow = wire connection
 ≡→ triple arrow = multiplexed connection

COMPONENTS	
BSI	Built-in systems interface
0004	Control panel (LEDs + microprocessor)
1320	Engine management ECU
1620	Speed sensor
4315	Fuel sender
7205	On-board ECU scroll switch

Signal type:

- 1 - variable frequency signal proportional to the speed of the front wheels
- 2 - variable frequency signal depending on fuel flow
- 3 - all or nothing signal
- 4 - current depending on gross fuel level
- 5 - VAN frames containing information from the on-board ECU for display
- 6 - VAN frame containing the fuel level.

MULTIPLEXED BSI - XSARA PICASSO AND XSARA – PART 4

III - OPERATING MODES

Nominal operation:

The BSI calculates the "range" with the fuel consumption and the amount of fuel remaining supplied by the control panel.

After acquiring the signal from the speed sensor, the BSI calculates the following parameters:

- "journey distance" since last reset,
- "average journey consumption" since last reset,
- "instantaneous consumption" with fuel flow information supplied by the engine management ECU,
- "average journey speed" since last reset,
- the BSI encodes this information in VAN frames to be sent to the control panel. The multifunction screen displays them.

Reset:

Pressing the on-board ECU switch for a long time on the steering wheel stalk resets the journey counters.

The BSI encodes this status on a VAN frame to be sent to the multifunction screen of the control panel.

MULTIPLEXED BSI - XSARA PICASSO AND XSARA – PART 4

ELECTRICITY

I - LAYOUT DIAGRAM

A - COOLANT TEMPERATURE WARNING AND GAUGE - TU5JP

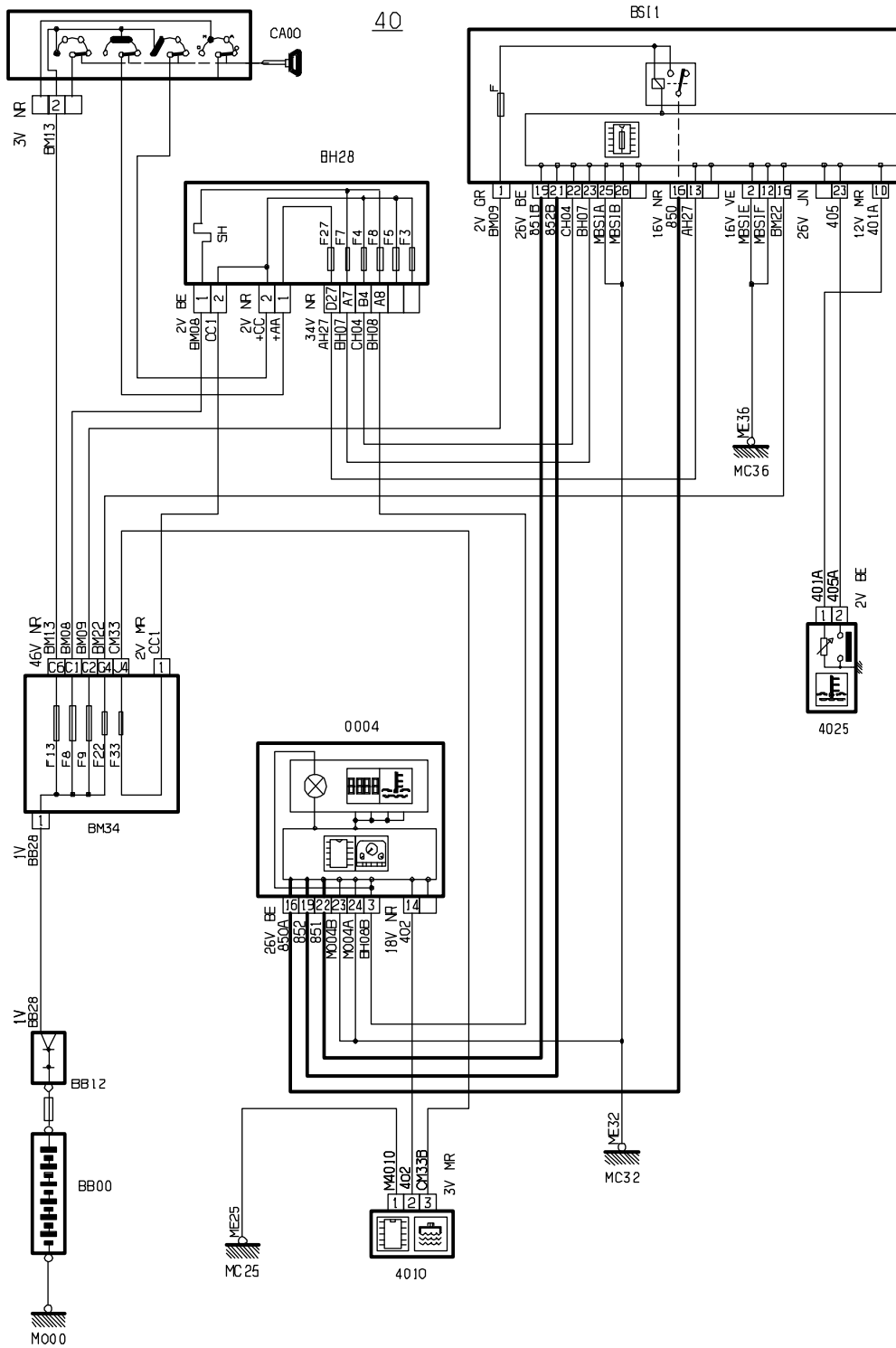

PFM004P

MULTIPLEXED BSI - XSARA PICASSO AND XSARA – PART 4

B - COOLANT TEMPERATURE WARNING AND GAUGE - DW10

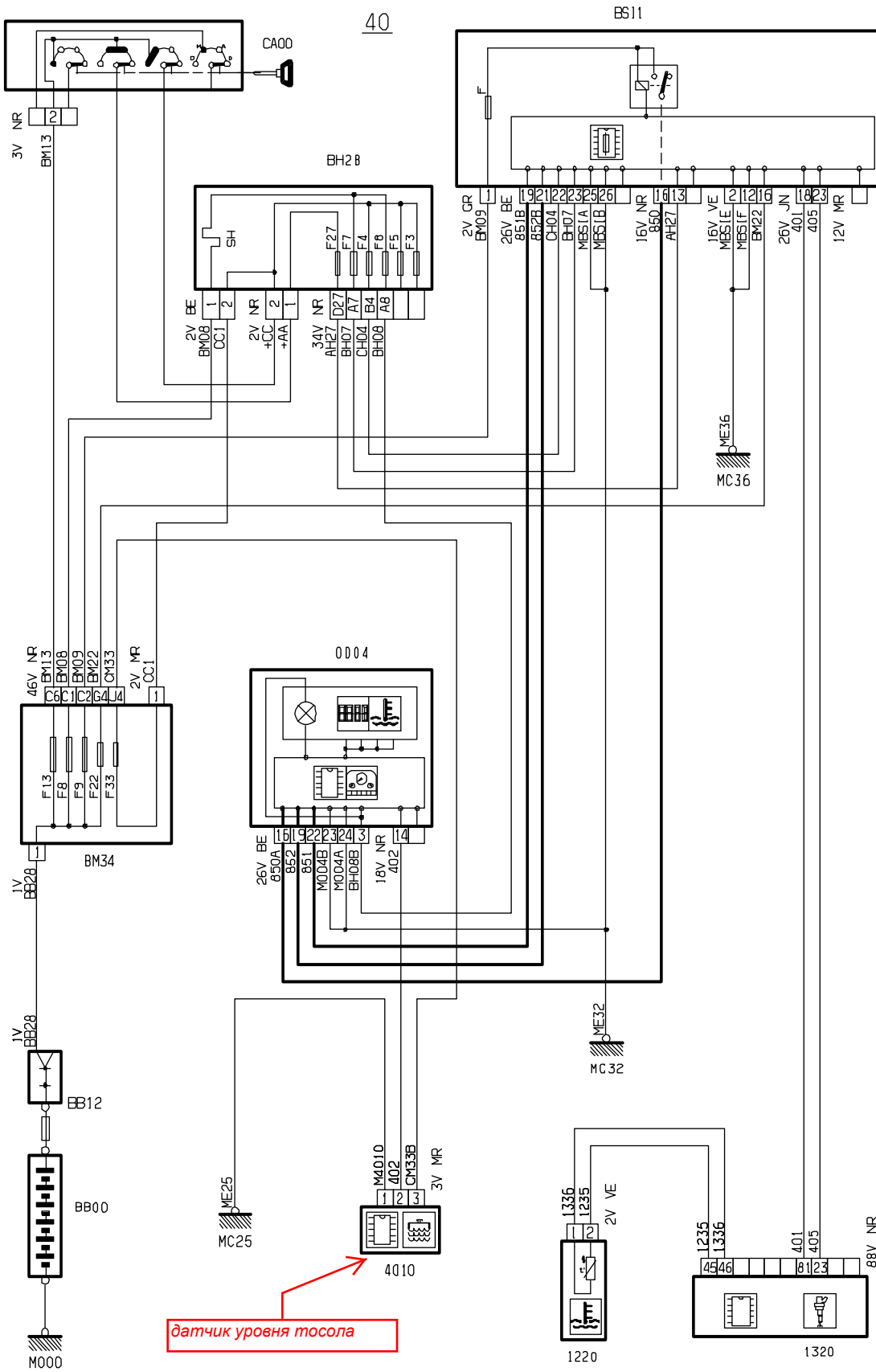

PFM005P

MULTIPLEXED BSI - XSARA PICASSO AND XSARA – PART 4

C - PETROL LEVEL GAUGE - EW7

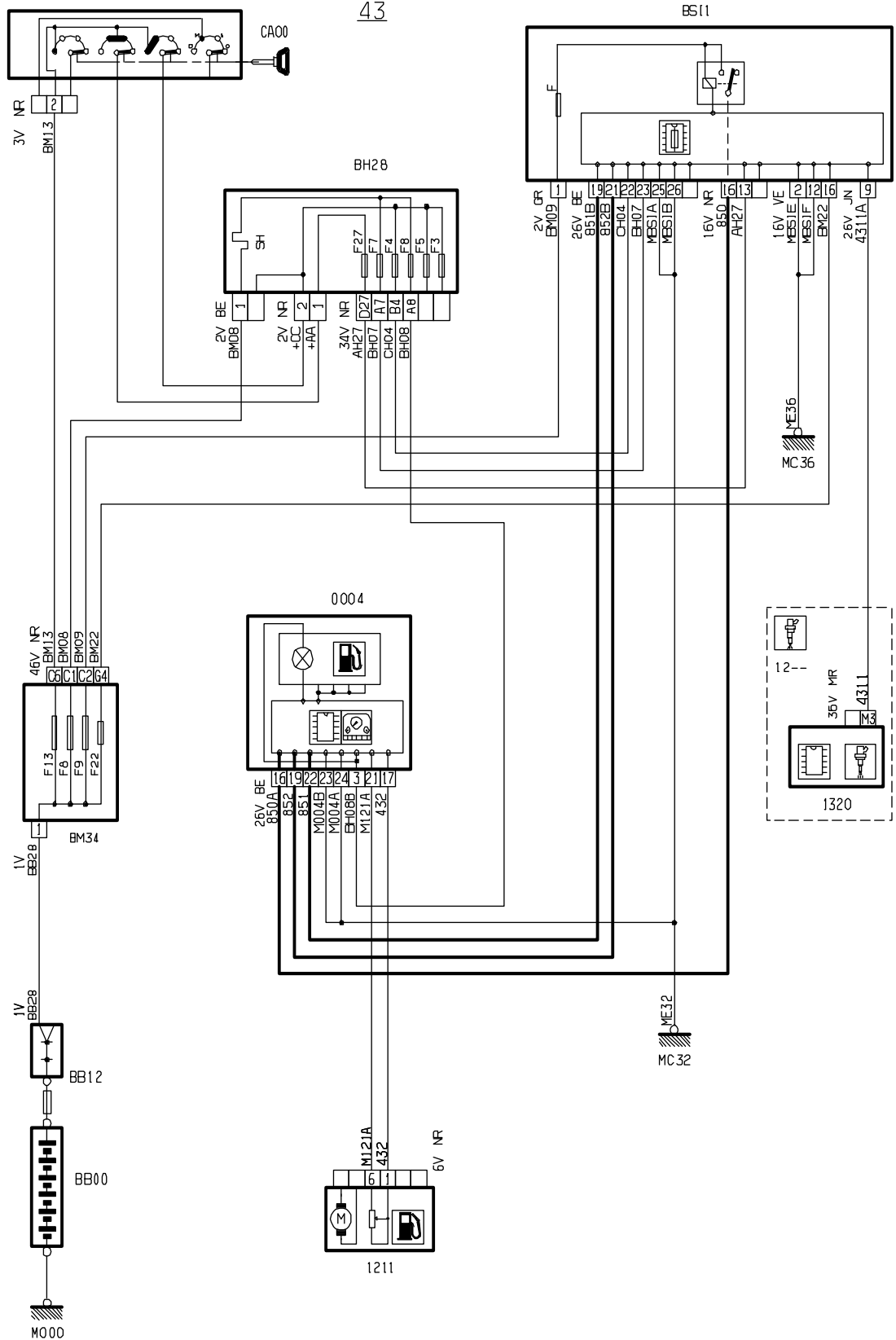

PFM006P

MULTIPLEXED BSI - XSARA PICASSO AND XSARA – PART 4

II - PARTS LIST

- BB00 - Battery
- BB12 - + battery connection terminal
- BH12 - 12 fuse box (passenger compartment)
- BH28 - 28 fuse box (passenger compartment)
- BM34 - 34 fuse engine relay unit
- BSI1 - Built-in systems interface
- C001 - Diagnostic connector
- CA00 - Ignition switch
- CT00 - Rotary connector
- 0002 - Signalling/lighting stalk
- 0004 - Control panel
- 0005 - Wiper stalk
- 1010 - Starter motor
- 1020 - Alternator
- 1203 - Inertia switch
- 1211 - Fuel sender pump
- 1220 - Engine coolant temperature sensor
- 1313 - Engine speed sensor
- 1320 - Engine management ECU
- 1620 - Vehicle speed sensor
- 2300 - Danger signal switch
- 2340 - Left hand side repeater
- 2345 - Right hand side repeater
- 2610 - Left hand headlamp
- 2615 - Right hand headlamp
- 2630 - Rear left hand lamp on body
- 2635 - Rear right hand lamp on body
- 3010 - Front interior lamp
- 3020 - Rear interior lamp
- 3050 - Lighting rheostat
- 3054 - Ashtray lighting
- 3105 - Boot (or tailgate) lighting

MULTIPLEXED BSI - XSARA PICASSO AND XSARA – PART 4

- 3110 - Glove box lighting switch
- 3115 - Glove box lighting
- 4010 - Engine coolant level switch
- 4025 - Temperature sensor - engine coolant thermostats (gauge)
- 5015 - Windscreen wiper motor
- 5115 - Windscreen/rear screen washer pump
- 6202 - Front door lock assembly driver's side
- 6207 - Front door lock assembly passenger's side
- 6260 - Boot locking motor
- 8006 - Evaporator thermistor (if separate)
- 8007 - Pressure switch
- 8008 - Air conditioning engine coolant temperature thermistor
- 8010 - Coolant temperature unit
- 8020 - Air conditioning compressor
- 8025 - Air conditioning control panel (if separate)
- 8030 - Passenger compartment air thermistor
- 8031 - Coolant thermistor
- 8045 - Blower control module (if separate)
- 8050 - Blower motor (if separate)
- 8065 - Mixing flap reduction motor
- 8070 - Air input flap reduction motor
- 8071 - Distribution flap reduction motor
- 8220 - Analogue module transponder
- 8410 - Radio
- 8413 - Radio control
- 8415 - Compact disc changer
- 8420 - Loud speakers on front door (driver's side)
- 8425 - Loud speakers on front door (passenger's side)
- 8430 - Loud speaker (rear left hand)
- 8435 - Loud speaker (rear right hand)
- 8440 - Front left hand tweeter speaker
- 8445 - Front right hand tweeter speaker
- 8500 - Navigation ECU

MULTIPLEXED BSI - XSARA PICASSO AND XSARA – PART 4

MULTIPLEXED BSI - XSARA PICASSO AND XSARA – PART 4

PART 5

DRIVER'S INFORMATION

XSARA

MULTIPLEXED BSI - XSARA PICASSO AND XSARA – PART 5

GENERAL

I - FOREWORD

The control panel is normal in appearance but several of its functions are multiplexed (mileometer, etc). Refer to the tables corresponding to the layout.

II - LAYOUT

The control panel receives information along the wires and by communicating with the ECUs via the VAN network.

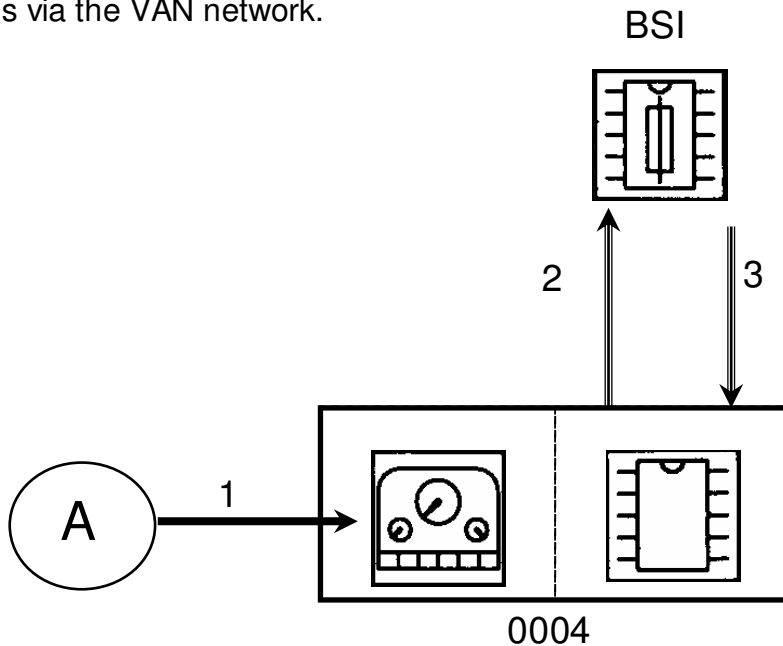

Key:

- single arrow = wire connection
- triple arrow = multiplexed connection

COMPONENTS	
BSI	Built-in systems interface
0004	Control panel (LEDs + microprocessor)
A	Pressure switch
	Oil level sensor
	Controls at the steering wheel
	Central airbag ECUs
	Side airbag ECUs
	Presence of water sensor
	Brake pad sensor
	Seatbelt contact
	Oil temperature sensor
	Oil level sensor
	Fuel sender
	Brake fluid sender
	Parking brake contact
	ABS valve block
	Automatic gearbox ECU

MULTIPLEXED BSI - XSARA PICASSO AND XSARA – PART 5

CONNECTIONS		
N°	Signal	Type
1	Low oil pressure	All or nothing
	Low coolant level	All or nothing
	Sidelamps status	All or nothing
	Dipped beam status	All or nothing
	Front airbag fault	All or nothing
	Side airbag fault	All or nothing
	Front and rear fog lamps control	All or nothing
	Water in diesel*	All or nothing
	Brake pad wear / Stop lamps	All or nothing (2 inputs)
	Presence of driver's seatbelt	All or nothing
	LPG level	analogue
	Brake fluid hydraulic level	All or nothing
	Oil level	Analogue
	Parking brake status	All or nothing
	ABS fault	LED active
	Electronic brakeforce distribution fault	All or nothing
	Auto gearbox selector position information	Square
2	Low fuel	VAN
	Filtered fuel level	VAN
	Gross fuel level	VAN
	ABS fault	VAN
	Auto gearbox fault	VAN
	Brake fluid fault	VAN
	Oil temperature	VAN
	Parking brake	VAN
	Dipped beam	VAN
	Saved journey distance	VAN
	Low oil pressure	VAN
	Electronic brakeforce distributor fault	VAN
	Control panel brightness level	VAN

MULTIPLEXED BSI - XSARA PICASSO AND XSARA – PART 5

CONNECTIONS		
N°	Signal	Type
3	Engine speed information	VAN
	Vehicle speed information	VAN
	Distance information	VAN
	Coolant temperature information	VAN
	Factory/customer mode	VAN
	Ignition key position	VAN
	Economy mode	VAN
	Engine running	VAN
	Coolant temperature warning	VAN
	Door open, engine running	VAN
	EOBD/Engine management fault	VAN
	Battery charge fault	VAN
	Electronic engine immobiliser system fault	VAN
	Illumination of indicator LEDs	VAN
	Lamps on reminder warning	VAN
	Key in ignition reminder warning	VAN
	Overspeed warning	VAN
	Day/night status	VAN
	Brightness level	VAN
	Set to stand-by in 5 seconds	VAN
	Activation of control panel	VAN
	Pre-heating information	VAN
	Auto gearbox safety warning	VAN
Total mileage	VAN	
Heated rear screen activated	VAN	

* depending on equipment

MULTIPLEXED BSI - XSARA PICASSO AND XSARA – PART 5

WARNING FUNCTION

I - LIST OF LEDS

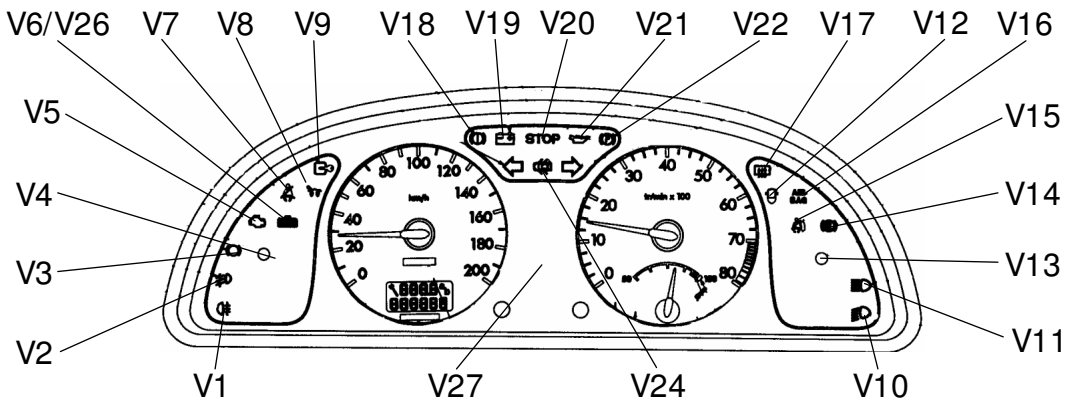

LED	FUNCTION
V1	Rear fog lamp
V2	Front fog lamp
V3	Brake pad wear indicator*
V4	Coolant temperature warning
V5	Engine management diagnostic
V6	Coolant level
V7	Seatbelt
V8	Diesel pre-heating
V9	Transponder fault
V10	Dipped beam
V11	Main beam
V12	Water in diesel
V13	Low fuel warning
V14	ABS
V15	Side airbag
V16	Front airbag
V17	Rear screen
V18	Brake fault
V19	Battery charge
V20	Stop
V21	Oil pressure
V22	Parking brake
V23	Left hand indicator
V24	Doors open
V25	Right hand indicator
V26	LPG operation
V27	Auto gearbox position display

* depending on equipment

Note 1: All possible LEDs are represented on the control panel above but this model of control panel does not actually exist.

Note 2: The LEDs cannot be replaced. If a bulb blows, replace the control panel.

MULTIPLEXED BSI - XSARA PICASSO AND XSARA – PART 5

II - INTEGRATED BUZZER

The buzzer integrated into the control panel produces 4 types of sound:

- "Relay clicking" type sound N1,
- "Intermittent" type sound N2,
- "Continuous" type sound N3,
- "Intermittent sound at twice the speed of N2" type sound N4.

III - WARNING APPEARANCE CONDITIONS

A - WARNINGS FROM WIRE INFORMATION

LED; NOISE	TYPE OF WARNING	APPEARANCE CONDITIONS
N3 only	Low oil level	+acc/+ig on
key	Maintenance key	+acc AND service imminent
V6	Coolant level warning	+ig on* AND coolant level low
V13	Low fuel	+ig on* AND low fuel reached
V15	Side airbag fault	+ig on* AND airbag fault
V16	Front airbag fault	+ig on* AND airbag fault
V16	Passenger's AIRBAG deactivated	+ig on* AND passenger's airbag deactivated
V14; N3 only	ABS fault	+ig on* AND ABS fault
V18; N3 only	Brake fluid / hydraulic level warning	+ig on* AND fluid level low
V18; N3 only	ABS fault	+ig on* AND ABS fault
V18; N3 only	Electronic brakeforce distributor fault	+ig on* AND braking system faulty
V20; N4	Low oil pressure warning	+ig on* AND oil pressure low
V21; N4	Low oil pressure warning	+ig on* AND oil pressure low
V22; N3	Parking brake	+ig on* AND parking brake on AND V > 10 Km/h

MULTIPLEXED BSI - XSARA PICASSO AND XSARA – PART 5

B - WARNINGS FROM VAN FRAMES

LED; NOISE	TYPE OF WARNING	APPEARANCE CONDITIONS
N2	Lamps on reminder warning	Headlamps on AND driver's door open (+acc/+ig on missing)
N2	Key in ignition reminder warning	Key present (+acc/+ig on missing) AND driver's door open
N2	Auto gearbox position warning	Key in position S or not inserted AND driver's door open AND lever in position other than P
N3	Overspeed warning	$V \geq 130$ Km/h (programmable in the BSI)
V4	Coolant temperature warning	+ig on* AND T° too high
V5	Engine management / EOB fault	+ig on AND engine ECU fault
V8	Diesel pre-heating	+ig on AND pre-heating in progress
V9; N3	Unknown transponder fault	+ig on/+cranking AND faulty system (unknown transponder)
V17	Heated rear screen	+ig on*/+cranking AND heated rear screen activated
V19; N3	Battery charging fault	+ig on* AND $+EXC \leq +BAT - 2.5V$
V20 flashing N4 active for 10s	Coolant temperature warning	+acc/+ig on* AND T° too high
V24; N3*	RRH door open	1 door open AND +acc/+ig on*
V24; N3*	RLH door open	
V24; N3*	FRH door open	
V24; N3*	FLH door open	
V27	Auto g/b position indicator	+ig on*/+cranking

* Engine running or not

MULTIPLEXED BSI - XSARA PICASSO AND XSARA – PART 5

MULTIPLEXED BSI - XSARA PICASSO AND XSARA – PART 5

INSTRUMENTATION FUNCTION

When the ignition is switched on, the digital display shows:

- for 2 seconds: the maintenance indicator
- for 5 seconds maximum: the oil level gauge
- and finally: the mileometer (until the ignition is switched off)

I - MAINTENANCE INDICATOR

A - GENERAL

1 - Interval between maintenance operations

Engine	Usage mode*	frequency of maintenance operations
Petrol/diesel HDI	Normal	20000 Km or 12500 miles or 1 year
	Severe	15000 Km or 10000 miles or 1 year
	Customised	Multiples of 500 Km or 1 month
Diesel (excl. HDI)	Normal	15000 Km or 10000 miles or 1 year
	Severe	10000 Km or 6000 miles or 1 year
	Customised	Multiples of 500 Km or 1 month

2 - Case of more than 2000 km to service

- The maintenance indicator shows the distance remaining for 2 seconds.
- The "key" symbol illuminates for 2 seconds then disappears.

3 - Case of less than 2000 km to service

- The maintenance indicator shows the distance remaining for 5 seconds.
- The "key" symbol illuminates for 5 seconds then disappears.

4 - Case of interval exceeded

- The maintenance indicator shows a zero distance remaining.
- The "key" symbol flashes for 5 seconds then disappears.

MULTIPLEXED BSI - XSARA PICASSO AND XSARA – PART 5

B - FUNCTIONAL DESCRIPTION

The BSI calculates the total distance driven from the signal supplied by the speed sensor. It then sends this to the control panel via the VAN network.

The control panel calculates the distance remaining to be travelled before the next service using:

- the maintenance frequency stored in the control panel (this is decremented as miles are driven),
- the time elapsed (incrementation of the number of days).

As soon as one of these parameters (time or remaining miles) becomes due, the multifunction screen indicates that the servicing date has been exceeded (the key flashes).

Note 1: When the time reaches one year, the maintenance indicator behaves as if the distance remaining were zero (the "key" symbol flashes).

Note 2: If the battery is disconnected, the time is no longer incremented.

C - INITIALISING THE MAINTENANCE INDICATOR

The procedure is as follows:

- 1 - Press the left hand button (Tripometer reset button).
- 2 - Switch on the ignition.

The display shows a key and a 10 second counter starts to count down to 0.

- 3 - Keep the button pressed until 0 is reached then release it.

The maintenance indicator displays the mileage to be travelled before the next service (it is equal to the maintenance frequency). The key disappears.

- 4 - Switch off the ignition to quit initialisation.

II - OIL LEVEL GAUGE

General

The amount of oil left in the engine is displayed in accordance with the graphics below for a maximum of 5 seconds:

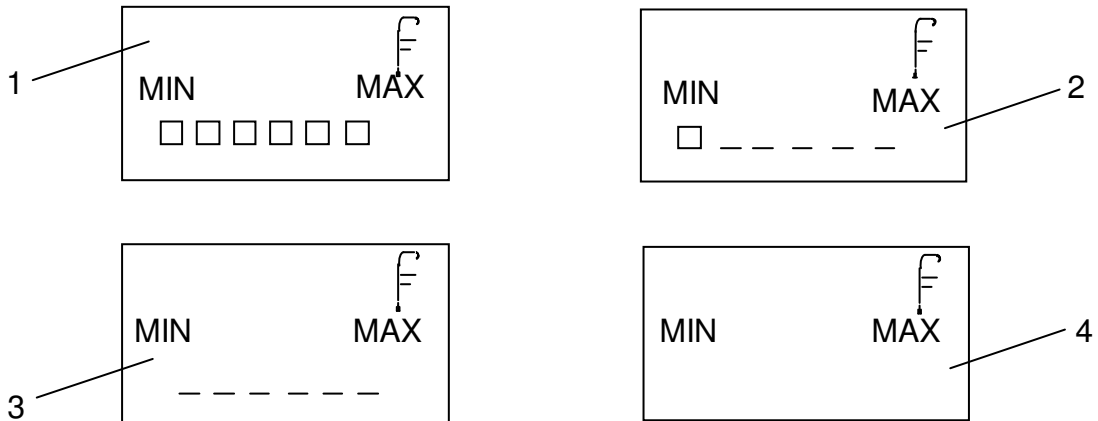

The number of squares illuminated is proportional to the potential difference at the terminals of the oil level sensor:

SCREEN	COMMENT	DISPLAY	CORRESPONDING POTENTIAL DIFFERENCE
1	Max level	6 squares illuminated	$\Delta U=90\text{mV}$
2	Min level	1 square illuminated	$\Delta U=440\text{mV}$
3	Level < min	No squares illuminated. 6 lines flash, warning beep N3, word MIN	$\Delta U>440\text{mV}$
4	Oil level sensor short circuited or disconnected	Screen flashes for 5 seconds	

Functional description

- The control panel sends a current of 195 mA (for approximately 2 seconds) into the oil level sensor.
- The control panel measures the potential difference (noted ΔU) at the sensor terminals.
- The control panel converts this potential difference into a number of squares to be displayed.

MULTIPLEXED BSI - XSARA PICASSO AND XSARA – PART 5

III - MILEOMETER

A - GENERAL

The control panel has two mileometer lines

- 2 tripometers called a and b (zone "b").
 - switch from a to b by briefly pressing the left hand button,
 - reset them by pressing and holding the left hand button.
- 1 main mileometer (zone "a").

Screen

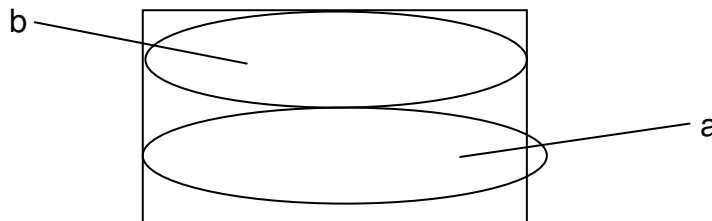

B - FUNCTIONAL DESCRIPTION

The BSI acquires the signal supplied by the speed sensor located on the gearbox. It then calculates the total number of miles and sends it to the control panel via the VAN network.

The control panel displays this mileage value on the main mileometer. From this value, it increments the tripometers a and b.

Note: On vehicles fitted with control panels in miles, the control panel converts the kilometres into miles.

C - SAVING THE DISTANCE TRAVELLED

The distance travelled is memorised in the control panel.

When the ignition is switched on, the BSI reads the distance memorised in the control panel and compares it with its own stored mileage. The BSI and the control panel store the largest of the two figures.

IMPORTANT: it is forbidden to perform diagnostics by substituting parts!
(storing of highest mileage)

MULTIPLEXED BSI - XSARA PICASSO AND XSARA – PART 5

REPAIRING THE CONTROL PANEL

I - READING AND ERASING FAULTS

Using the diagnostic tool, the following points can be read:

- identification of the PSA N° and the development index of the control panel,
- communications faults on the multiplexing,
- wire and multiplexed input faults on the control panel.

II - PROGRAMMING THE MAINTENANCE TYPE

Using the diagnostic tool, the following points can be programmed in the maintenance indicator:

- normal or severe configuration,
- customisation of the maintenance frequency as a distance (multiplies of 500 km),
- customisation of the maintenance frequency as a duration (multiples of 1 month),
- activation/deactivation of the maintenance indicator.

III - ACTUATOR TEST

Using the diagnostic tool, the following functions can be tested:

- mileometer (main mileometer and tripometer),
- speedometer,
- rev counter,
- fuel sender,
- coolant temperature gauge,
- oil temperature gauge,
- automatic gearbox position indicator,
- oil level,
- LEDs and symbols,
- the buzzer,
- change in lighting.

MULTIPLEXED BSI - XSARA PICASSO AND XSARA – PART 5

IV - READING THE FOLLOWING PARAMETERS

Control panel:

- viewing the activation status of certain LEDs (ABS, automatic gearbox, AIRBAG),
- viewing the maintenance type (missing/present, classic/developed, normal/severe).
- fuel sender and coolant temperature sender table.

All or nothing and other inputs on the control panel:

- oil min level/min pressure warning,
- oil temperature,
- side/front airbag LED,
- coolant level warning,
- driver's seatbelt,
- parking brake,
- Electronic Brakeforce Distributor fault/ABS fault,
- automatic gearbox fault,
- brake fluid level,
- fuel level,
- low fuel information,
- brightness level,
- dipped beam,
- change in status of all or nothing inputs

Control panel buttons:

- rheostat button,
- tripometer reset button.

MULTIPLEXED BSI - XSARA PICASSO AND XSARA – PART 5

PART 6

VISIBILITY

XSARA AND XSARA PICASSO

MULTIPLEXED BSI - XSARA PICASSO AND XSARA – PART 6

GENERAL

I - FOREWORD

The Built-in Systems Interface controls the visibility function:

FUNCTION	XSARA PICASSO	XSARA
Control of the windscreen wipers linked to the vehicle speed without rain sensor	X	
Windscreen wipers with rain sensor		*
Intermittent wipe mode of the rear wiper linked to vehicle speed and windscreen wiper mode	X	
Management of wiper parked positions	X	X
Protection of wiper motors	X	X
De-icing of heated rear screen	X	X
Timer for headlamp washers		*

* = Depending on equipment

MULTIPLEXED BSI - XSARA PICASSO AND XSARA – PART 6

II - GENERAL LAYOUT

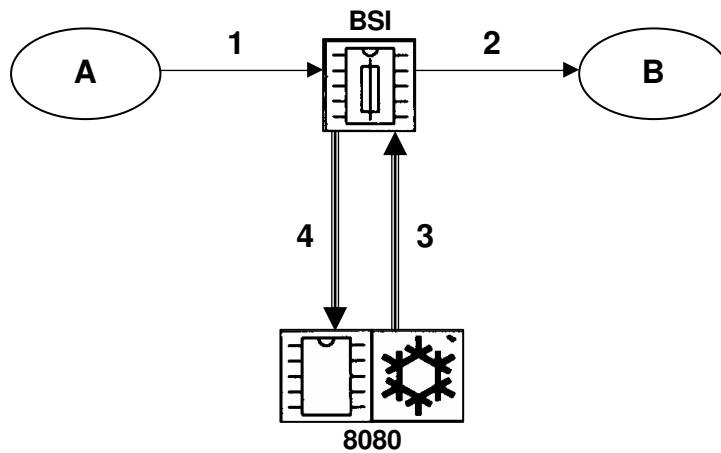

COMPONENTS	
BSI	Built-in Systems Interface.
8080	Automatic climate control (RFTA) on XSARA PICASSO only.
A	Heated rear screen switch (without RFTA)
	Windscreen wiper motor.
	Rear screen wiper.
	Steering wheel stalk
	Rain sensor (XSARA only)
B	Windscreen wiper motor
	Rear wiper motor
	De-icing LEDs of the heated rear screen and door mirrors (without RFTA climate control).
	Steering wheel stalk
	Windscreen and rear screen washer
	Headlamp washer (XSARA only)
	Heated rear screen and door mirrors.

MULTIPLEXED BSI - XSARA PICASSO AND XSARA – PART 6

CONNECTIONS		
n°	Signal	Type
1	Heated rear screen activation request (without RFTA)	All or nothing
	Parked position information of windscreen wiper motor	All or nothing
	Parked position information of rear wiper motor	All or nothing
	Windscreen washer request	All or nothing
	Rear screen washer request	All or nothing
	Windscreen wiper intermittent wipe request	All or nothing
	Windscreen wiper slow speed request	All or nothing
	Windscreen wiper high speed request	All or nothing
	Rear wiper request	All or nothing
	Supply (+ accessories)	Supply
	Rain detection information (XSARA only)	Analogue
2	Windscreen wiper motor high speed control	All or nothing
	Windscreen wiper motor slow speed control	All or nothing
	Rear wiper motor control	All or nothing
	De-icing and heated door mirrors LED control (except RFTA climate control).	All or nothing
	Accessories position output for steering wheel stalk, windscreen and rear screen washer	All or nothing
3	Heated rear screen activation request (RFTA only)	VAN
4	Heated rear screen functional status (RFTA only)	VAN

MULTIPLEXED BSI - XSARA PICASSO AND XSARA – PART 6

MULTIPLEXED BSI - XSARA PICASSO AND XSARA – PART 6

OPERATING PRINCIPLE

I - WINDSCREEN WIPER FUNCTION

A - BASIC FUNCTIONS

Function:

The wiper stalk for the windscreen wiper function provides the driver with the choice between several control options:

CONTROL	DESCRIPTION
Windscreen wash/wipe control	Used to wipe the screen continuously when the screen washer is activated.
Windscreen wiper one touch control	Used to activate the wipers at slow wipe speed. If the request is maintained, the wipers will wipe continuously at slow speed.
Intermittent / automatic wiper control	Without rain sensor: used to wipe the screen at regular intervals, at slow speed. A single wipe cycle is controlled between two parked positions. This timer is linked to the vehicle speed on the XSARA PICASSO
	With rain sensor: used to select automatic mode on the XSARA
Slow speed wiper control	The wiper control is activated continuously at slow speed
High speed wiper control	The wiper control is activated continuously at high speed

Note: Windscreen wiper requests are only taken into consideration by the BSI when the ignition is on.

MULTIPLEXED BSI - XSARA PICASSO AND XSARA – PART 6

B - CONTROLLING THE WINDSCREEN WIPERS LINKED TO VEHICLE SPEED WITHOUT RAIN SENSOR

This function contains 2 sub-functions which relate *only* to the XSARA PICASSO:

FUNCTION	OPERATION
Intermittent mode linked to vehicle speed	When the windscreen wipers are operating at intermittent speed, the vehicle speed information is used to adjust the parked time between 2 wipe cycles.
Reduction in wipe speed, vehicle stationary	This function consists of reducing the wipe speed when the vehicle is stationary. If operating at high speed, slow wipe speed is used. If operating at slow speed, intermittent wipe speed is used.

Wipe speed reduction occurs from 16 km/h when decelerating. The initial speed is returned to upon reaccelerating.

C - WINDSCREEN WIPER WITH RAIN SENSOR

The BSI controls the windscreen wipers depending on the requests from the rain sensor (in the base of the interior rear view mirror), on the Xsara only. The ignition must be on and the control initialised. Communications between the rain sensor and the BSI are by means of a serial link.

IMPORTANT: When washing the vehicle, ensure that the windscreen wipers or the ignition are off to prevent them being triggered by the rain sensor.

Note: If the rain sensor is covered, the windscreen wipers will perform an initialisation wipe cycle.

D - WINDSCREEN WASHER FUNCTION

The windscreen washer pump is not controlled by the BSI. The windscreen washer control comes directly from the washer pump. The BSI controls a delayed wipe cycle of the wipers (so as not to wipe when dry). When the driver stops pressing the washer control, the wipers perform a maximum of 3 complete wipe cycles before stopping.

Note: The washer control is only taken into consideration when the ignition is on.

MULTIPLEXED BSI - XSARA PICASSO AND XSARA – PART 6

II - REAR WIPER FUNCTION

On the Xsara and Xsara Picasso, the BSI controls a standard rear wiper (single motor).

A - BASIC FUNCTIONS

Function:

The rear wiper function has 3 operating modes:

OPERATING MODE	DESCRIPTION
Wash / wipe control	Used to wipe the screen continuously when the rear washer is activated.
Intermittent wipe control	Used to wipe the screen at regular intervals. This timer is linked to vehicle speed on the XSARA PICASSO.
Wiper control linked to reverse gear	Used to wipe the rear screen when reverse gear is engaged (XSARA PICASSO).

B - INTERMITTENT REAR WIPER MODE LINKED TO VEHICLE SPEED AND WINDSCREEN WIPER MODE

Function:

When the rear wiper control is requested, the BSI controls the rear wiper in intermittent mode. The parked time between 2 wipe cycles depends on the vehicle speed and the wiping speed of the windscreen wipers (XSARA PICASSO only).

C - REAR WASHER FUNCTION

Function:

The rear washer pump is not controlled by the BSI. The rear washer control controls the washer pump directly and leads to a rear screen wipe request to the BSI. When the driver stops operating the washer control, the wiper performs another 3 complete wipe cycles before stopping.

Note: The washer control is only taken into consideration when the ignition is on.

MULTIPLEXED BSI - XSARA PICASSO AND XSARA – PART 6

III - MANAGEMENT OF WIPER PARKED POSITIONS

Function:

CONDITION	FUNCTION
Ignition on	When the wipers are switched off, all wipe cycles in progress are completed. The wipers are systematically returned to the parked position at slow speed.
When the ignition is switched off	The windscreen or rear wipers stop immediately, regardless of the position of the wipers and the wiper stalk at the steering wheel.
When the ignition is switched on	If the wipers are not in the parked position, the BSI controls the wiper motors at slow speed until the wipers are in the parked position.

IV - WIPER PROTECTION

Function:

The BSI is used to protect the windscreen and rear wiper motors against overheating in the event of the wipers being blocked, regardless of the operating mode requested by the user. The controls are stopped if there has not been a change in the value of the parked position after a certain time.

V - DE-ICING

Function:

When the engine is running (and alternator charging), to de-ice the heated rear screen and the door mirrors, depending on vehicle equipment.

To protect the relay, when the voltage exceeds 15 volts, the de-icing request is no longer taken into account.

MULTIPLEXED BSI - XSARA PICASSO AND XSARA – PART 6

VI - HEADLAMP WASHER TIMER

This function exists on the **XSARA only**.

Function:

When the windscreen washer control is activated and if the dipped beam headlamps are on, the BSI controls the headlamp washer operating timer.

The dipped beam information is distributed on the Comfort VAN network by the control panel.

The headlamp washer pump is controlled by earthing a relay outside the BSI.

MULTIPLEXED BSI - XSARA PICASSO AND XSARA – PART 6

ELECTRICITY

I - LAYOUT DIAGRAM

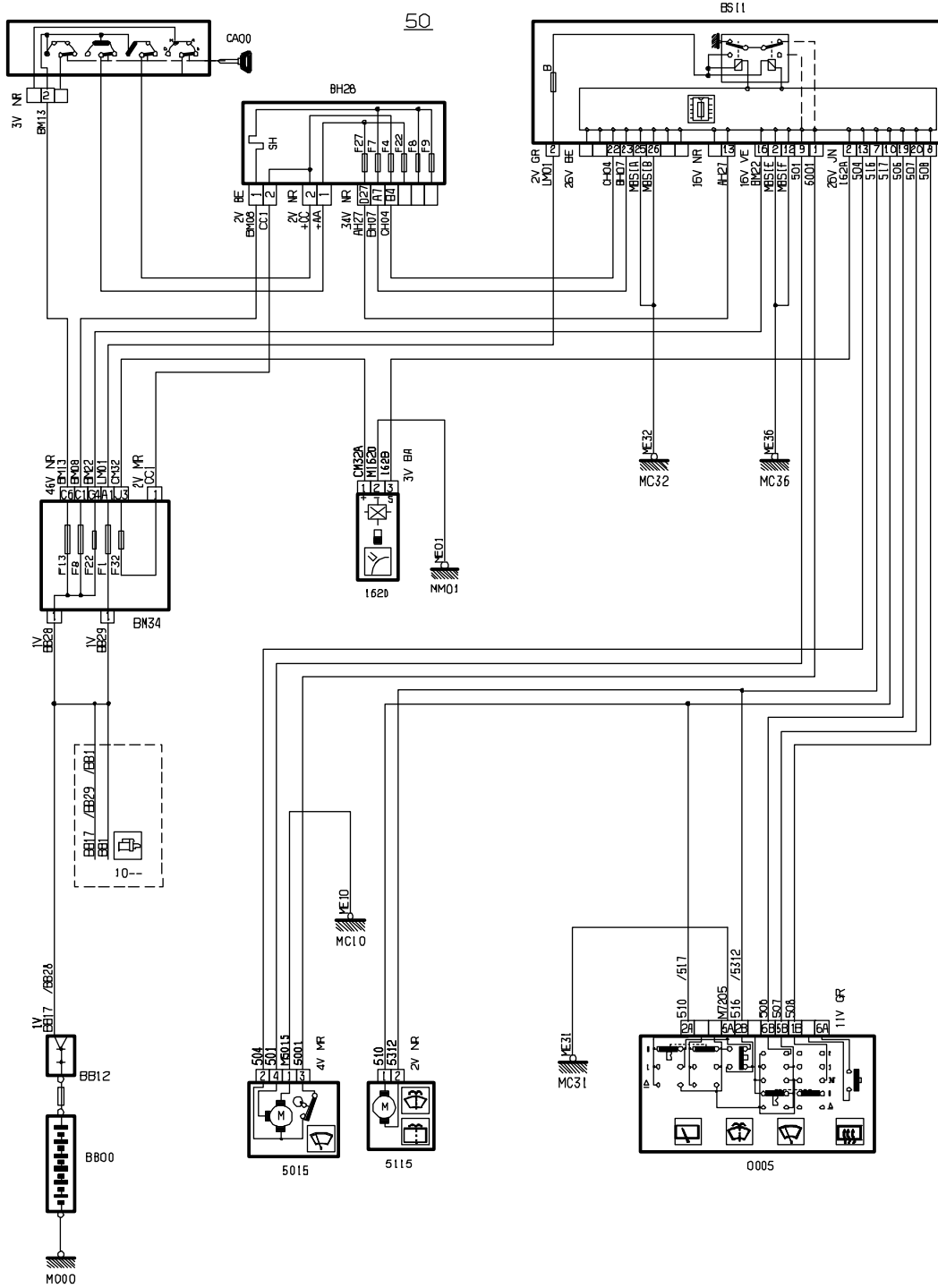

PFM007P

MULTIPLEXED BSI - XSARA PICASSO AND XSARA – PART 6

II - PARTS LIST

- BB00 - Battery
- BB12 - + battery connection terminal
- BH12 - 12 fuse box (passenger compartment)
- BH28 - 28 fuse box (passenger compartment)
- BM34 - 34 fuse engine relay unit
- BSI1 - Built-in systems interface
- C001 - Diagnostic connector
- CA00 - Ignition switch
- CT00 - Rotary connector
- 0002 - Signalling/lighting stalk
- 0004 - Control panel
- 0005 - Wiper stalk
- 1010 - Starter motor
- 1020 - Alternator
- 1203 - Inertia switch
- 1211 - Fuel sender pump
- 1220 - Engine coolant temperature sensor
- 1313 - Engine speed sensor
- 1320 - Engine management ECU
- 1620 - Vehicle speed sensor
- 2300 - Danger signal switch
- 2340 - Left hand side repeater
- 2345 - Right hand side repeater
- 2610 - Left hand headlamp
- 2615 - Right hand headlamp
- 2630 - Rear left hand lamp on body
- 2635 - Rear right hand lamp on body
- 3010 - Front interior lamp
- 3020 - Rear interior lamp
- 3050 - Lighting rheostat
- 3054 - Ashtray lighting
- 3105 - Boot (or tailgate) lighting

MULTIPLEXED BSI - XSARA PICASSO AND XSARA – PART 6

- 3110 - Glove box lighting switch
- 3115 - Glove box lighting
- 4010 - Engine coolant level switch
- 4025 - Temperature sensor - engine coolant thermostats (gauge)
- 5015 - Windscreen wiper motor
- 5115 - Windscreen/rear screen washer pump
- 6202 - Front door lock assembly driver's side
- 6207 - Front door lock assembly passenger's side
- 6260 - Boot locking motor
- 8006 - Evaporator thermistor (if separate)
- 8007 - Pressure switch
- 8008 - Air conditioning engine coolant temperature thermistor
- 8010 - Coolant temperature unit
- 8020 - Air conditioning compressor
- 8025 - Air conditioning control panel (if separate)
- 8030 - Passenger compartment air thermistor
- 8031 - Coolant thermistor
- 8045 - Blower control module (if separate)
- 8050 - Blower motor (if separate)
- 8065 - Mixing flap reduction motor
- 8070 - Air input flap reduction motor
- 8071 - Distribution flap reduction motor
- 8220 - Analogue module transponder
- 8410 - Radio
- 8413 - Radio control
- 8415 - Compact disc changer
- 8420 - Loud speakers on front door (driver's side)
- 8425 - Loud speakers on front door (passenger's side)
- 8430 - Loud speaker (rear left hand)
- 8435 - Loud speaker (rear right hand)
- 8440 - Front left hand tweeter speaker
- 8445 - Front right hand tweeter speaker
- 8500 - Navigation ECU

MULTIPLEXED BSI - XSARA PICASSO AND XSARA – PART 6

MULTIPLEXED BSI - XSARA PICASSO AND XSARA – PART 6

PART 7

LOCKING / UNLOCKING
XSARA AND XSARA PICASSO

MULTIPLEXED BSI - XSARA PICASSO AND XSARA – PART 7

GENERAL

I - FOREWORD

Control devices:

XSARA PICASSO	XSARA
BSI with integrated HF receiver	BSI with integrated HF receiver
Declutchable locks on both front doors	Declutchable locks on both front doors
One main key with transponder	One main key with transponder
One key with remote control and transponder	One key with remote control and transponder
Central locking button on dashboard	Door locking buttons
Electric boot opening button (external)	One garage key with transponder (does not open boot nor glovebox) on XSARA saloon
Unlocking by internal opening control on 4 doors	Unlocking by internal opening control on 2 front doors
Deactivation of internal opening of rear doors by rotary button on door panel (child safety)	Deactivation of internal opening of rear doors by rotary button on door panel (child safety)
Doors open detection contacts	Doors open detection contacts

MULTIPLEXED BSI - XSARA PICASSO AND XSARA – PART 7

Viewing device:

- "System status LED" for viewing the locked status, ignition off (in the hazard warning lamps button, on the XSARA PICASSO only),
- use of indicators,
- symbol for viewing the locking status, ignition on (XSARA PICASSO only),

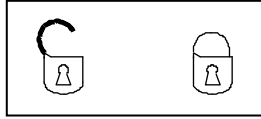

- symbol for viewing the child safety status on the XSARA PICASSO.

**Definitions:**

- a door is said to be closed if it is closed on the 2nd notch,
- the door open information is present when the + accessories is on,
- the fuel filler flap is locked with the key,
- a locking rebound consists of locking then unlocking the locks if a locking request was performed and if one of the doors is open (indicators do not illuminate),
- no locking buttons on the doors on the XSARA PICASSO.

The BSI controls the locking / unlocking function:

FUNCTION	XSARA PICASSO	XSARA
Locking / unlocking using internal button	X	
Opening of boot using electric button	X	
Unlocking in the event of an impact	X	
Deadlocking using the key		X
Deadlocking using the plip		X
Rebound function	X	X
Automatic locking	X	
Locking / unlocking using the key	X	X
Locking / unlocking using the plip	X	X
Protection of lock motors	X	X

MULTIPLEXED BSI - XSARA PICASSO AND XSARA – PART 7

II - GENERAL LAYOUT

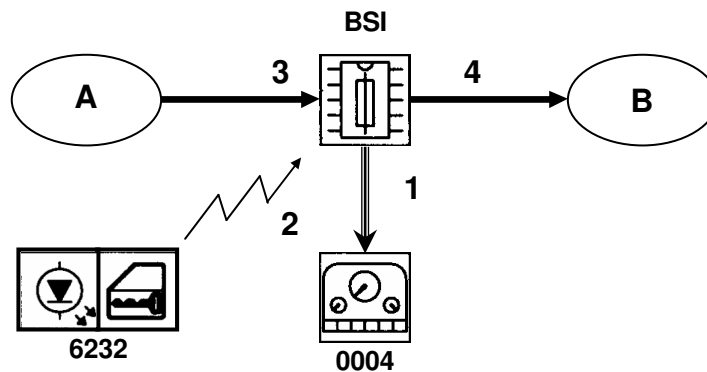

COMPONENTS	
BSI	Built-in Systems Interface with integrated HF receiver
0004	Control panel
6232	High frequency emitter for locking doors.
A	Boot opening button
	Central locking button
	Switches of the 4 doors (door status)
	Boot switch
	Inertia switch (Xsara Picasso)
	Contacts of 2 front locks (key)
	Interior opening control of front doors (+ locking buttons on the doors on the XSARA).
B	Locking actuators.
	Unlocking actuators.
	Deadlocking actuators
	Boot opening actuators
	Indicators (front, rear, left hand, right hand, side repeaters)
	System status LED.

MULTIPLEXED BSI - XSARA PICASSO AND XSARA – PART 7

CONNECTIONS		
n°	Signal	Type
1	Vehicle locking status information (for symbol on the instrument panel)	VAN
	HF plip batteries worn warning	VAN
	Door open, engine running warning	VAN
	Door status information	VAN
	Control of indicators	VAN
2	Locking / unlocking / deadlocking request by plip	Encrypted HF
3	Boot opening request	All or nothing
	Locking / unlocking request by button	All or nothing
	Door status information	All or nothing
	Boot opening status information	All or nothing
	Impact detection input (Xsara Picasso)	All or nothing
	Locking / unlocking request by key	All or nothing
4	Locking actuators control	All or nothing
	Unlocking actuators control	All or nothing
	Deadlocking actuators control	All or nothing
	Boot opening actuator control	All or nothing
	Indicators control (front, rear, left hand, right hand, side repeaters)	All or nothing
	System status LED control	All or nothing

MULTIPLEXED BSI - XSARA PICASSO AND XSARA – PART 7

MULTIPLEXED BSI - XSARA PICASSO AND XSARA – PART 7

OPERATING PRINCIPLE

I - LOCKING / UNLOCKING

A - LOCKING / UNLOCKING USING THE KEY

Function:

This function consists of locking or unlocking the vehicle using the key by operating the locks of the front doors.

Functional description:

FUNCTION	LOCKING	UNLOCKING
Action	the BSI controls locking	the BSI controls unlocking
IF condition	locking order through the front locks	unlocking order through the front locks
AND condition	the vehicle is unlocked	the vehicle is locked
AND condition	the ignition has been off for more than 3 seconds	
AND condition	the doors are closed (otherwise, rebound occurs)	
Display	Illumination of indicators and side repeaters for 2 seconds. Illumination of system status LED	Flashing of indicators and side repeaters for 2 seconds. Extinguishing of system status LED

MULTIPLEXED BSI - XSARA PICASSO AND XSARA – PART 7

B - LOCKING / UNLOCKING USING THE PLIP

Function:

This function consists of locking or unlocking the vehicle, when the ignition is off, following an order from the HF remote control (plip).

Functional description:

FUNCTION	LOCKING	UNLOCKING
Action	the BSI controls locking	the BSI controls unlocking
IF condition	locking order from the plip	unlocking order from the plip
AND condition	the vehicle is unlocked	the vehicle is locked
AND condition	the ignition has been off for more than 3 seconds	
AND condition	the doors are closed (otherwise, rebound occurs)	
Display	<p>Illumination of indicators and side repeaters for 2 seconds.</p> <p>Illumination of system status LED.</p>	<p>Flashing of indicators and side repeaters for 2 seconds.</p> <p>Extinguishing of system status LED.</p>

Note: Two locking / unlocking orders from the HF remote control will only be performed if there is a minimum of 0.6 seconds between them.

MULTIPLEXED BSI - XSARA PICASSO AND XSARA – PART 7

C - LOCKING / UNLOCKING USING THE INTERIOR BUTTON

Function:

This function consists of locking the vehicle following a request from the user by pressing the locking button located on the dashboard. All the doors and tailgate/boot will be alternately locked or unlocked every time the button is pressed.

Functional description:

FUNCTION	LOCKING	UNLOCKING
Action	the BSI controls locking	the BSI controls unlocking
IF condition	locking order from the button	unlocking order from the button
AND condition	the vehicle is unlocked	the vehicle is locked
AND condition	the doors are closed (otherwise, rebound occurs)	
Display	Illumination of system status LED or symbol on control panel (depending on key position)	Extinguishing of system status LED

Display:

- permanent correspondence between the locking status of the doors and the symbol on the control panel (if the ignition is on).
- flashing of the system status LED (ignition off) .

MULTIPLEXED BSI - XSARA PICASSO AND XSARA – PART 7

D - OPENING THE BOOT USING THE ELECTRIC BUTTON

Function:

This function consists of controlling the boot lock actuator by pressing the electric boot opening control button (located on the boot).

Functional description:

FUNCTION	UNLOCKING THE BOOT USING THE BUTTON
Action	the BSI controls unlocking of the tailgate, then illuminates the boot lamp
IF condition	unlocking order from the boot button
AND condition	the vehicle is unlocked
AND condition	the speed has not exceeded 5 km/h since the last time a door was opened
AND condition	the boot is closed

The lock is fitted with a device for opening the boot from the inside, should an operating fault occur. To do this, insert a rod into the hole at the bottom left of the lock from inside the boot.

E - REBOUND FUNCTION

Function:

A rebound upon locking consists of locking then unlocking the locks if a locking request is made and if one of the doors is open (no illumination of indicators).

Functional description:

FUNCTION	REBOUND
Action	the BSI controls locking, then unlocking of the doors
IF condition	a locking request is made (from any source)
AND condition	the vehicle is unlocked
AND condition	one of the doors is not closed to the 2 nd notch
Display	no illumination of indicators (since locking does not occur)

MULTIPLEXED BSI - XSARA PICASSO AND XSARA – PART 7

F - AUTOMATIC RE-LOCKING

Function:

This function consists of preventing the vehicle from being left unlocked due to negligence.

Functional description:

FUNCTION	RE-LOCKING
Action	the BSI automatically relocks the vehicle
IF condition	no door has been opened within 30 seconds of unlocking the vehicle.

G - UNLOCKING IN THE EVENT OF AN IMPACT

Function:

This function consists of unlocking the vehicle in the event of an impact. It is prohibited after locking using the plip or the key.

Functional description:

The impact is detected by an inertia switch mounted on a rigid part of the vehicle structure (mechanical switch).

FUNCTION	UNLOCKING IN THE EVENT OF AN IMPACT
Action	the BSI controls unlocking of the doors if an impact is detected
IF condition	the impact detection input is activated
AND condition	the vehicle is locked
AND condition	the ignition is on
Display	change in status of the symbol on the control panel

Note: This function is not totally reliable. It depends on the size and type of the impact. The fact that unlocking has occurred in the event of an impact must therefore not be communicated within the system.

MULTIPLEXED BSI - XSARA PICASSO AND XSARA – PART 7

H - PROTECTION OF LOCK MOTORS

Function:

To prevent overheating, the BSI protects the lock actuators (doors and boot).

Functional description:

The vehicle is unlocked during the motor protection function.

FUNCTION	PROTECTION OF LOCK MOTORS
Action	The lock actuators are prevented from operating for 30 seconds
IF condition	10 successive locking/unlocking operations have been performed in less than 2 minutes

II - DEADLOCKING

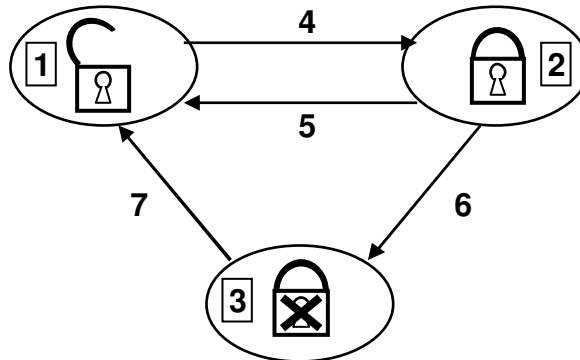

KEY			
1	Unlocked status	4	Locking
2	Locked status	5	Unlocking
3	Deadlocked status	6	Deadlocking
		7	Unlocking

Note: It is not possible to switch from the deadlocked status to the locked status.

A - DEADLOCKING USING THE KEY

Function:

This function consists of deadlocking the vehicle, using the key, after locking it by operating the front door locks when the ignition is off.

Functional description:

FUNCTION	DEADLOCKING USING THE KEY
action	the BSI deadlocks the vehicle
IF condition	the door lock contact is operated for at least 0.7 seconds (definable)
AND condition	the vehicle has been locked for less than 5 seconds (definable)
AND condition	all the doors are closed
AND condition	the ignition is off
Display	illumination of indicators for 2 seconds (extinguished for 0.5 s beforehand if they were illuminated)

MULTIPLEXED BSI - XSARA PICASSO AND XSARA – PART 7

B - DEADLOCKING USING THE PLIP

Function:

This function consists of deadlocking the vehicle after locking it, when the ignition is off, following an order from the HF remote control.

Functional description:

FUNCTION	DEADLOCKING USING THE PLIP
Action	the BSI deadlocks the vehicle
IF condition	the locking button on the HF remote control is pressed
AND condition	the vehicle has been locked for less than 5 seconds (definable)
AND condition	all the doors are closed
AND condition	the ignition is off
Display	illumination of indicators for 2 seconds (extinguished for 0.5 seconds beforehand if they were illuminated)

PART 8

AUTOMATIC CLIMATE CONTROL

XSARA PICASSO

MULTIPLEXED BSI - XSARA PICASSO AND XSARA – PART 8

GENERAL

I - FOREWORD

The automatic climate control system allows the user to control the operation of the air conditioning-heating system automatically, by adjusting:

- the air flow (blower motor),
- the air temperature (mixing),
- the distribution of air in the passenger compartment (distribution),
- the air inlet (recycling),
- the air conditioning function.

The desired temperature is obtained by setting the mixing flap, controlled by a stepper motor, to the correct position.

The heating is provided by a heater matrix in the engine coolant circuit.

The cold air is produced by a traditional cooling system through an evaporator.

The air flow is provided by a blower motor.

The distribution and air inlet are adjusted by flaps controlled by stepper motors.

The control panel also includes the control for the heated rear screen (this is totally independent to the other air conditioning functions).

There are two types of air conditioning management, depending on the engine:

	1.6i (TU5JP engine)	1.8i (EW7J4 engine)	2.0 TD (DW10TD engine)
Type C	X		
Type D		X	X



Type C: the engine management ECU does not control the engine cooling. The engine ECU is called "non FRIC". The coolant temperature warning signal is sent to the BSI by the air conditioning management unit.

Type D: the engine management ECU controls the engine cooling. The engine ECU is called "FRIC". The coolant temperature warning signal is sent to the BSI by the engine management ECU.

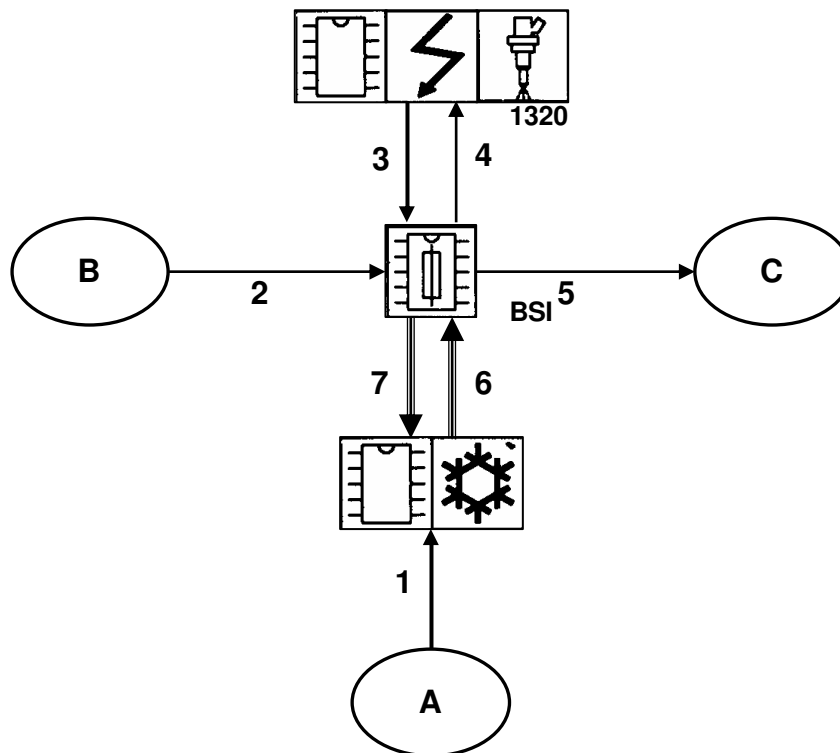
II - GENERAL LAYOUT



Key:

-  single arrow = wire connection
-  triple arrow = multiplexed connection

MULTIPLEXED BSI - XSARA PICASSO AND XSARA – PART 8

COMPONENTS	
BSI	Built-in Systems Interface
1320	Engine management ECU
8080	Automatic climate control (RFTA)
A	Heater matrix coolant temperature sensor
	Passenger compartment temperature sensor
B	Refrigerant pressure sensor
	Evaporator temperature sensor
	Alternator
	External air temperature sensor
	Engine coolant temperature sensor
	Vehicle speed sensor
	Heated rear screen
	Heated door mirrors
	Air conditioning compressor
C	Heated rear screen relay
	Heated door mirrors
	Air conditioning compressor

MULTIPLEXED BSI - XSARA PICASSO AND XSARA – PART 8

CONNECTIONS		
n°	Signal	Type
1	Heater matrix coolant temperature	Analogue
	Passenger compartment temperature	Analogue
	User instructions (temperature, operating mode)	All or nothing
2	Refrigerant pressure	Analogue
	Evaporator temperature	Analogue
	Alternator output voltage (engine running information)	Analogue
	External air temperature	Analogue
	Coolant temperature (for non FRIC engine ECU)	Analogue
	Vehicle speed	Frequency
3	Compressor authorisation	All or nothing
	Coolant temperature (for FRIC engine ECU)	Frequency
4	Air conditioning compressor engaging request	All or nothing
5	Heated rear screen relay control	All or nothing
	Heated door mirrors control	All or nothing
	Compressor control	All or nothing
6	Compressor activation request	VAN
	Recycling information	VAN
	Heated rear screen activation request (for engine running)	VAN
7	Compressor status	VAN
	Air conditioning activation	VAN
	Compressor authorisation	VAN
	Coolant temperature/pressure safety, evaporator	VAN
	Heated rear screen operating status	VAN
	Engine running information	VAN
	External air temperature	VAN
	Evaporator temperature	VAN
	Brightness level	VAN
	Day / night status	VAN
	Black Panel status	VAN
	Economy mode	VAN
	Set to stand-by within 5 seconds	VAN
Position of ignition key	VAN	

MULTIPLEXED BSI - XSARA PICASSO AND XSARA – PART 8

III - LAYOUT DIAGRAM

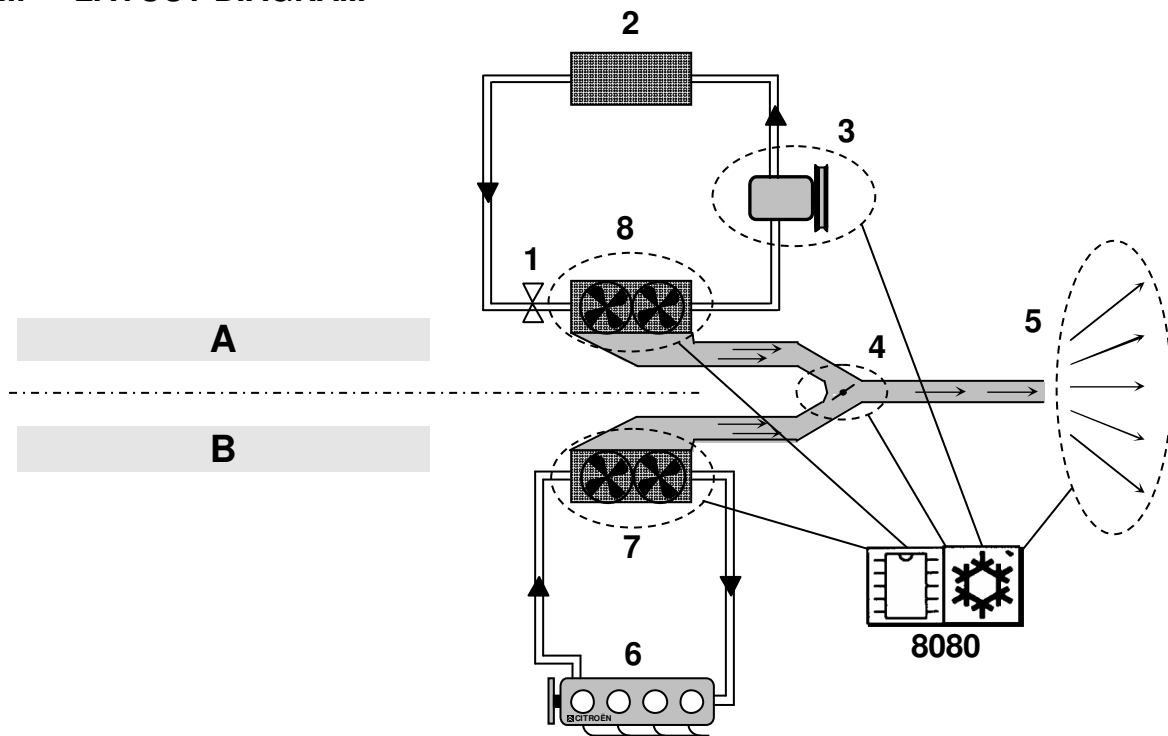

KEY			
A	Cold air circuit	4	Temperature adjustment
B	Warm air circuit	5	Air distribution in passenger comp.
8080	Air conditioning	6	Engine
1	Pressure relief valve	7	Heater matrix
2	Capacitor	8	Evaporator
3	Compressor		

MULTIPLEXED BSI - XSARA PICASSO AND XSARA – PART 8

IV - DESCRIPTION OF THE USER DISPLAY AND CONTROLS

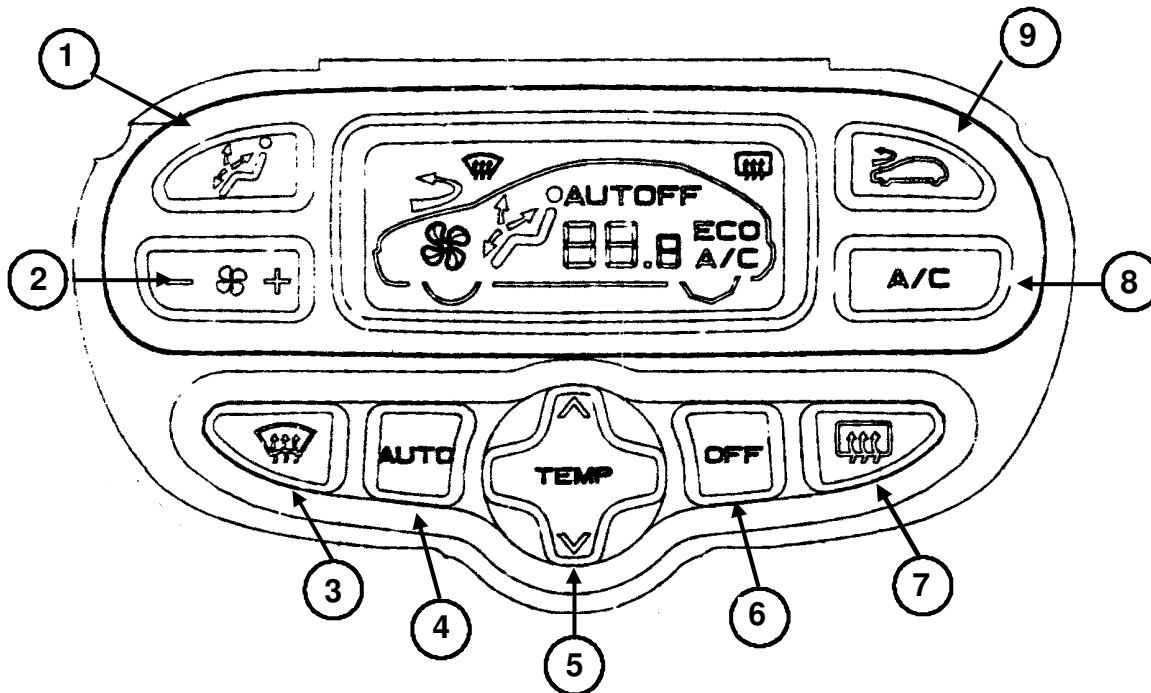

A - USER CONTROLS

N°	CONTROL	DESCRIPTION
1	Distribution	Used to adjust the distribution of air using one of the various preset flap positions (footwells, footwells-face, face, footwells-demisting, windscreen)
2	Blower motor	Controls the power of the air blower motor
3	Visibility	Switching to automatic mode aimed at visibility, when one of the parameters (except the blower motor) is adjusted manually, the other settings switch to AUTO mode
4	Auto	The system automatically controls the climate for the passengers, one of the parameters can be adjusted manually without affecting the other automatic settings.
5	Temperature	Allows the user to adjust the reference temperature
6	Off	Switches the system off
7	Rear de-icing	Heated rear screen de-icing request
8	A/C	Switches the air conditioning on or off (with ECO displayed on the display)
9	Air inlet	Used to recirculate air internally

MULTIPLEXED BSI - XSARA PICASSO AND XSARA – PART 8

B - DISPLAY

The display is incorporated into the air conditioning control panel. It is used for:

- viewing the user choices and system status,
- providing feedback about the actions performed to the user,
- warning of any system faults.

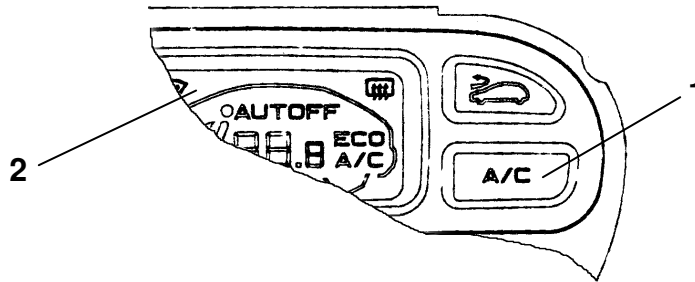

Brightness of the LEDs (1)

The displays have a fixed brightness by day which can be dimmed at night.

The symbols are only illuminated at night (with fixed brightness).

Display (2)

During night driving, the display is not lit. It illuminates for 10 seconds when any buttons on the control panel are operated.

Note: The Black Panel does not extinguish for as long as the heated rear screen and/or visibility are active.

MULTIPLEXED BSI - XSARA PICASSO AND XSARA – PART 8

OPERATING PRINCIPLE

I - COMPRESSOR MANAGEMENT FUNCTION

The compressor is controlled by the BSI. It takes into account:

- the compressor engaging request (A/C),
- the icing up safety of the evaporator,
- the air conditioning pressure,
- the engine speed,
- the engine coolant temperature,
- the dialogue with the engine management ECU.

A - COMPRESSOR ENGAGING REQUEST

The request to engage the compressor is sent from the air conditioning control panel to the compressor control management electronics via the VAN network.

Action	the request is taken into account
IF condition	the engine is running
AND condition	the blower motor is activated

B - EVAPORATOR ICING UP SAFETY DEVICE

The evaporator icing up safety device defines the rules for engaging and cutting off the compressor depending on:

- evaporator temperature,
- external temperature.

Evaporator temperature as a function of external temperature:

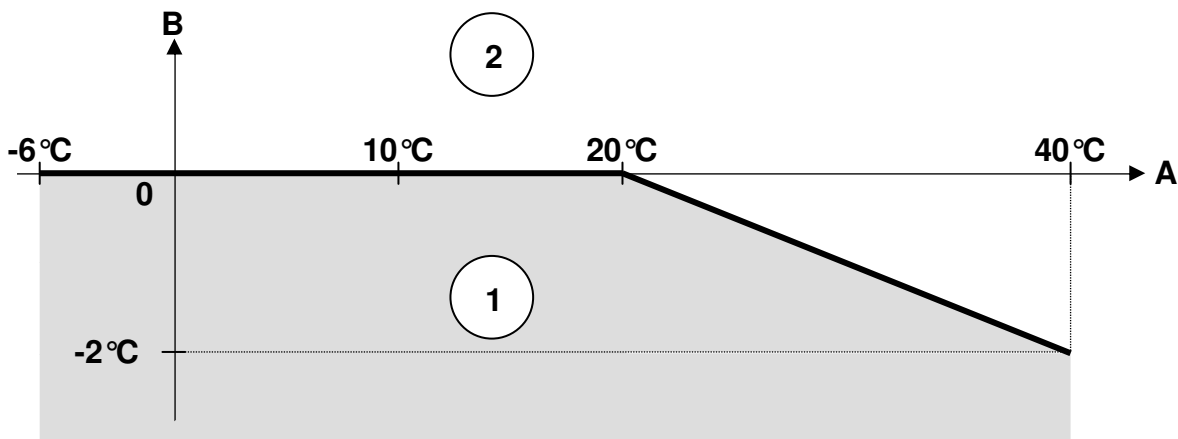

KEY	
A	External air temperature
B	Evaporator temperature
1	Compressor forbidden
2	Compressor authorised

MULTIPLEXED BSI - XSARA PICASSO AND XSARA – PART 8

C - AIR CONDITIONING PRESSURE SAFETY DEVICE

The BSI cuts off the compressor in the event of:

- high pressure (risk of damaging the circuit),
- low pressure (probability of a leak).

Detection is performed by a 4 level pressure switch.

To prevent the compressor from being successively engaged, waiting times are set:

COMPRESSOR CUT-OFF	WAITING TIME
1 st cut-off	1 minute
2 nd cut-off	4 minutes
3 rd and subsequent cut-offs	16 minutes

The timer is reset when the engine running information disappears.

D - ENGINE SPEED SAFETY DEVICE

To ensure the compressor is sufficiently protected at high engine speeds, a request to cut off the compressor is made if the engine speed is above 6250 rpm.

The compressor is authorised to re-engage if the engine speed falls below 5650 rpm. A cut-off time of at least 5 seconds is used.

Example: Engine speed as a function of time.

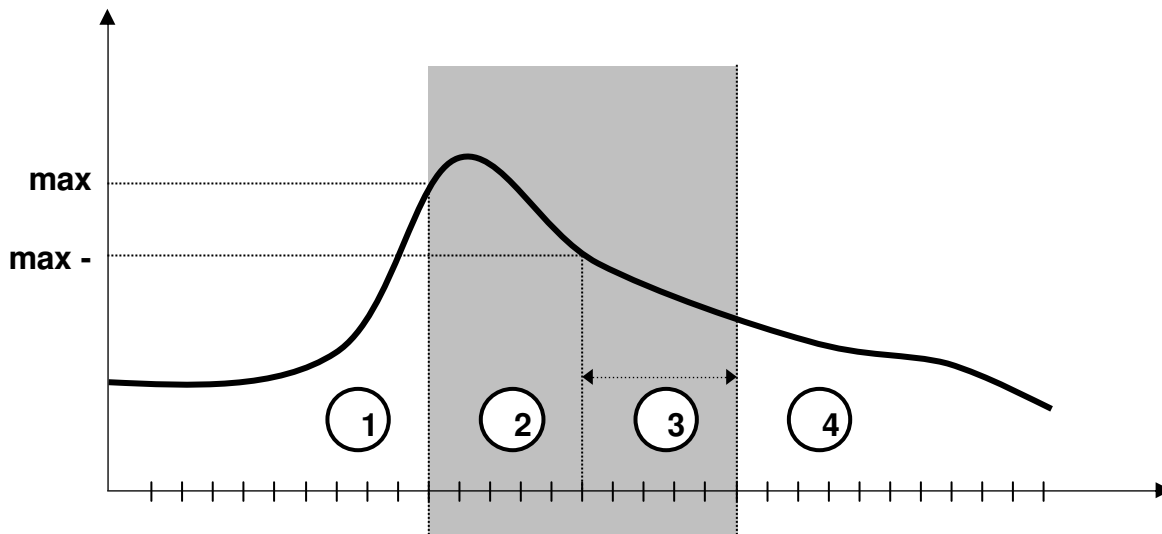

KEY	
max +	Engine speed = 6250 rpm
max -	Engine speed = 5650 rpm
	Compressor forbidden
1	Compressor engaged
2	Compressor cut-off
3	5 second timer before re-engaging
4	Compressor engaged

MULTIPLEXED BSI - XSARA PICASSO AND XSARA – PART 8

E - ENGINE COOLANT TEMPERATURE COMPRESSOR CONTROL

If the engine coolant temperature is too high, compressor operation is controlled by the BSI.

The compressor is forbidden for a coolant temperature above 112°C.

It is authorised to re-engage if the coolant temperature is below 109°C and if the previous cut-off due to coolant temperature was more than one minute ago.

Example: coolant temperature as a function of time.

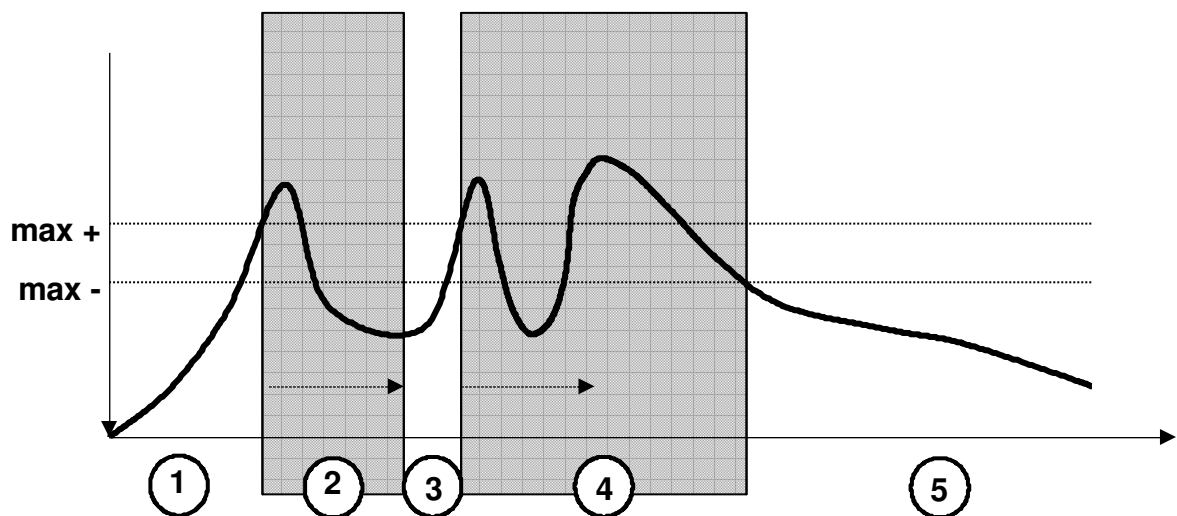

KEY	
max +	Coolant temperature = 112°
max -	Coolant temperature = 109°
	Compressor forbidden.
1	The compressor is engaged.
2	The maximum temperature has been exceeded: the compressor is cut off
3	The compressor is re-engaged as the temperature is valid after the one minute timer.
4	The maximum temperature has once again been exceeded: the compressor is cut off.
5	The compressor is re-engaged when the temperature returns to normal after more than one minute.

MULTIPLEXED BSI - XSARA PICASSO AND XSARA – PART 8

II - ADDITIONAL ELECTRIC HEATING FUNCTION

Function:

For DW10TD engines (HDi), heating resistors are placed in the engine cooling circuit. This allows a sufficient heat source to be obtained to operate the air conditioning, despite the slow rise in engine temperature.

Functional description:

The engine ECU requests the additional heating depending on the following information:

- coolant temperature,
- external temperature (through engine inlet).

Note: an additional heater is available as an option.

III - DE-ICING FUNCTION

Function:

To de-ice the heated rear screen and the heated door mirrors depending on:

- user request,
- energy management (12 minute timer),
- engine running information.

Functional description:

Action	De-icing of the rear screen and door mirrors for 12 minutes
IF condition	The user requests de-icing
AND condition	The engine is running
Display	Illumination of the de-icing LED

Case of switching off the engine during the timer

- If the engine is started again within one minute after switching it off:
De-icing is reactivated to finish the timer.
- If the engine is started again more than one minute after switching it off:
De-icing is not reactivated.

MULTIPLEXED BSI - XSARA PICASSO AND XSARA – PART 8

IV - DOWNGRADED MODES

Faults in the components below lead to a system operation which, depending on the case:

- bypasses the faulty component,
- prevents certain functions.

An ECU considers there to be a fault when the value transmitted by one of the components is outside fixed limits. These values are set for normal vehicle usage, plus a certain margin.

FAULT ORIGIN	BEHAVIOUR ADOPTED
Evaporator temperature sensor.	Compressor prevented from engaging.
External temperature sensor.	The compressor cut-off only depends on the evaporator temperature, with a suitable limit.
Air conditioning pressure sensor.	Compressor prevented from engaging.
Coolant temperature information.	Compressor prevented from engaging.

V - DIAGNOSTICS

Below are the components which can undergo a diagnostic procedure and the data received:

COMPONENT ACCESSIBLE BY DIAGNOSTICS	DATA RECEIVED
Evaporator sensor output	Open circuit Short circuit
Air conditioning pressure safety input	Short circuit to earth
Air conditioning pressure signal	Open circuit Signal validity
Coolant temperature range	Open circuit (TU5JP) Short circuit (TU5JP) Broken connection (EW7J4 and DW10TD) Signal outside range (EW7J4 and DW10TD)
Compressor engaging request (BSI to engine ECU)	Signal value Short circuit to +12V
Compressor engaging authorisation (engine ECU to BSI)	Signal value
Compressor control output	Open circuit Short circuit to earth

MULTIPLEXED BSI - XSARA PICASSO AND XSARA – PART 8

ELECTRICITY

I - LAYOUT DIAGRAM - TU5JP

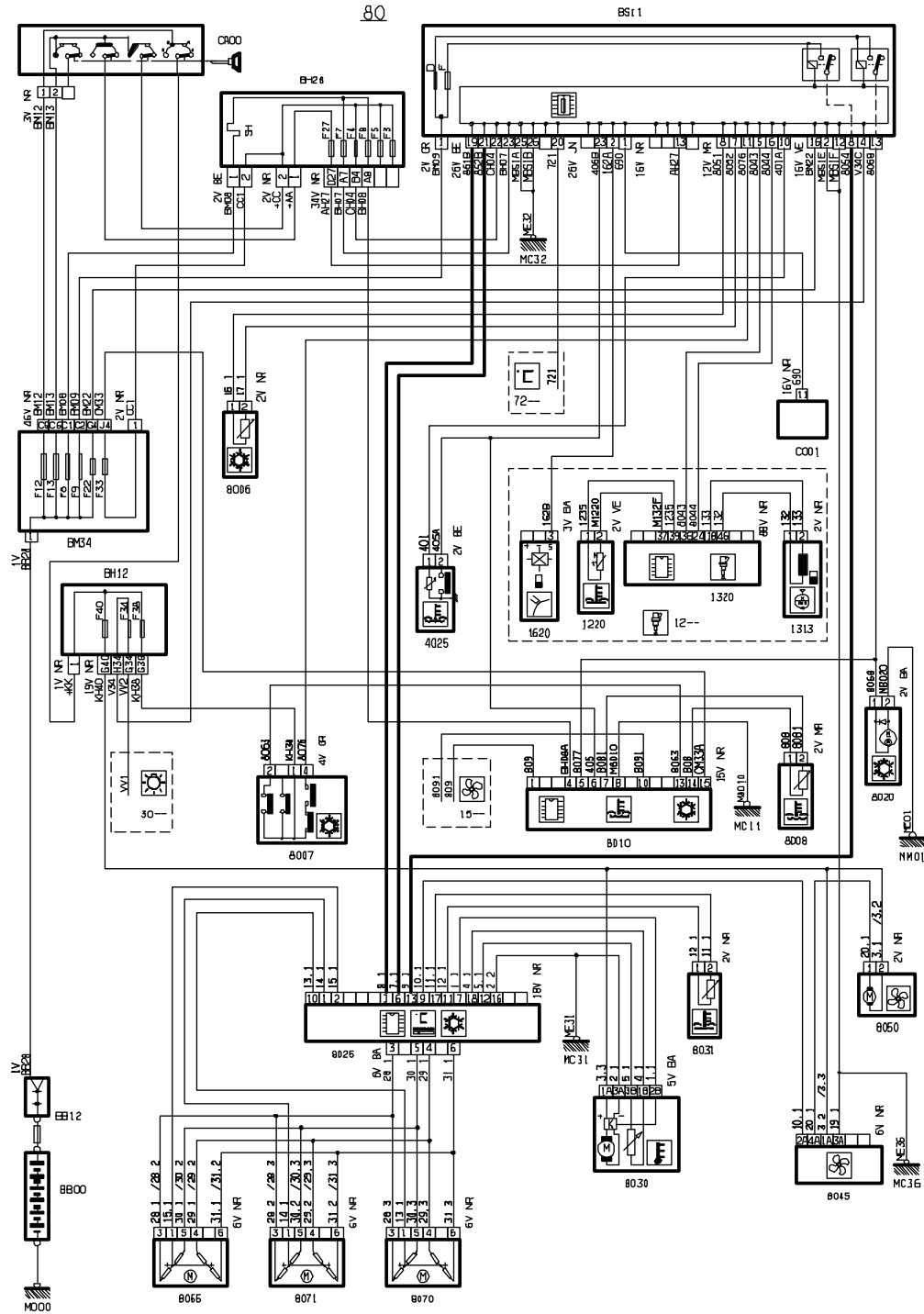

PFM008P

MULTIPLEXED BSI - XSARA PICASSO AND XSARA – PART 8

III - LAYOUT DIAGRAM - EW7

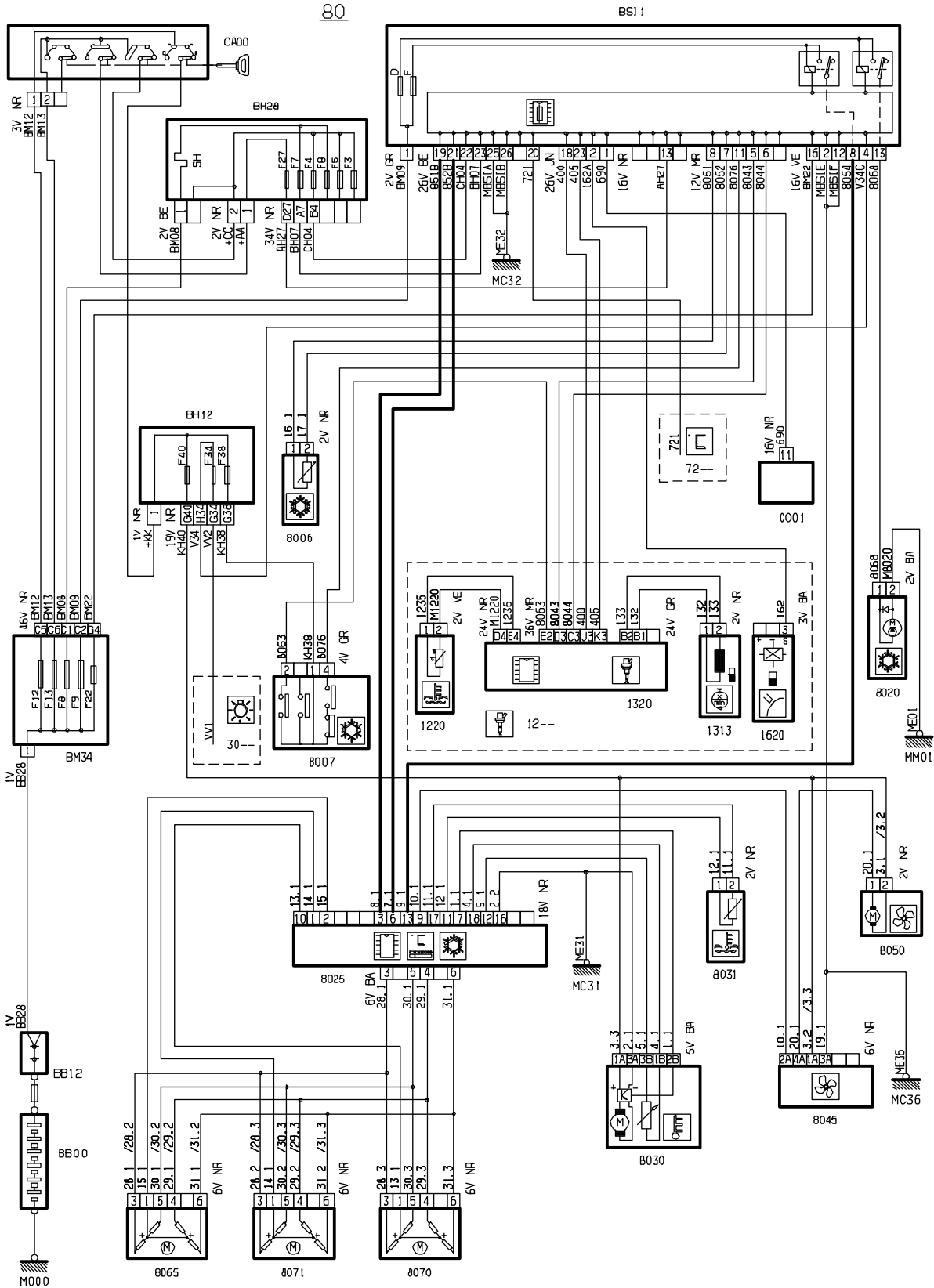

PFM009P

MULTIPLEXED BSI - XSARA PICASSO AND XSARA – PART 8

V - LAYOUT DIAGRAM - DW10

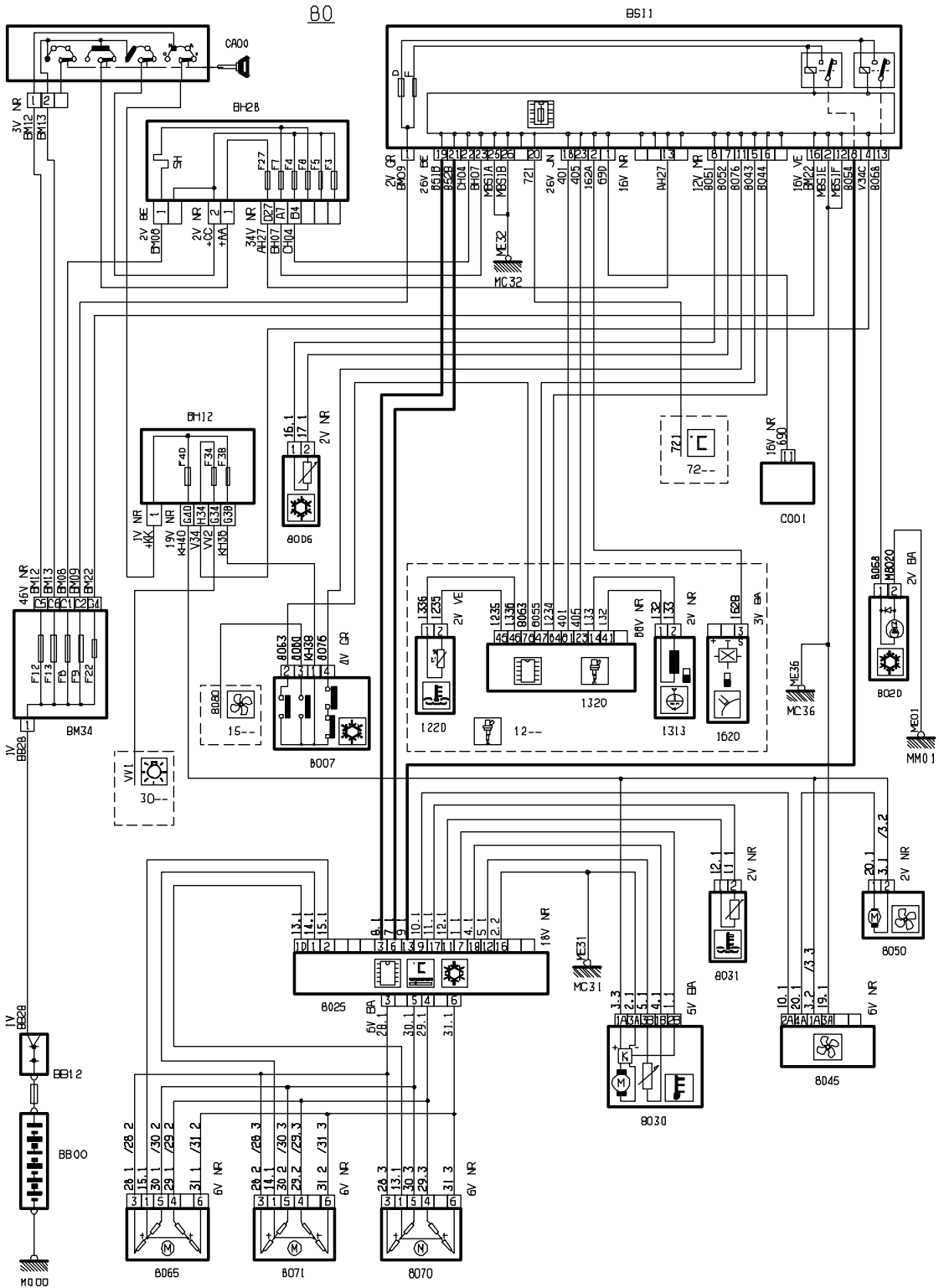

PFM010P

MULTIPLEXED BSI - XSARA PICASSO AND XSARA – PART 8

IV - PARTS LIST

- BB00 - Battery
- BB12 - + battery connection terminal
- BH12 - 12 fuse box (passenger compartment)
- BH28 - 28 fuse box (passenger compartment)
- BM34 - 34 fuse engine relay unit
- BSI1 - Built-in systems interface
- C001 - Diagnostic connector
- CA00 - Ignition switch
- CT00 - Rotary connector
- 0002 - Signalling/lighting stalk
- 0004 - Control panel
- 0005 - Wiper stalk
- 1010 - Starter motor
- 1020 - Alternator
- 1203 - Inertia switch
- 1211 - Fuel sender pump
- 1220 - Engine coolant temperature sensor
- 1313 - Engine speed sensor
- 1320 - Engine management ECU
- 1620 - Vehicle speed sensor
- 2300 - Danger signal switch
- 2340 - Left hand side repeater
- 2345 - Right hand side repeater
- 2610 - Left hand headlamp
- 2615 - Right hand headlamp
- 2630 - Rear left hand lamp on body
- 2635 - Rear right hand lamp on body
- 3010 - Front interior lamp
- 3020 - Rear interior lamp
- 3050 - Lighting rheostat
- 3054 - Ashtray lighting
- 3105 - Boot (or tailgate) lighting

MULTIPLEXED BSI - XSARA PICASSO AND XSARA – PART 8

- 3110 - Glove box lighting switch
- 3115 - Glove box lighting
- 4010 - Engine coolant level switch
- 4025 - Temperature sensor - engine coolant thermostats (gauge)
- 5015 - Windscreen wiper motor
- 5115 - Windscreen/rear screen washer pump
- 6202 - Front door lock assembly driver's side
- 6207 - Front door lock assembly passenger's side
- 6260 - Boot locking motor
- 8006 - Evaporator thermistor (if separate)
- 8007 - Pressure switch
- 8008 - Air conditioning engine coolant temperature thermistor
- 8010 - Coolant temperature unit
- 8020 - Air conditioning compressor
- 8025 - Air conditioning control panel (if separate)
- 8030 - Passenger compartment air thermistor
- 8031 - Coolant thermistor
- 8045 - Blower control module (if separate)
- 8050 - Blower motor (if separate)
- 8065 - Mixing flap reduction motor
- 8070 - Air input flap reduction motor
- 8071 - Distribution flap reduction motor
- 8220 - Analogue module transponder
- 8410 - Radio
- 8413 - Radio control
- 8415 - Compact disc changer
- 8420 - Loud speakers on front door (driver's side)
- 8425 - Loud speakers on front door (passenger's side)
- 8430 - Loud speaker (rear left hand)
- 8435 - Loud speaker (rear right hand)
- 8440 - Front left hand tweeter speaker
- 8445 - Front right hand tweeter speaker
- 8500 - Navigation ECU

MULTIPLEXED BSI - XSARA PICASSO AND XSARA – PART 8

MULTIPLEXED BSI - XSARA PICASSO AND XSARA – PART 8

PART 9

VEHICLE IMMOBILISATION
XSARA AND XSARA PICASSO

MULTIPLEXED BSI - XSARA PICASSO AND XSARA – PART 9

TRANSPONDER SYSTEM OPERATING PRINCIPLE

I - FOREWORD

The role of this function is to protect the vehicle:

- by electronically locking the engine management ECU - on petrol and HDi engines,
- by electronically locking the diesel pump electrovalve - on XUD engines.

The system consists of:



- an analogue unit located in the top of the ignition switch,
- a responder label located in the ignition key,
- a Built-in Systems Interface (BSI) which authorises unlocking or not,
- an engine management ECU or a diesel pump electrovalve (depending on engine),
- a Multifunction Screen (MFS) for displaying messages (XSARA PICASSO only).

Note: For simplification purposes, only petrol and HDI engines are dealt with as the general operation is the same for XUD engines.

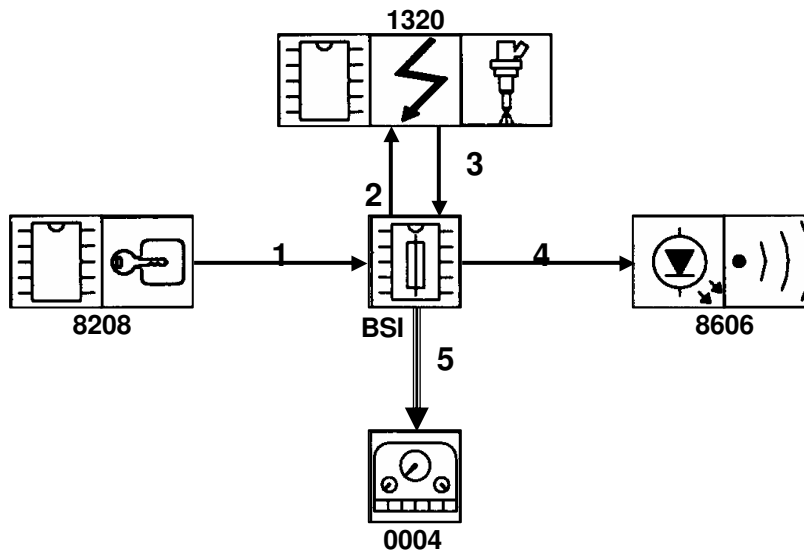
II - GENERAL LAYOUT



Key:

 single arrow = wire connection
 triple arrow = multiplexed connection

COMPONENTS	
BSI	Built-in Systems Interface (BSI)
0004	Multifunction Screen (MFS)
1320	Engine management ECU
8208	Key-transponder assembly
8606	"System status" LED

CONNECTIONS		
n°	Signal	Type
1	Position of the ignition key	All or nothing
	Encrypted code	Analogue
2	Engine ECU locking or unlocking control	Digital
3	Engine ECU locking status	Digital
4	Vehicle immobilisation status	All or nothing
5	Fault message to be displayed	VAN

MULTIPLEXED BSI - XSARA PICASSO AND XSARA – PART 9

III - OPERATION

A - SYSTEM COMPONENTS

Transponder:

An analogue unit, located in the top of the ignition switch, sends a signal to the ignition key. This is fitted with a responder label which disrupts the signal emitted by the analogue unit. The modification to the signal allows the analogue unit to transmit the key code (responder label) to the BSI.

Built-in Systems Interface:

The BSI decodes the signal sent by the label. It considers the key to be valid or not, depending on the signal received from the key.

It then controls the display on the MultiFunction Screen (XSARA PICASSO) or on the control panel (XSARA) and the locking/unlocking of the engine management ECU.

Engine management ECU:

This can be locked or unlocked by the BSI. When locked, its functions are prohibited (ignition, injection, etc). On diesel engine vehicles, the diesel pump electrovalve is locked in the same way.

MultiFunction Screen (XSARA PICASSO only):

This displays the message "ENGINE IMMOBILISER FAULT" if it was not possible to unlock the engine.

Case of engine locked: There is a communications problem or the engine ECU has not unlocked itself after receiving the request from the BSI.

Case of unknown transponder: The key has not been recognised or has not been reprogrammed after the last programming.

Control panel (XSARA only):

There is an LED on the control panel which shows the status of the transponder.

MULTIPLEXED BSI - XSARA PICASSO AND XSARA – PART 9

B - LOCKING FUNCTION

Functional description:

ACTION	THE BSI CONTROLS LOCKING
IF condition	the key is removed from the ignition switch
	AND the ignition has been off for > 10 secs.
OR condition	the key is in the OFF position
	AND the ignition has been off for > 2 mins.

C - UNLOCKING FUNCTION

Functional description:

FUNCTION	THE BSI CONTROLS UNLOCKING
IF condition	the key is present
AND condition	the key is recognised
AND condition	the ignition is on

MULTIPLEXED BSI - XSARA PICASSO AND XSARA – PART 9

OPERATING PRINCIPLE OF THE FACTORY FITTED ANTI-INTRUSION ALARM

I - FOREWORD

*Note: The factory fitted alarm is **only available on the XSARA.***

The role of this function is to protect the vehicle against intrusions. Protection is provided by *Perimetric and Volumetric* monitoring.

This alarm is not multiplexed as it is inside the BSI. All the sensors and actuators for this function are therefore connected *directly* to the unit.

II - GENERAL LAYOUT

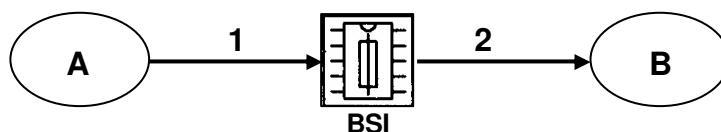

COMPONENTS	
A	Door, bonnet and boot switches
	Volumetric suppression button
	Ultra sound unit
	HF remote control
B	Indicators and side repeaters
	System status LED
	Siren
	Ultra sound unit
	Display LED

CONNECTIONS		
n°	Signal	Type
1	Door status information	All or nothing
	Volumetric suppression request	All or nothing
	Siren prohibition request	All or nothing
	Intrusion information by volumetric monitoring	All or nothing
	Locking / unlocking request	HF
2	Indicators and side repeaters control	All or nothing
	Siren control	Serial connection
	Ultra sound unit control	Supply
	LED control	All or nothing

MULTIPLEXED BSI - XSARA PICASSO AND XSARA – PART 9

III - OPERATION

A - OPERATING MODES

The anti-intrusion alarm has 3 operating modes:

MODE	DESCRIPTION
Armed mode	Vehicle protected
Disarmed mode	Vehicle not protected
Triggered mode	Signalling an intrusion

B - ARMING / DISARMING

Arming

The vehicle is protected only when it is deadlocked using the HF remote control.

When armed, an intrusion or cutting the supply will cause the alarm to be triggered for 30 seconds. At the end of this time, or when the supply is reconnected, the alarm returns to the armed state.

Disarming

Whether the alarm is triggered or not, the alarm is disarmed by:

- unlocking the vehicle with the HF remote control,
- the key being recognised when the ignition is switched on (after unlocking with the key).

C - PERIMETRIC PROTECTION

This protection monitors:

- the doors,
- the boot,
- the bonnet,
- the + accessories position,
- the + ignition on position,
- the + battery position.

Perimetric protection is active 5 seconds after the alarm is armed.

Case of one of the doors or boot or bonnet not correctly closed

- The siren emits a sound for 0.2 seconds.
- A timer is started: the user has 45 seconds to close the door, boot or bonnet. After this, perimetric monitoring is active.

Triggering perimetric protection

ACTION	TRIGGERING OF THE ALARM
IF condition	change in status of one of the doors, boot or bonnet
OR condition	disappearance of the + battery
OR condition	ignition switched on

D - VOLUMETRIC PROTECTION

This protection monitors the volume of the passenger compartment. It is active 45 seconds after the alarm is armed.

1 - Triggering volumetric protection:

An intrusion is detected by the ultra sound sensor module. All significant variations in passenger compartment volume trigger the alarm.

a - Prohibiting volumetric protection

- Voluntary prohibition

After the ignition is switched off, this protection can be prohibited voluntarily, by pressing the volumetric suppression switch for at least 1 second. This request must be made within 5 minutes before the alarm is armed, otherwise it is ignored.

- Automatic prohibition

Volumetric protection is prohibited after the alarm has been triggered 3 times within the same arming period.

E - TRIGGERING THE ALARM

If an intrusion attempt is detected when the alarm is armed, the alarm will:

- operate the self powered alarm for 30 seconds,
- operate the indicators and side repeaters,
- memorise the fact that the alarm has been triggered,
- count the number of times the alarm has been triggered due to the volumetric protection.

After 30 seconds, the alarm returns to armed mode. It can only be triggered again after being armed for at least 5 seconds.

The case of the supply being cut is controlled directly by the self powered siren.

F - PROHIBITING THE SIREN

The siren can be prohibited by pressing the volumetric suppression switch for at least 2 seconds, within 10 seconds after the ignition is switched on.

MULTIPLEXED BSI - XSARA PICASSO AND XSARA – PART 9

OPERATING PRINCIPLE OF THE AFTER-SALES FITTED ANTI-INTRUSION ALARM

I - FOREWORD



The aim of this function is to be able to incorporate an after-sales anti-theft alarm into the vehicle (Xsara or Xsara Picasso). The BSI communicates with the alarm unit via the VAN network.

This alarm offers the same protection as the factory fitted alarm (optional on the XSARA).

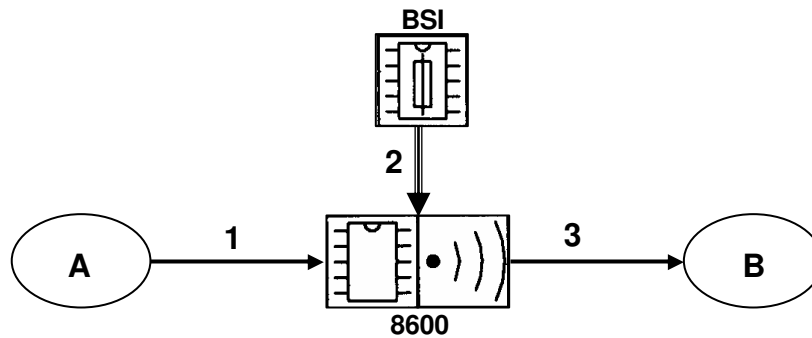
II - GENERAL LAYOUT



Key:

 single arrow = wire connection
 triple arrow = multiplexed connection

COMPONENTS	
BSI	Built-in Systems Interface
8600	Autonomous alarm unit
A	Boot opening switch (Xsara only)
	Bonnet opening switch
	Volumetric suppression button
	Ultra sound sensors
	Connector to the BSI controlling the interior lamps
	Ignition switch
B	Indicators and side repeaters
	Siren
	Display LED

CONNECTIONS		
n°	Signal	Type
1	Information about the status of the doors, boot and bonnet	All or nothing
	Volumetric suppression request	All or nothing
	Information about modification to pass. comp. volume	All or nothing
	+ ignition on signal	All or nothing
2	Request to arm or disarm the alarm	VAN
3	Indicators control	All or nothing
	Siren control	All or nothing
	Display LED control	All or nothing
	Siren supply	Supply

MULTIPLEXED BSI - XSARA PICASSO AND XSARA – PART 9

III - OPERATION

A - PERIMETRIC PROTECTION

The information about the status of the doors, bonnet and boot is acquired by the interior lamp control: if, after a time, the interior lamp or lamps are extinguished, the vehicle is considered to be closed.

If the bulbs in the interior lamps are missing or faulty, the alarm is not affected: the information is taken from the command sent by the BSI.

If a door remains open after the alarm is armed, the siren sounds for 30 seconds, up to 10 consecutive times. It is no longer triggered after this.

B - VOLUMETRIC PROTECTION

Volumetric protection is active 45 seconds after the alarm is armed.

If movements are detected before the end of this timer, volumetric activation is delayed, several times if necessary.

Volumetric protection can be prohibited in the same way as for the factory fitted alarm.

Note: Tests on the volumetric protection must be performed with the doors and windows closed.

C - DISPLAY

An LED for this purpose is incorporated into the dashboard.

The LED operates in the same way for both vehicles:

STATUS	DISPLAY
Armed	flashing at 1 Hz
Volumetric protection prohibition	permanently illuminated until armed
Siren triggering prohibition	flashing at 1 Hz when armed
Triggering	flashing when monitoring is disarmed, until the memory is erased.

MULTIPLEXED BSI - XSARA PICASSO AND XSARA – PART 9

2 - Arming

The LED flashes during the volumetric protection timer at a frequency of 25 Hz, then at a frequency of 1 Hz until it is disarmed. If volumetric protection is cancelled, the LED flashes immediately at a frequency of 1 Hz until it is activated.

a - Triggering

To view the reason why the alarm was last triggered, the vehicle must be locked and then unlocked quickly. The LED flashes in accordance with the table below:

REASON FOR TRIGGERING	NUMBER OF FLASHES
Volumetric	2
Opening of doors	3
Opening of boot	5
Opening of bonnet	6
Attempt to start engine	7

D - SPECIFIC OPERATIONS

IMPORTANT: When fitting an after-sales alarm, the BSI must be programmed to prevent the indicators from being controlled when the doors are locked/unlocked. In this case, the alarm controls signalling.

Opening the vehicle with the key:

If the vehicle is opened using the key, the alarm is triggered. To disarm the alarm, the following procedure must be performed: enter the "EMERGENCY CODE".

Entering the "EMERGENCY CODE":

A 5 figure code is given on a card supplied with the alarm system. Example: 43125.

STEP	ACTION	EFFECT
1	Open the door.	The siren is set off.
2	Switch on the ignition.	
3	Switch off the ignition immediately.	
4	Switch on the ignition immediately.	
5	Allow the LED to flash 4 times (1 st figure of the code).	
6	Switch off the ignition.	The siren stops.

Repeat the procedure from step 2 to step 6 for the other 4 figures. If the code is recognised, the alarm is disarmed.

MULTIPLEXED BSI - XSARA PICASSO AND XSARA – PART 9

Fitting / removing the alarm:

When fitting the alarm, disconnect the battery. After the operation:

- Reconnect the battery,
- Enter the "EMERGENCY CODE",
- Switch on the ignition for 10 seconds,
- Switch off the ignition.

The siren is activated.

IMPORTANT: When working on the alarm, the battery must be disconnected throughout the operation.

Switching off the self powered siren:

- Disarm the alarm,
- Disconnect the connector from the siren.

Diagnostic:

Diagnostics cannot be performed on the autonomous after-sales fitted alarm and it must be disconnected during the diagnostics procedure.

IMPORTANT: When performing diagnostics on the vehicle, the after-sales alarm must be disconnected.

OPERATING PRINCIPLE OF THE SYSTEM STATUS LED

Note: The system status LED is only fitted on the XSARA PICASSO.

I - FUNCTION

Visible from the outside of the vehicle, the system status LED is used to view the protection status of the vehicle depending on:

- the locking status of the vehicle
- the immobiliser system

II - FUNCTIONAL DESCRIPTION

A - CONDITION ABOUT THE LOCKING STATUS OF THE VEHICLE

ACTION	VIEWING THE LOCKING STATUS OF THE VEHICLE
IF condition	the vehicle is locked or deadlocked
AND condition	the ignition is off

B - CONDITION ABOUT THE STATUS OF THE IMMOBILISER SYSTEM

ACTION	VIEWING THE STATUS OF THE IMMOBILISER SYSTEM
IF condition	the key is missing
AND condition	the engine management ECU is locked

C - DISPLAY OF THE 2 PREVIOUS STATUSES

When the 2 previous statuses are fulfilled, the BSI controls the flashing of the LED (frequency 1 Hz, cyclic ratio 1/20).

ELECTRICITY

I - LAYOUT DIAGRAM

TRANSPONDER

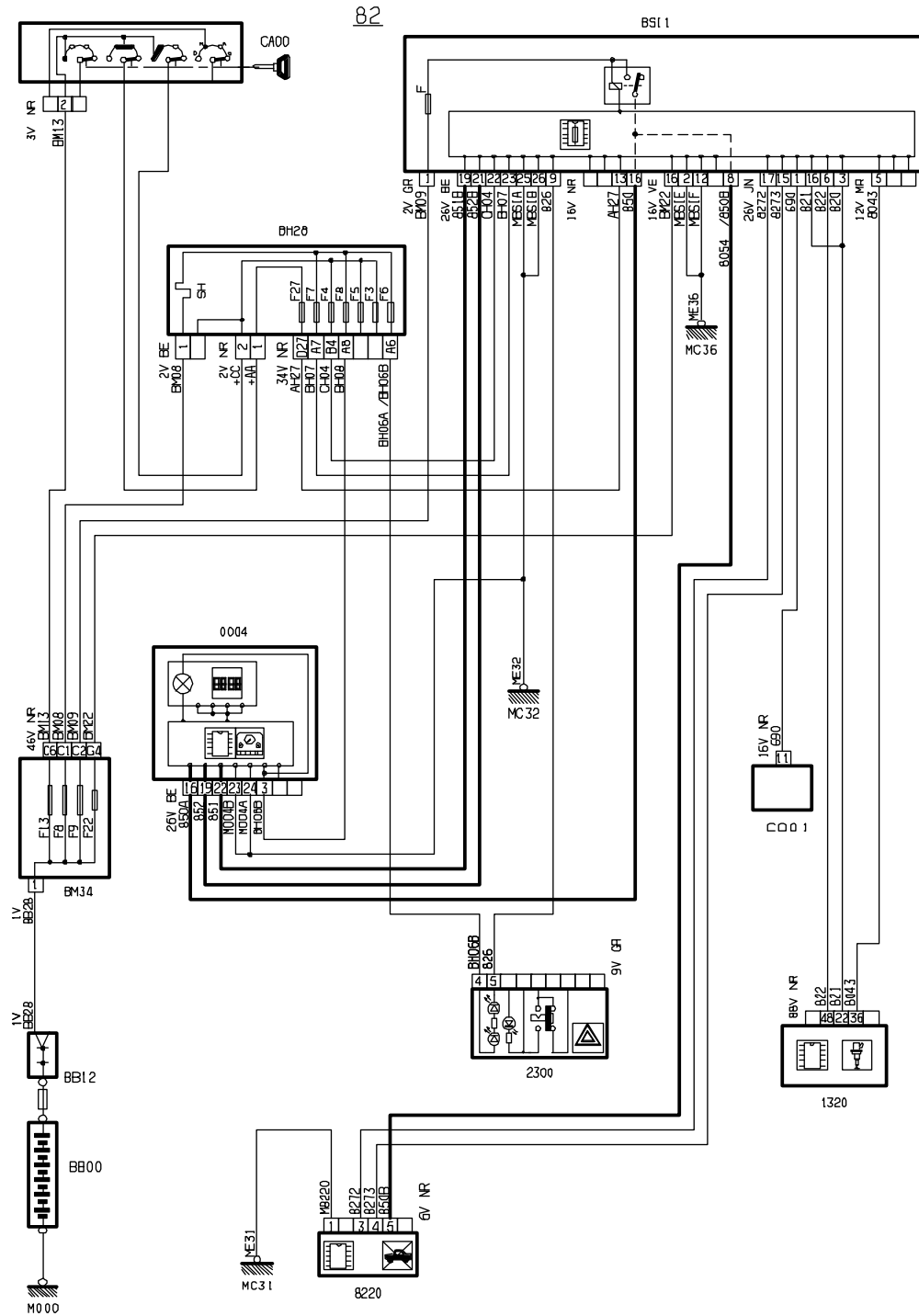

PFM011P

MULTIPLEXED BSI - XSARA PICASSO AND XSARA – PART 9

II - PARTS LIST

- BB00 - Battery
- BB12 - + battery connection terminal
- BH12 - 12 fuse box (passenger compartment)
- BH28 - 28 fuse box (passenger compartment)
- BM34 - 34 fuse engine relay unit
- BSI1 - Built-in systems interface
- C001 - Diagnostic connector
- CA00 - Ignition switch
- CT00 - Rotary connector
- 0002 - Signalling/lighting stalk
- 0004 - Control panel
- 0005 - Wiper stalk
- 1010 - Starter motor
- 1020 - Alternator
- 1203 - Inertia switch
- 1211 - Fuel sender pump
- 1220 - Engine coolant temperature sensor
- 1313 - Engine speed sensor
- 1320 - Engine management ECU
- 1620 - Vehicle speed sensor
- 2300 - Danger signal switch
- 2340 - Left hand side repeater
- 2345 - Right hand side repeater
- 2610 - Left hand headlamp
- 2615 - Right hand headlamp
- 2630 - Rear left hand lamp on body
- 2635 - Rear right hand lamp on body
- 3010 - Front interior lamp
- 3020 - Rear interior lamp
- 3050 - Lighting rheostat
- 3054 - Ashtray lighting
- 3105 - Boot (or tailgate) lighting

MULTIPLEXED BSI - XSARA PICASSO AND XSARA – PART 9

- 3110 - Glove box lighting switch
- 3115 - Glove box lighting
- 4010 - Engine coolant level switch
- 4025 - Temperature sensor - engine coolant thermostats (gauge)
- 5015 - Windscreen wiper motor
- 5115 - Windscreen/rear screen washer pump
- 6202 - Front door lock assembly driver's side
- 6207 - Front door lock assembly passenger's side
- 6260 - Boot locking motor
- 8006 - Evaporator thermistor (if separate)
- 8007 - Pressure switch
- 8008 - Air conditioning engine coolant temperature thermistor
- 8010 - Coolant temperature unit
- 8020 - Air conditioning compressor
- 8025 - Air conditioning control panel (if separate)
- 8030 - Passenger compartment air thermistor
- 8031 - Coolant thermistor
- 8045 - Blower control module (if separate)
- 8050 - Blower motor (if separate)
- 8065 - Mixing flap reduction motor
- 8070 - Air input flap reduction motor
- 8071 - Distribution flap reduction motor
- 8220 - Analogue module transponder
- 8410 - Radio
- 8413 - Radio control
- 8415 - Compact disc changer
- 8420 - Loud speakers on front door (driver's side)
- 8425 - Loud speakers on front door (passenger's side)
- 8430 - Loud speaker (rear left hand)
- 8435 - Loud speaker (rear right hand)
- 8440 - Front left hand tweeter speaker
- 8445 - Front right hand tweeter speaker
- 8500 - Navigation ECU

MULTIPLEXED BSI - XSARA PICASSO AND XSARA – PART 9

MULTIPLEXED BSI - XSARA PICASSO AND XSARA – PART 9

PART 10

RADIO AND COMPACT DISC CHANGER

XSARA PICASSO

MULTIPLEXED BSI - XSARA PICASSO AND XSARA – PART 10

GENERAL

I - FOREWORD

The XSARA PICASSO has 2 types of radio:

RB2 = Radio receiver fitted with a Basic mechanical cassette plate with split screen

RD2 = Radio receiver fitted with a Compact Disc player with split screen

- They have a split screen located in the control panel.
- They receive operating requests from the MultiFunction Screen for the functions performed using the remote controls at the steering wheel.
- All information relating to the display is communicated to the network and controlled by the screen.

Note: All radios can be fitted with a Compact Disc Changer (CDC).

The only compatible CD changer is the 6 disc changer available as a CITROËN accessory.

Note: Only engraved CDs can be read.

Configuration:

The following parameters can be configured using the diagnostics tool:

- Fader deactivated / activated.
- Geographical areas for the TUNER.
- Volume automatically linked to speed (RD2 and RB2).
- HI-FI version (activation of the output line) or not.

When leaving the **FACTORY** / in after-sales (= supplier **FACTORY** exit configuration), the radios are configured as followed:

- Fader active.
- TUNER: Western Europe.
- Volume automatically linked to speed: OFF.
- Hi-Fi version for RD2, non Hi-fi for RB2.

II - GENERAL LAYOUT

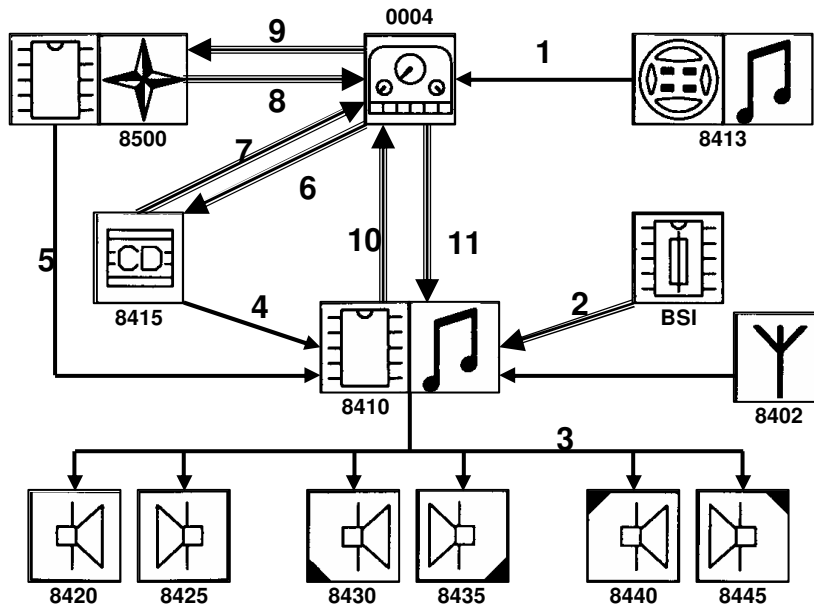

Key:
 —————> single arrow = wire connection
 ≡≡≡> triple arrow = multiplexed connection

COMPONENTS			
BSI	Built-in Systems Interface	8420	Speaker on front left hand door
0004	MultiFunction Screen	8425	Speaker on front right hand door
8402	Aerial	8430	Speaker on rear left hand door
8410	Radio	8435	Speaker on rear right hand door
8413	Steering wheel remote control	8440	Front left hand tweeter
8415	CD changer	8445	Front right hand tweeter
8500	Navigation		

MULTIPLEXED BSI - XSARA PICASSO AND XSARA – PART 10

CONNECTIONS		
n°	Signal	Type
1	Request to change radio and CD changer status	All or nothing
2	Vehicle speed + VIN + brightness/contrast level	VAN
3	Output signal (possibly function of vehicle speed)	Analogue
4	CD audio input	Analogue
5	Navigation audio input	Analogue
6	Change of status of CD changer	VAN
7	CD changer status	VAN
8	Navigation status	VAN
9	Change of status of navigation	VAN
10	Radio status	VAN
11	Change in status of radio	VAN

MULTIPLEXED BSI - XSARA PICASSO AND XSARA – PART 10

RADIO OPERATING PRINCIPLE

I - SWITCHING ON / OFF

A - GENERAL DESCRIPTION

The radio is switched on and off by:

- pressing the "ON" button on the front of the radio,
- switching the ignition on or off*,
- inserting a CD when the + accessories is present (RD2).

* If the radio was on before the ignition was switched off (vehicle stationary), the radio will work when the + accessories reappears.

B - SUPPLY MANAGEMENT

The MultiFunction Screen controls the supply to the radio:

- When the +VAN is present.

The radio sends on and off requests to the MultiFunction Screen.

The MultiFunction screen decides whether to switch the radio on or off, depending on the case.

- When the +VAN is missing.

The radio can wake up the VAN network to request that it be switched on. It switches itself off after a 30 minute timer.

II - RADIO ANTI-THEFT FUNCTION

The radios do not have an LED which flashes when the vehicle is stationary.

The anti-theft protection device is provided in the form of an identification code. It consists of the last 8 characters of the VIN, memorised by the BSI and the radio.

Note: Radios are supplied by the Replacement Parts Division with a memorised VIN code.

When operating, the radio's VIN code is compared with that of the BSI. If they do not correspond, the radio switches to scrambled mode.

Note: The VIN code cannot be reprogrammed in the BSI.

Consequently, the radio VIN code must be changed using the diagnostics tool if a new radio is fitted.

III - CONTROLLING THE BRIGHTNESS

The RD2 alters its brightness as a function of the value given by the BSI.

The brightness of the RB2 cannot be adjusted.

IV - VOLUME AUTOMATICALLY LINKED TO VEHICLE SPEED

RB2 and RD2 radios automatically correct the volume as a function of speed if the following 2 conditions are fulfilled:

- the configuration via the "Volume automatically linked to speed" diagnostic is ON,
- the user has activated, via the radio menu, the automatic volume correction (VOLUME_AUTO = ON).

This function does not affect the volume displayed on the screen and is controlled within the radio.

Note: The values of the volume are transmitted to the multifunction screen during adjustment.

It is still possible to adjust the volume manually using the "ON/VOL" button or the steering wheel remote control at any time and is independent to automatic correction.

MULTIPLEXED BSI - XSARA PICASSO AND XSARA – PART 10

V - THERMAL PROTECTION

The radios have dynamic maximum volume limitation strategies, which depend on the rise in temperature in the units.

Note: RD2 radios limit the volume without altering the volume displayed on the screen.

RB2 radios only display the change in volume if the user performs a voluntary action (reduction in maximum volume from 30 to xx).

VI - CONFIGURATION

All new systems which have not been programmed will not be recognised by the system and will therefore not work. It is therefore essential to declare all radios and/or CD changers which are added or removed. All programming procedures require the use of a diagnostics tool. They must be performed on the vehicle.

ACCESSORIES	CONFIGURATION IN THE EVENT OF ADDING/REMOVING
CD changer	Configuration of control panel + BSI
Factory fitted radio	Configuration of control panel + BSI

MULTIPLEXED BSI - XSARA PICASSO AND XSARA – PART 10

ELECTRICITY

I - LAYOUT DIAGRAM

MULTIPLEXED BSI - XSARA PICASSO AND XSARA – PART 10

II - PARTS LIST

- BB00 - Battery
- BB12 - + battery connection terminal
- BH12 - 12 fuse box (passenger compartment)
- BH28 - 28 fuse box (passenger compartment)
- BM34 - 34 fuse engine relay unit
- BSI1 - Built-in systems interface
- C001 - Diagnostic connector
- CA00 - Ignition switch
- CT00 - Rotary connector
- 0002 - Signalling/lighting stalk
- 0004 - Control panel
- 0005 - Wiper stalk
- 1010 - Starter motor
- 1020 - Alternator
- 1203 - Inertia switch
- 1211 - Fuel sender pump
- 1220 - Engine coolant temperature sensor
- 1313 - Engine speed sensor
- 1320 - Engine management ECU
- 1620 - Vehicle speed sensor
- 2300 - Danger signal switch
- 2340 - Left hand side repeater
- 2345 - Right hand side repeater
- 2610 - Left hand headlamp
- 2615 - Right hand headlamp
- 2630 - Rear left hand lamp on body
- 2635 - Rear right hand lamp on body
- 3010 - Front interior lamp
- 3020 - Rear interior lamp
- 3050 - Lighting rheostat
- 3054 - Ashtray lighting
- 3105 - Boot (or tailgate) lighting

MULTIPLEXED BSI - XSARA PICASSO AND XSARA – PART 10

- 3110 - Glove box lighting switch
- 3115 - Glove box lighting
- 4010 - Engine coolant level switch
- 4025 - Temperature sensor - engine coolant thermostats (gauge)
- 5015 - Windscreen wiper motor
- 5115 - Windscreen/rear screen washer pump
- 6202 - Front door lock assembly driver's side
- 6207 - Front door lock assembly passenger's side
- 6260 - Boot locking motor
- 8006 - Evaporator thermistor (if separate)
- 8007 - Pressure switch
- 8008 - Air conditioning engine coolant temperature thermistor
- 8010 - Coolant temperature unit
- 8020 - Air conditioning compressor
- 8025 - Air conditioning control panel (if separate)
- 8030 - Passenger compartment air thermistor
- 8031 - Coolant thermistor
- 8045 - Blower control module (if separate)
- 8050 - Blower motor (if separate)
- 8065 - Mixing flap reduction motor
- 8070 - Air input flap reduction motor
- 8071 - Distribution flap reduction motor
- 8220 - Analogue module transponder
- 8410 - Radio
- 8413 - Radio control
- 8415 - Compact disc changer
- 8420 - Loud speakers on front door (driver's side)
- 8425 - Loud speakers on front door (passenger's side)
- 8430 - Loud speaker (rear left hand)
- 8435 - Loud speaker (rear right hand)
- 8440 - Front left hand tweeter speaker
- 8445 - Front right hand tweeter speaker
- 8500 - Navigation ECU

MULTIPLEXED BSI - XSARA PICASSO AND XSARA – PART 10